



**MOTOROLA**  
intelligence everywhere™



## ***PRO2150™ Portable Radio***

### ***Detailed Service Manual***



---

**User Safety, Training, and General Information.....v**
**Chapter 1 Introduction ..... 1-1**

1.1	Scope of Manual.....	1-1
1.2	Warranty and Service Support.....	1-1
1.2.1	Warranty Period and Return Instructions.....	1-1
1.2.2	After Warranty Period.....	1-1
1.2.3	Piece Parts.....	1-2
1.2.4	Technical Support.....	1-2
1.2.5	Parts Identification.....	1-2
1.3	Radio Model Information.....	1-3
1.4	Radio Features.....	1-4

**Chapter 2 Maintenance ..... 2-1**

2.1	Introduction.....	2-1
2.2	Preventive Maintenance.....	2-1
2.2.1	Inspection.....	2-1
2.2.2	Cleaning Procedures.....	2-1
2.3	Safe Handling of CMOS and LDMOS Devices.....	2-2
2.4	Repair Procedures and Techniques — General.....	2-2
2.4.1	Parts Replacement and Substitution.....	2-2
2.4.2	Rigid Circuit Boards.....	2-2
2.4.3	Flexible Circuits.....	2-3
2.4.4	Chip Components.....	2-3
2.4.5	Shields.....	2-4
2.5	Disassembling and Reassembling the Radio — General.....	2-4
2.6	Radio Disassembly — Detailed.....	2-5
2.6.1	Front Cover from Chassis Disassembly.....	2-5
2.6.2	Control Board Disassembly.....	2-7
2.6.3	RF Board Disassembly.....	2-7
2.7	Radio Reassembly — Detailed.....	2-8
2.7.1	RF Board Reassembly.....	2-8
2.7.2	Control Board Reassembly.....	2-8
2.7.3	Chassis and Front Cover Reassembly.....	2-8
2.8	Mechanical View and Parts List.....	2-12
2.8.1	Exploded View and Parts List.....	2-12
2.9	Service Aids.....	2-14
2.10	Test Equipment.....	2-15
2.11	Programming Cable (DSK001C706).....	2-16
2.12	IF Test Box (DSK001C702).....	2-17

---

<b>Chapter 3</b>	<b>Radio Tuning .....</b>	<b>3-1</b>
3.1	Introduction .....	3-1
3.2	Software Tuning Setup .....	3-1
3.3	Affixing Antenna Ground Plate.....	3-2
3.4	Hardware Tuning Setup and Procedure .....	3-3
3.4.1	Audio Modulation Tuning .....	3-3
3.4.2	Sub-Audio Modulation Tuning.....	3-4
3.4.3	Tuning Frequency .....	3-4
<b>Chapter 4</b>	<b>Radio Programming.....</b>	<b>4-1</b>
4.1	Introduction .....	4-1
4.2	Programming Your Radio .....	4-1
4.2.1	Overview of the Programming Process .....	4-1
4.2.2	Cloning Radio Parameters to User Radios .....	4-1
4.2.3	Parameters Which are Cloned .....	4-1
4.2.4	Parameters Which are Not Cloned .....	4-1
4.2.5	To Clone a Radio .....	4-1
4.2.6	Error Conditions .....	4-2
4.3	CPS Programming .....	4-2
4.4	Programming .....	4-3
4.4.1	PL Frequencies and Codes .....	4-3
4.4.2	DPL Codes.....	4-4
4.4.3	Examples .....	4-4
<b>Chapter 5</b>	<b>Error Code Displays.....</b>	<b>5-1</b>
5.1	Error Codes.....	5-1
<b>Chapter 6</b>	<b>Accessories .....</b>	<b>6-1</b>
6.1	Antennas.....	6-1
6.2	Carrying Accessories .....	6-1
6.3	Carry Cases .....	6-1
6.4	Chargers .....	6-1
6.5	Batteries.....	6-1
6.6	Audio Accessories .....	6-1
6.7	Manuals .....	6-2
6.8	Software.....	6-2

---

**Chapter 7 VHF Band Information ..... 7-1**

7.1	Model Chart .....	7-1
7.2	Specifications.....	7-2
7.3	Theory of Operation.....	7-3
7.3.1	General Information .....	7-3
7.3.2	Power Distribution.....	7-3
7.3.3	Power up Sequence .....	7-3
7.3.4	CPU / Control Section.....	7-4
7.3.5	VCO / Synthesizer Section .....	7-4
7.3.6	Transmitter Section.....	7-5
7.3.7	Receiver Section.....	7-6
7.3.8	Battery Section .....	7-7
7.4	Block Diagrams.....	7-8
7.4.1	Complete .....	7-8
7.4.2	Controller .....	7-9
7.4.3	VCO .....	7-9
7.4.4	Transmitter.....	7-10
7.4.5	Receiver.....	7-10
7.5	Troubleshooting Charts .....	7-11

**Chapter 8 UHF Band Information ..... 8-1**

8.1	Model Charts .....	8-1
8.2	Specifications.....	8-3
8.3	Theory of Operation.....	8-4
8.3.1	General Information .....	8-4
8.3.2	Power Distribution.....	8-4
8.3.3	Power up Sequence .....	8-4
8.3.4	CPU / Control Section.....	8-5
8.3.5	VCO / Synthesizer Section .....	8-5
8.3.6	Transmitter Section.....	8-6
8.3.7	Receiver Section.....	8-7
8.3.8	Battery Section .....	8-8
8.4	Block Diagrams.....	8-9
8.4.1	Complete .....	8-9
8.4.2	Controller .....	8-10
8.4.3	VCO .....	8-10
8.4.4	Transmitter.....	8-11
8.4.5	Receiver.....	8-11
8.5	Troubleshooting Charts .....	8-12

**This Page Intentionally Left Blank**

---

# User Safety, Training, and General Information

## Product Safety and RF Exposure Compliance



**CAUTION:** Before using this product, read the operating instructions for safe usage contained in the Product Safety and RF Exposure booklet enclosed with your radio.

### **ATTENTION!**

This radio is restricted to occupational use only to satisfy FCC RF energy exposure requirements. Before using this product, read the RF energy awareness information and operating instructions in the Product Safety and RF Exposure booklet enclosed with your radio (Motorola Publication part number 68P81095C98) to ensure compliance with RF energy exposure limits.

For a list of Motorola-approved antennas, batteries, and other accessories, visit the following web site which lists approved accessories: <http://www.motorola.com/cgiss/index.shtml>.

**This Page Intentionally Left Blank**



---

# Chapter 1 Introduction

## 1.1 Scope of Manual

This manual is intended for use by service technicians familiar with similar types of equipment. It contains service information required for the equipment described and is current as of the printing date. Changes which occur after the printing date may be incorporated by a complete Manual revision or alternatively as additions.

**NOTE:** Before operating or testing these units, please read the User Safety, Training and General Information Section in the front of this manual.

## 1.2 Warranty and Service Support

Motorola offers long term support for its products. This support includes repair of the product during the warranty period, and service/repair or spare parts support out of warranty.

### **Motorola de Colombia Service Center**

Carrera 7 No. 71-52

Torre B, Piso 13

Oficina 1301

Bogota - Colombia

Phone: 571-376-6990

### **Motorola de Mexico Service Center**

Bosques de Alisos #125

Col. Bosques de las Lomas

CP 05120 Mexico D.F.

Phone: 525-257-6700

### 1.2.1 Warranty Period and Return Instructions

Where the product is covered under warranty, a check of the product should be performed prior to shipping the unit. This is to ensure that the product has been correctly programmed or has not been subjected to damage outside the terms of the warranty.

Products should be shipped back in the original packaging, or correctly packaged to ensure no damage occurs in transit.

### 1.2.2 After Warranty Period

After the Warranty period, Motorola continues to support its products in two ways.

1. Motorola's authorized service centers offer a repair service to both end users and dealers at competitive prices.
  2. AAD supplies individual parts and modules that can be purchased by dealers who are technically capable of performing fault analysis and repair.
-

### 1.2.3 Piece Parts

Some replacement parts, spare parts, and/or product information can be ordered directly. If a complete Motorola part number is assigned to the part, it is available from Motorola's Accessories and Aftermarket Division (AAD). If no part number is assigned, the part is not normally available from Motorola. If the part number is appended with an asterisk, the part is serviceable by Motorola Depot only. If a parts list is not included, this generally means that no user-serviceable parts are available for that kit or assembly.

All orders for parts/information should include the complete Motorola identification number. All part orders should be directed to your local AAD office. Please refer to your latest price pages.

To order parts in Latin America and the Caribbean:

7:00 a.m. to 7:00 p.m. (Central Standard Time)

Monday through Friday (Chicago, USA)

1-847-538-8023

Motorola Parts (Accessories and Aftermarket Division AAD):

Attention: Order Processing

1313 E. Algonquin Road

Schaumburg, IL 60196

### 1.2.4 Technical Support

<https://businessonline.motorola.com>

Select: "Contact Us"

### 1.2.5 Parts Identification

1-847-538-0021 (Voice)

1-847-538-8194 (Fax)

### 1.3 Radio Model Information

The model number and serial number are located on a label attached to the back of your radio. You can determine the RF output power, frequency band, protocols, and physical packages. The example below shows one portable radio model number and its specific characteristics.

Table 1-1. Radio Model Number (Example: LAH49KDH8AA9)

	Type of Unit	Model Series	Frequency Band	Power Level	Physical Packages	Channel Spacing	Protocol	Feature Level
LA	H	49	K (136-174 MHz)	D 5W	H Full Keypad with Display	8 12.5/25K	AA Conventional	9 Full Keypad
			Q (403-440 MHz)	C 4W				
			R (435-480 MHz)					

H = Portable  
 Motorola Internal Use

## 1.4 Radio Features

Feature	PRO2150	
	CPS	User
<b>Accessibility</b>	<b>Yes</b>	Yes
<b>Normal Operation</b>		
Rx/Tx	X	X
Cloning	X	X
Factory Reset	X	
VFO	X	
Squelch Level	X	X
Scan List 1	X	X
Scan List 2	X	X
Scan List 3	X	X
Special PL 1,2,3	X	
Norm/Inv DPL	X	
TOT	X	X
Battery Saver	X	X
Battery Type	X	X
Alert Tone Volume	X	X
Prime Ch	X	X
Prime Ch Return Hang Time	X	
PTT ID (OFF, PRE, POST, BOTH)	X	
PTT ID Sidetone	X	
PTT Short Sidetone	X	
Tx Pretime	X	
Backlight Status	X	X
PTT ID	X	
Button Programmability	X	
Access/Deaccess Code	X	X
Telephone No	X	X
PL/DPL Type	X	
Scan Interval Timer	X	
Scan Hang Timer	X	
Channel On/Off	X	
Rx Freq	X	
Tx Freq	X	
Rx PL/DPL	X	

Feature	PRO2150	
	CPS	User
Tx PL/DPL	X	
TOC	X	
Power Level	X	
BCL	X	
Ch Alias	X	
Ch Spacing	X	
PTT ID On/Off	X	
PL Required for Selcall	X	
Scan Type Select	X	
Scan List Select	X	
Copy Ch	X	
Scan Lower Limit	X	
Scan Upper Limit	X	
Freq Step Size	X	
Rx Freq	X	
Tx Freq	X	
Offset Freq	X	
Repeater Offset	X	
Rx PL/DPL	X	
Tx PL/DPL	X	
TOC	X	
Power Level	X	
BCL	X	
Ch Spacing	X	
PTT ID On/Off	X	
Radio Information	X	X
Radio Configuration	X	X
Conventional Personality	X	X
VFO Status	X	
Scan List	X	X
Phone Information	X	X
Signalling	X	X
Programmable Button	X	X
Reverse Burst	X	

X = Indicates available

Blank = Indicates unavailable

**This Page Intentionally Left Blank**

---

# Chapter 2 Maintenance

## 2.1 Introduction

This chapter provides details about the following:

- Preventive Maintenance
- Safe Handling of CMOS and LDMOS Devices
- General Repair Procedures and Techniques
- Disassembling and Reassembling the Radio

## 2.2 Preventive Maintenance

The radio does not require a scheduled preventive maintenance program; however, periodic visual inspection and cleaning is recommended.

### 2.2.1 Inspection

Check that the external surfaces of the radio are clean, and that all external controls and switches are functional. It is not recommended to inspect the interior electronic circuitry.

### 2.2.2 Cleaning Procedures

The following procedures describe the recommended cleaning agents and the methods to be used when cleaning the external and internal surfaces of the radio. External surfaces include the front cover, housing assembly and battery case. These surfaces should be cleaned whenever a periodic visual inspection reveals the presence of smudges, grease, and/or grime.

**NOTE:** Internal surfaces should be cleaned only when the radio is disassembled for service or repair.

The only recommended agent for cleaning external radio surfaces is a 0.5% solution of a mild dishwashing detergent in water. The only factory recommended liquid for cleaning printed circuit boards and their components is isopropyl alcohol (70% by volume).



**CAUTION:** The effects of certain chemicals and their vapors can have harmful results on certain plastics. Avoid using aerosol sprays, tuner cleaners, and other chemicals.

#### 2.2.2.1 Cleaning External Plastic Surfaces

Apply the 0.5% detergent-water solution sparingly with a stiff, non-metallic, short-bristled brush to work all loose dirt away from the radio. Use a soft, absorbent, lintless cloth or tissue to remove the solution and dry the radio. Make sure that no water remains entrapped near the connectors, cracks, or crevices.

#### 2.2.2.2 Cleaning Internal Circuit Boards and Components

Apply Isopropyl alcohol (70%) with a stiff, non-metallic, short-bristled brush to dislodge embedded or caked materials located in hard-to-reach areas. The brush stroke should direct the dislodged material out and away from the inside of the radio. Make sure that controls or tunable components are not soaked with alcohol. Do not use high-pressure air to hasten the drying process since this could cause the liquid to collect in unwanted places. After completing the cleaning process, use a soft, absorbent, lintless cloth to dry the area. Do not brush or apply any isopropyl alcohol to the frame, front cover, or back cover.

---

**NOTE:** Always use a fresh supply of alcohol and a clean container to prevent contamination by dissolved material (from previous usage).

## 2.3 Safe Handling of CMOS and LDMOS Devices

Complementary metal-oxide semiconductor (CMOS) devices are used in this family of radios, and are susceptible to damage by electrostatic or high voltage charges. Damage can be latent, resulting in failures occurring weeks or months later. Therefore, special precautions must be taken to prevent device damage during disassembly, troubleshooting, and repair.

Handling precautions are mandatory for CMOS circuits and are especially important in low humidity conditions. DO NOT attempt to disassemble the radio without first referring to the following CAUTION statement.



**CAUTION:** This radio contains static-sensitive devices. Do not open the radio unless you are properly grounded. Take the following precautions when working on this unit:

- Store and transport all CMOS devices in conductive material so that all exposed leads are shorted together. Do not insert CMOS devices into conventional plastic “snow” trays used for storage and transportation of other semiconductor devices.
- Ground the working surface of the service bench to protect the CMOS device. We recommend using the Motorola Static Protection Assembly (part number 0180386A82), which includes a wrist strap, two ground cords, a table mat, and a floor mat.
- Wear a conductive wrist strap in series with a 100k resistor to ground. (Replacement wrist straps that connect to the bench top covering are Motorola part number RSX-4015.)
- Do not wear nylon clothing while handling CMOS devices.
- Do not insert or remove CMOS devices with power applied. Check all power supplies used for testing CMOS devices to be certain that there are no voltage transients present.
- When straightening CMOS pins, provide ground straps for the apparatus used.
- When soldering, use a grounded soldering iron.
- If at all possible, handle CMOS devices by the package and not by the leads. Prior to touching the unit, touch an electrical ground to remove any static charge that you may have accumulated. The package and substrate may be electrically common. If so, the reaction of a discharge to the case would cause the same damage as touching the leads.

## 2.4 Repair Procedures and Techniques — General

### 2.4.1 Parts Replacement and Substitution

When damaged parts are replaced, identical parts should be used. If the identical replacement part is not locally available, check the parts list for the proper Motorola part number and order the part from the nearest Motorola Communications parts center listed in the Piece Parts section of this manual.

### 2.4.2 Rigid Circuit Boards

This radio uses bonded, multi-layer, printed circuit boards. Since the inner layers are not accessible, some special considerations are required when soldering and unsoldering components. The printed-through holes may interconnect multiple layers of the printed circuit. Therefore, exercise care to avoid pulling the plated circuit out of the hole.



When soldering near the 20-pin and 40-pin connectors:

- Avoid accidentally getting solder in the connector.
- Be careful not to form solder bridges between the connector pins.
- Examine your work closely for shorts due to solder bridges.

### 2.4.3 Flexible Circuits

The flexible circuits are made from a different material than the rigid boards, and require different soldering techniques. Excessive prolonged heat on a flexible circuit can damage the material. Therefore, avoid excessive heat and excessive bending.

For parts replacement, use the ST-1087 Temperature-Controlled Solder Station with a 600-700 degree F tip, and use small diameter solder such as ST-633. The smaller size solder will melt faster and require less heat to be applied to the circuit.

To replace a component on a flexible circuit:

1. Grasp with seizers (hemostats) the edge of the flexible circuit near the part to be removed.
2. Pull gently.
3. Apply the tip of the soldering iron to the component connections while pulling with the seizers.

**NOTE:** Do not attempt to puddle-out components. Prolonged application of heat may damage the flexible circuit.

### 2.4.4 Chip Components

Use either the RLN-4062 Hot-Air Repair Station or the Motorola 0180381B45 Repair Station for chip component replacement. When using the 0180381B45 Repair Station, select the TJ-65 mini-thermojet hand piece. On either unit, adjust the temperature control to 700 degrees F. (370 degrees C), and adjust the airflow to a minimum setting. Airflow can vary due to component density.

- To remove a chip component, select a hot-air hand piece and position the nozzle of the hand piece approximately 1/8" above the component to be removed. Begin applying hot air. Once the solder reflows, remove the component using a pair of tweezers. Using solder wick and a soldering iron or a power desoldering station, remove the excess solder from the pads.
- To replace a chip component using a soldering iron, select the appropriate micro-tipped soldering iron and apply fresh solder to one of the solder pads. Using a pair of tweezers, position the new chip component in place while heating the fresh solder. Once solder wicks onto the new component, remove the heat from the solder. Heat the remaining pad with the soldering iron and apply solder until it wicks to the component. If necessary, touch up the first side. All solder joints should be smooth and shiny.
- To replace a chip component using hot air, select the hot-air hand piece and reflow the solder on the solder pads to smooth it. Apply a drop of solder paste flux to each pad. using a pair of tweezers, position the new component in place. Position the hot-air hand piece approximately 1/8" above the component and begin applying heat. Once the solder wicks to the component, remove the heat and inspect the repair. All joints should be smooth and shiny.

### 2.4.5 Shields

Removing and replacing shields will be done with the R-1070 station with the temperature control set to approximately 415°F (215°C); 445°F (230°C) max.

- To remove the shield, place the circuit board in the R-1070's holder. Select the proper heat focus head and attach it to the heater chimney. Add solder paste flux around the base of the shield. Position the shield under the heat-focus head. Lower the vacuum tip and attach it to the shield by turning on the vacuum pump. Lower the focus head until it is approximately 1/8" (0.3cm) above the shield. Turn on the heater and wait until the shield lifts off the circuit board. Once the shield is off, turn off the heat, grab the part with a pair of tweezers, and turn off the vacuum pump. Remove the circuit board from the R-1070's circuit board holder.
- To replace the shield, add solder to the shield if necessary, using a micro-tipped soldering iron. Next, rub the soldering iron tip along the edge of the shield to smooth out any excess solder. Use solder wick and a soldering iron to remove excess solder from the solder pads on the circuit board. Place the circuit board back in the R1070's circuit board holder. Place the shield on the circuit board using a pair of tweezers. Position the heat-focus head over the shield and lower it to approximately 1/8" above the shield. Turn on the heater and wait for the solder to reflow.  
Once complete, turn off the heat, raise the heat-focus head and wait approximately one minute for the part to cool. Remove the circuit board and inspect the repair. No cleaning should be necessary.

## 2.5 Disassembling and Reassembling the Radio — General

Since these radios may be disassembled and reassembled with the use of only four (board to casting) screws, it is important to pay particular attention to the snaps and tabs, and how parts align with each other.

The following tools are required for disassembling the radio:

- Phillips screwdriver
- 4mm socket wrench

If a unit requires more complete testing or service than is customarily performed at the basic level, send this unit to a Motorola Authorized Service Center.

## 2.6 Radio Disassembly — Detailed

### 2.6.1 Front Cover from Chassis Disassembly

1. Turn off the radio.
2. Remove the battery:
  - a. Slide the battery clasp away from the radio (See Figure 2-1.).



Figure 2-1.

- b. Slide battery down and away from radio.
3. Remove the antenna.
4. Pull the On/Off Volume knob off of its shaft.
5. Remove the two screws at the back of the rear chassis (See Figure 2-2.).

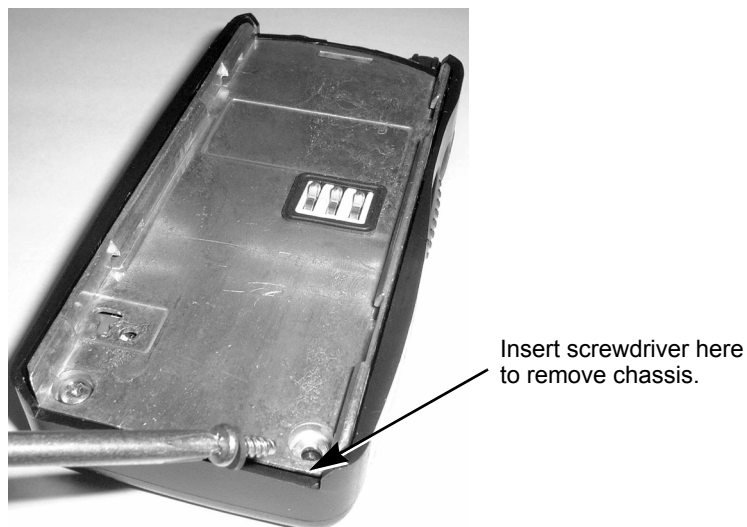

Figure 2-2.

6. Insert a small flat-head screwdriver at the bottom of the radio, between the chassis and housing (location marked in Figure 2-2), and lift the chassis gently. Be careful not to damage the housing or the O-ring underneath.

7. Lift the rear chassis away from the front cover (See Figure 2-3.). Be careful not to damage the speaker wire underneath.

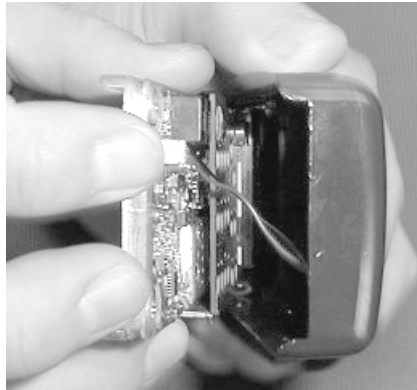

Figure 2-3.

8. Slide the rear chassis downwards, and away from the front cover.
9. Remove the speaker connector, which connects between RF Board and the internal speaker on the front cover (See Figure 2-4.).

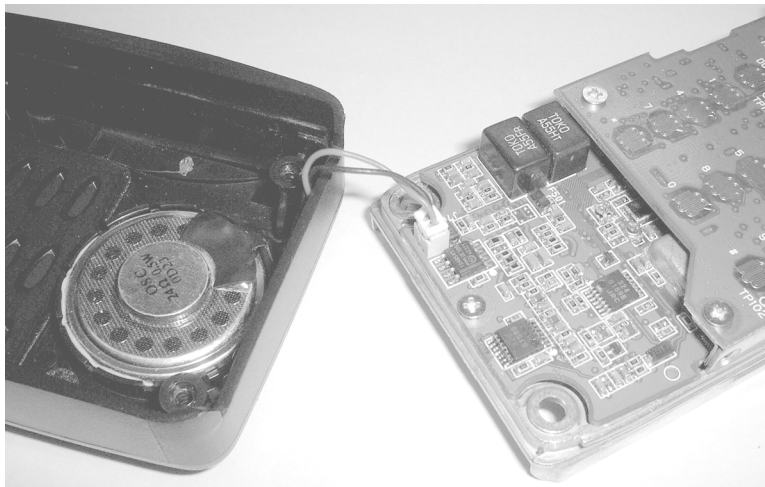

Figure 2-4.

## 2.6.2 Control Board Disassembly

1. Remove the screws which hold the control board to the RF board.
2. Remove the control board which is connected to the RF board through a board-to-board connector (See Figure 2-5.).



Figure 2-5.

## 2.6.3 RF Board Disassembly

1. Remove the screws and the stud which hold the RF board to the rear diecast with the Phillips head screwdriver and socket wrench respectively.
2. Gently remove the RF board from rear diecast. The completely disassembled radio is shown in Figure 2-6.

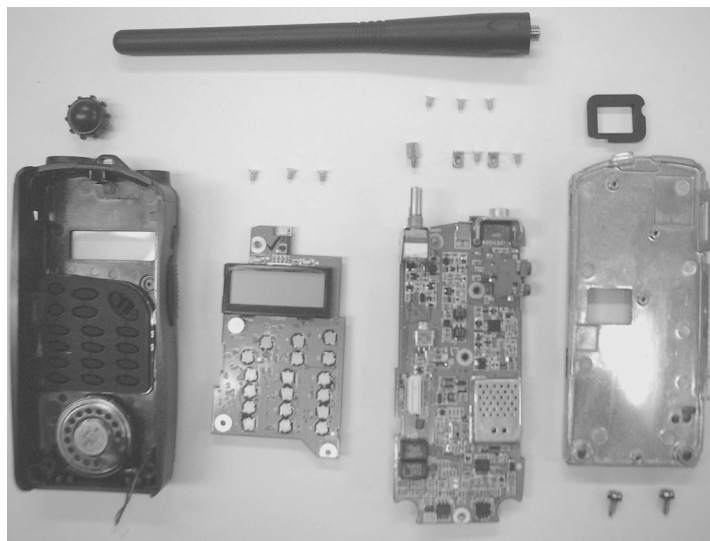

Figure 2-6.

**NOTE:** The Control and RF boards are mounted with cross recess screws meeting the Phillips Cross Slot number 1 standard. Using a Phillips 0 will damage the screw recesses as will a poorly fitting Phillips 1 screwdriver. One example of a correct fitting screwdriver is manufactured by PB Baumann ([http://www.pbtools.ch/index\\_e.html](http://www.pbtools.ch/index_e.html)) and is available from many electronic tool dealers. The PB Baumann item number is 121/1-70. Other high quality manufacturer's products meeting the Phillips 1 standard are also acceptable.

## 2.7 Radio Reassembly — Detailed

### 2.7.1 RF Board Reassembly

1. Place the RF board on the rear diecast.
2. Tighten the screws and the stud.

### 2.7.2 Control Board Reassembly

1. Place the control board on the RF board.
2. Connect the control board to the RF board by pressing it firmly downwards at the board-to-board connector (See [Figure 2-7](#)).

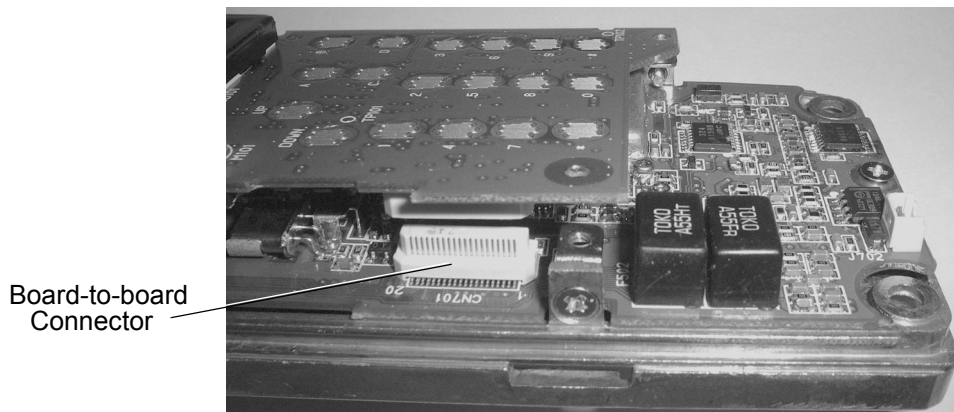

Figure 2-7.

3. Tighten the screws using a screwdriver to hold the control board in place.

### 2.7.3 Chassis and Front Cover Reassembly

1. Remove the metal retainer with a small flat head screwdriver (See [Figure 2-11](#)).

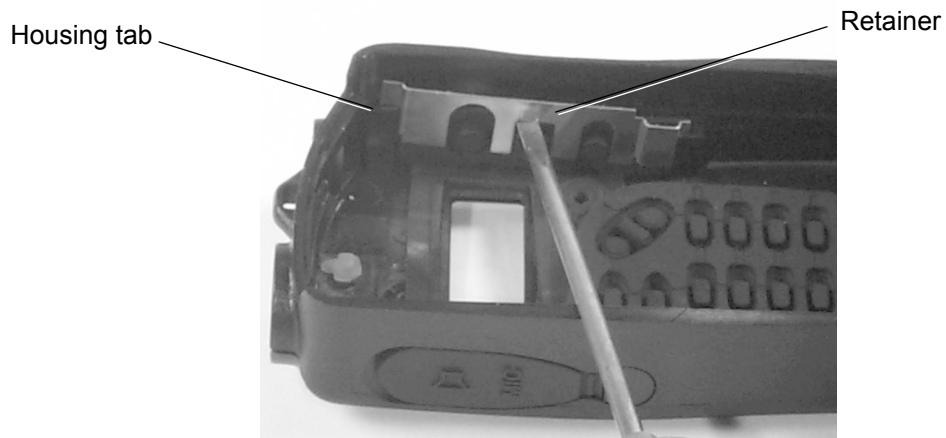

Figure 2-8.

2. Remove the rubber button insert behind the retainer (See Figure 2-9.).

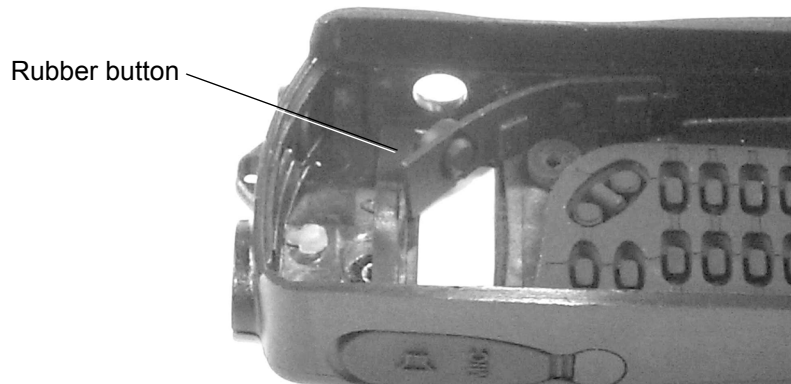

Figure 2-9.

3. Push left hand side PTT hook until it releases (See Figure 2-10.).

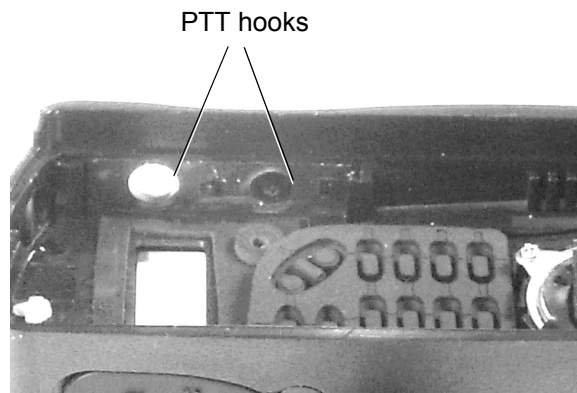

Figure 2-10.

4. Push right hand side PTT hook until PTT button is completely released.
5. Reinstall the rubber insert and metal retainer.
6. Connect the RF board to the internal speaker on the front cover with the speaker connector (See Figure 2-11.).

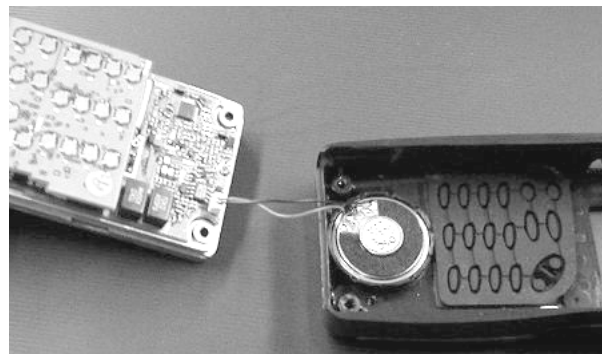
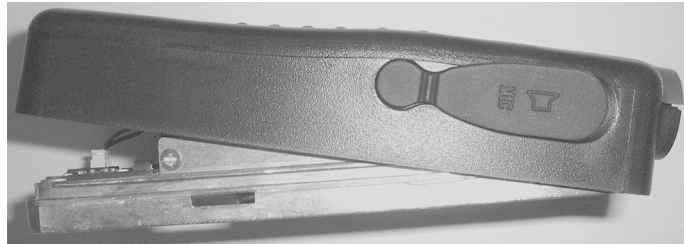

Figure 2-11.

7. Place the front cover over the tabs on the rear diecast.
8. Insert the On/Off Volume shaft into the front cover opening.
9. Lower the front cover until the bottom edges snap firmly into place on the rear diecast (See [Figure 2-12.](#)).



*Figure 2-12.*

10. Tighten the two (2) screws at the bottom of rear diecast using a screwdriver (See [Figure 2-13.](#)).



*Figure 2-13.*

11. Reinsert the PTT button (See [Figure 2-15.](#)).

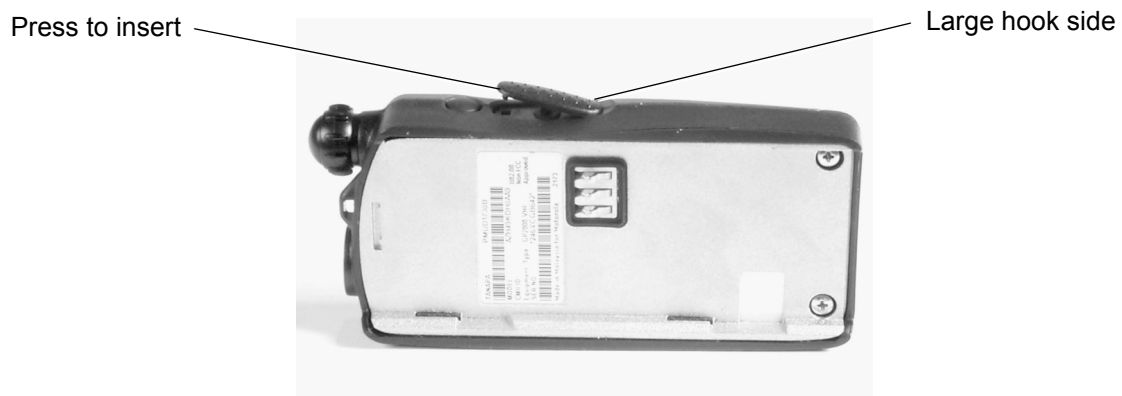

*Figure 2-14.*



12. Attach the battery.
13. Attach the On/Off Volume knob and the antenna.



*Figure 2-15.*

## 2.8 Mechanical View and Parts List

### 2.8.1 Exploded View and Parts List

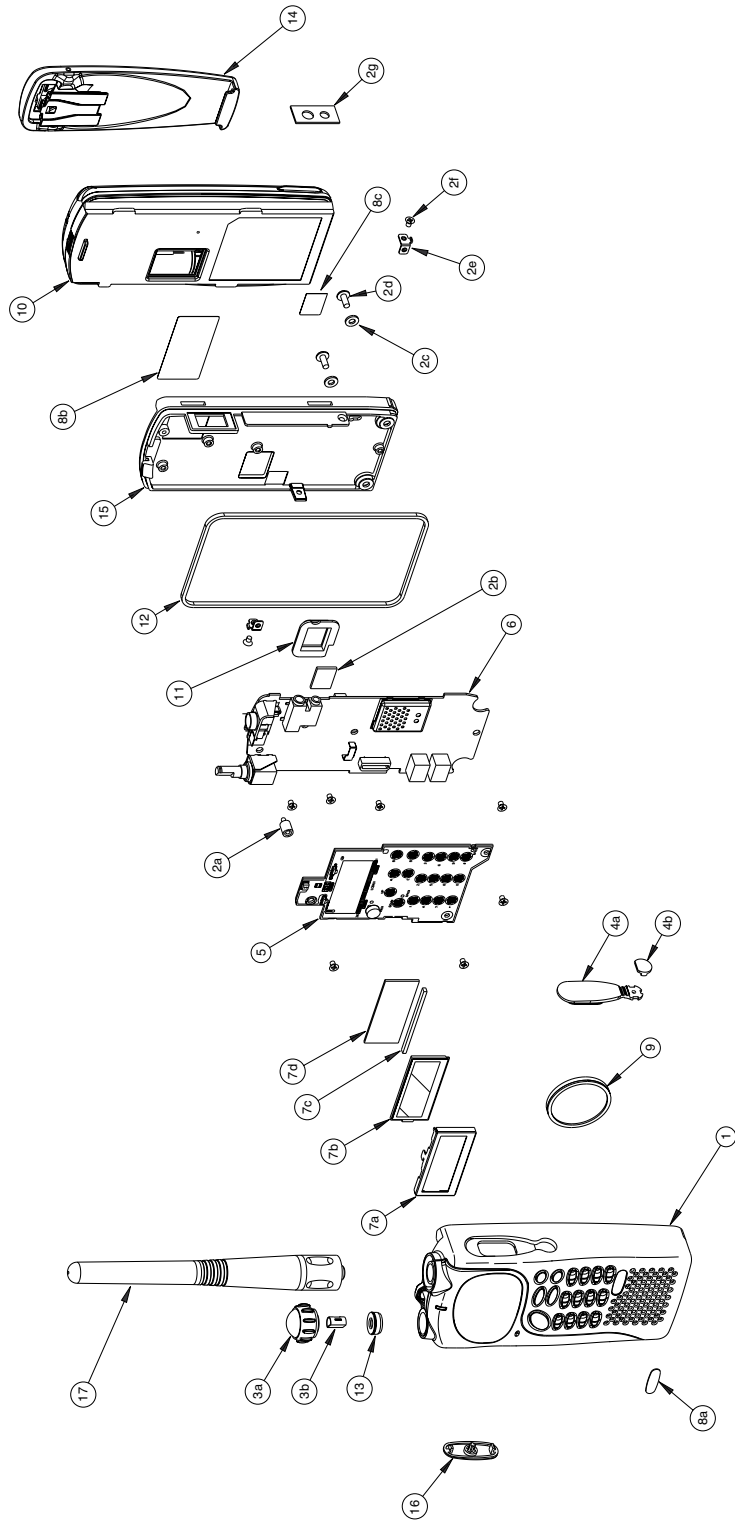

Figure 2-16.

Item	Part Number	Description
1	DS1M001110	Front Cover Kit
2	DS1M001120	Chassis Hardware Kit
2a		Rod (M2)
2b		Heatsink Tape
2c	DSM4193013	Gasket (Screw M2.6)
2d	DSM1B26051	Screw M2.6
2e		PCB Bracket
2f		Screw M2 Cfims
2g		External Tape
3	DS1M001130	Knob Assembly
3a		Knob
3b		Spring (D4.75)
4	DS1M001140	External Cover Kit
4a		External Cover
4b		External Cover Cap
5	Model Dependent	Controller Board Assembly
6	Model Dependent	RF Board Assembly
7	DS1M001170	LCD Kit
7a		LCD Bracket
7b		LCD
7c		Interconnector
7d		Reflector
8	DSM4193042	PRO2150 Nameplate
8a		Label Nameplate
8b		Label Serial
8c		Label Tuning
9	DS1M001190	Speaker Assembly
10	PMNN4046	Battery
11	DSM2192004	Contact Gasket
12	DSM2192005	Main Gasket
13	DSM2192006	Volume Gasket
14	HLN9844_	Beltclip

Item	Part Number	Description
15	DSM5190001	Back Housing
16	DSM6189003	PTT Button
17	Frequency dependent. Please see <a href="#">“6.1 Antennas” on page 6-1</a>	Antenna

## 2.9 Service Aids

[Table 2-1](#) lists service aids recommended for working on the PRO2150 Portable Radio. While all these items are available from Motorola, most are standard shop equipment items, and any equivalent item capable of the same performance may be substituted for the item listed.

*Table 2-1.*

Motorola Part No.	Description	Application
H5197 HKVN4002_	Customer Programming and Tuning Software (CD)	Program customer options, channel data, and tuner hardware parameters, front end, power, etc.
DSK001C706	Programming Cable (2.5mm)	Connects radio and IF Test Box to Computer.
AAPMKN4003_	Cloning Cable (2.5mm)	To clone programmable information from one radio to another radio.
DSK001C704	Test Cable	Connects radio to IF Test Box.
DSK001C714	Interconnect Service Cable	Connects RF board and CPU board.
DSK001C702	IF Test Box	Enables connection to the audio/accessory jack. Allows switching for radio testing.
DSK001C705	Battery Eliminator	Interconnects radio to power supply (red-and-black power cable included).
DSK001C719	Antenna Ground Plate	To improve the grounding while tuning and doing conducted measurement.
HLN8262_	BNC Adaptor	Adapts radio's antenna port to BNC cabling of test equipment.

## 2.10 Test Equipment

Table 2-2 lists test equipment required to service the PRO2150 Portable Radio and other two-way radios.

Table 2-2.

Motorola Part No.	Description	Characteristics	Application
*R1049	Digital Multimeter		Two meters recommended for AC/DC voltage and current measurements
*S1100	Audio Oscillator	67 to 200Hz tones	Used with service monitor to inject PL tones
*S1053, *SKN6009, *SKN6001	AC Voltmeter, Power Cable for meter, Test leads for meter	1 mV to 300 V, 10 Mega Ohm input impedance	Audio voltage measurements
R1053	Dual-trace Oscilloscope	20 MHz bandwidth, 5 mV/cm - 20 V/cm	Waveform measurements
*S1350, *ST1215 (VHF) *ST1223 (UHF) *T1013	Wattmeter, Plug-in Elements (VHF & UHF), RF Dummy Load	50-Ohm, $\pm 5\%$ accuracy 10 W, max. 0-1000 MHz, 300 W	Transmitter power output measurements
S1339	RF Millivolt Meter	100 $\mu$ V to 3 VRF, 10 kHz to 1.2 GHz	RF level measurements
*R1013	SINAD Meter		Receiver sensitivity measurements
S1347 or S1348 (prog)	DC Power Supply	0-20 Vdc, 0-5 Amps	Bench supply for 7.5Vdc

\*Frequency/deviation meter and signal generator for wide-range troubleshooting and alignment

## 2.11 Programming Cable (DSK001C706)

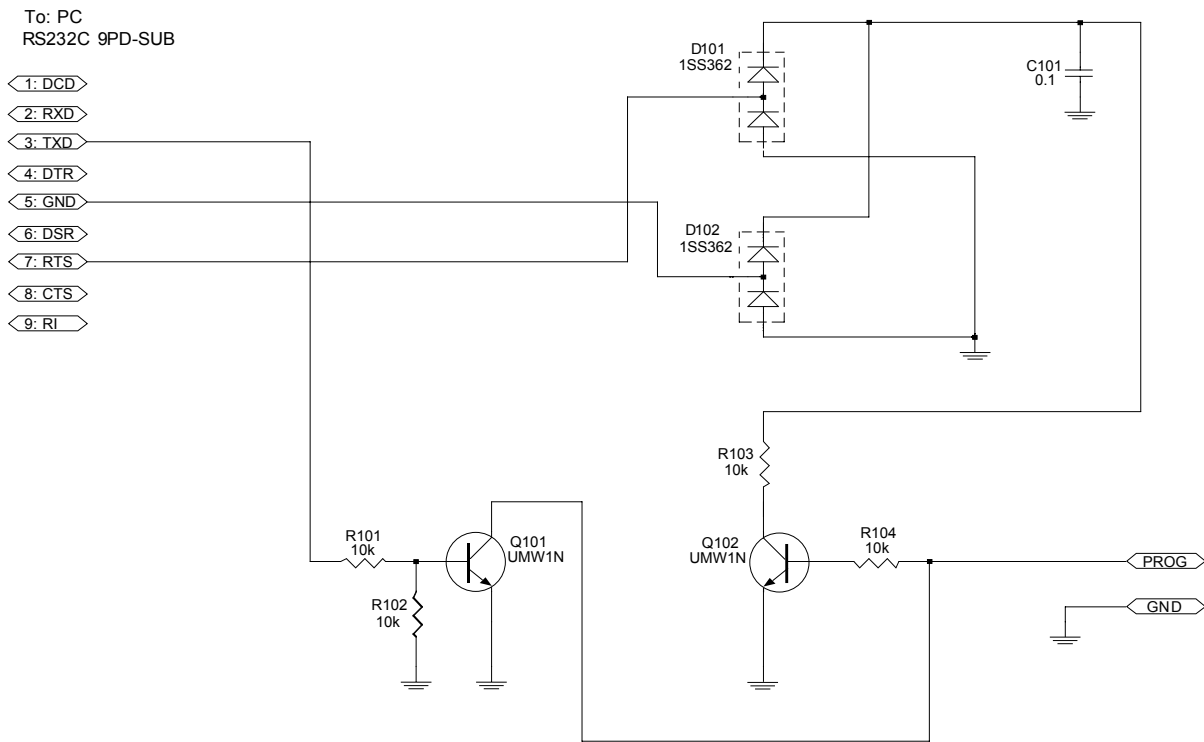

Figure 2-17.

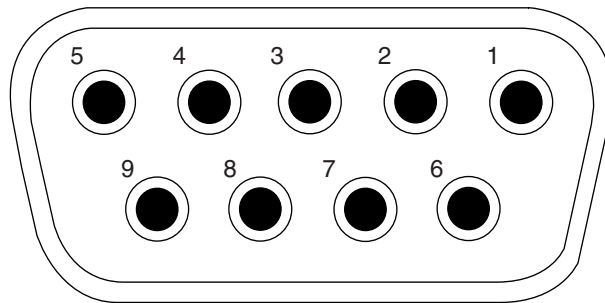

Figure 2-18.

## 2.12 IF Test Box (DSK001C702)

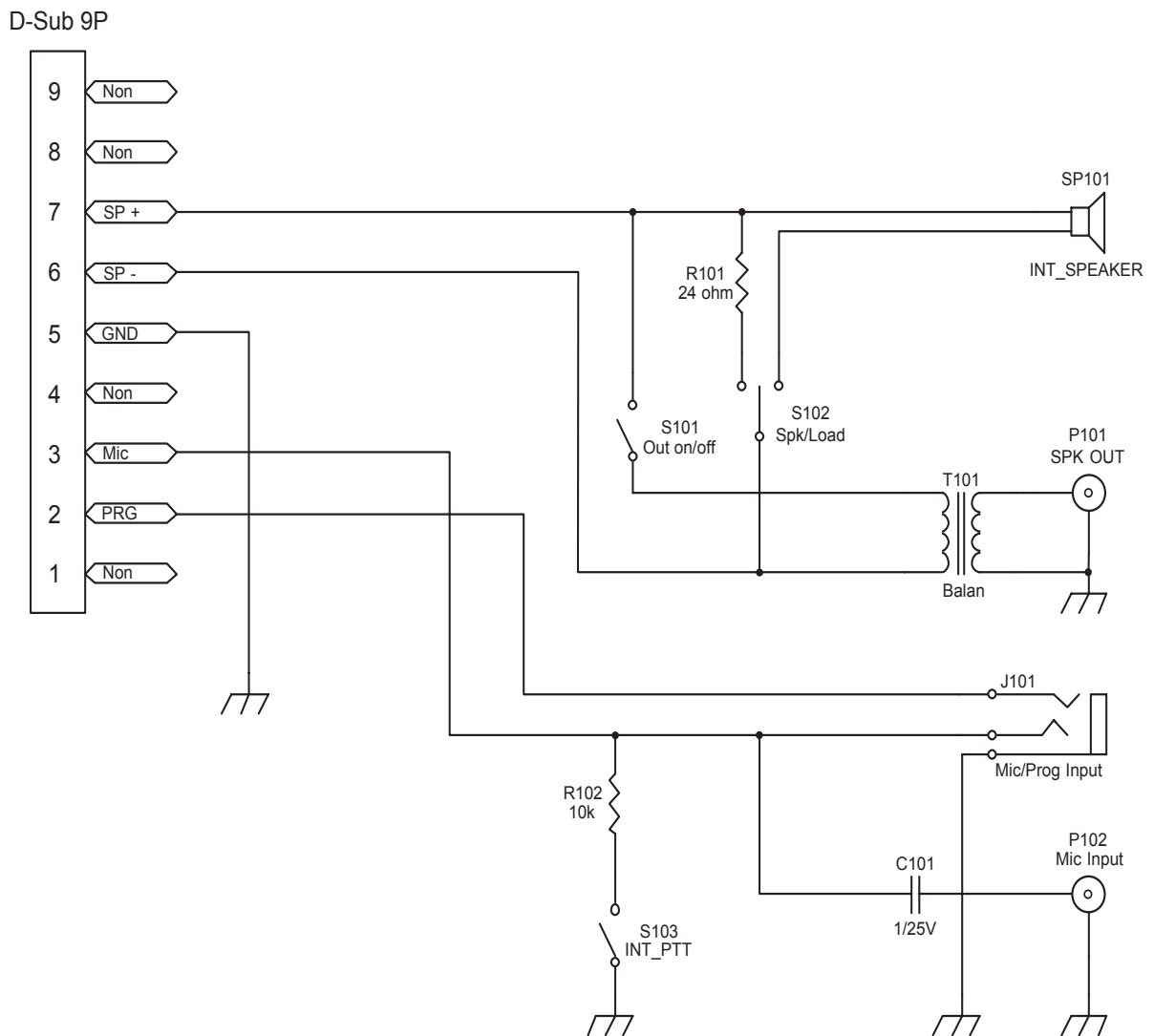

Figure 2-19.

**This Page Intentionally Left Blank**



---

# Chapter 3 Radio Tuning

## 3.1 Introduction

This chapter provides an overview of the software and hardware tuning material available for the PRO2150 Portable Radio.

The PRO2150 Portable Radio's Customer Programming and Tuner Software are designed for use in a Windows 95/98/NT environment. This software covers all the functions of the traditional Radio Service Software (RSS) package.

An Installation instruction manual is contained within each kit.

Description	Kit Number
Customer Programming and Tuning Software (CD)	H5197 HKVN4002_

## 3.2 Software Tuning Setup

A Windows 95/98/NT PC (personal computer) and Tuner are required to tune parameters such as power, sensitivity, squelch and RSSI. To perform the tuning procedures, the radio must be connected to the PC and IF Test Set as shown in the figure below.

Refer to online help files for specific tuning procedures. See [Figure 3-2](#), how to attach the radio.

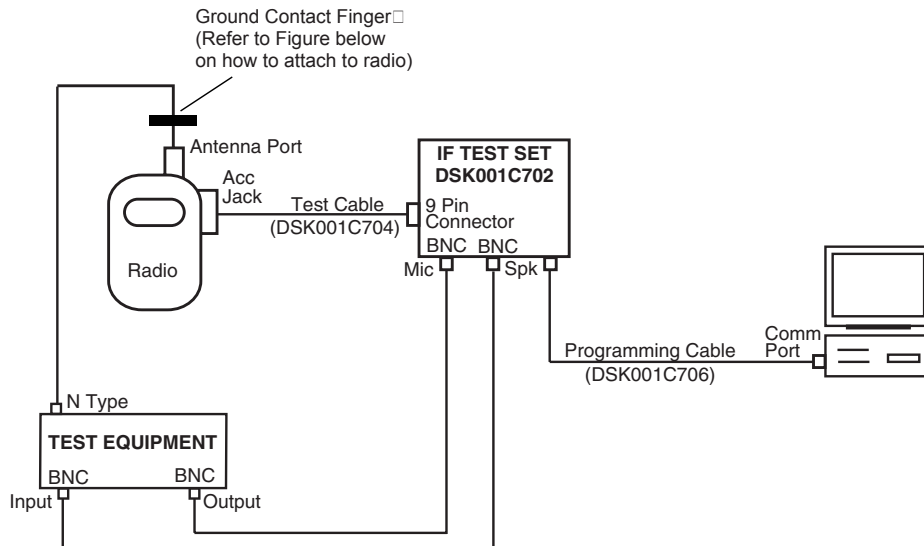

Figure 3-1.

---

### 3.3 Affixing Antenna Ground Plate

(Strictly for Radio's Testing and Tuning Purpose Only)

1. Insert the antenna ground plate (DSK001C719) through the antenna adaptor (HLN8262).

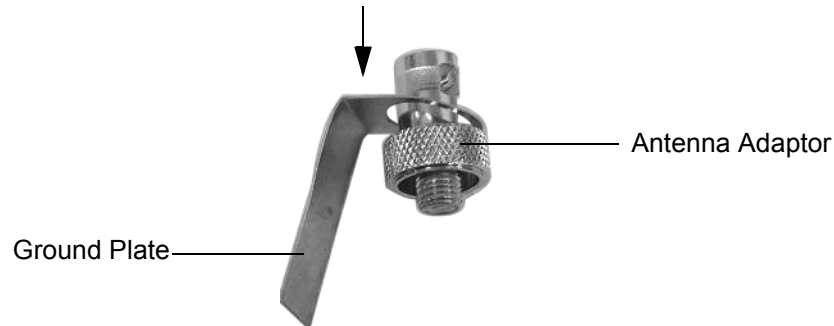

Figure 3-2.

2. Screw the antenna adaptor into the radio's antenna jack as shown in [Figure 3-3](#).

**NOTE:** Make sure the antenna ground plate is placed properly before the battery eliminator is inserted to the radio. This is to ensure that the radio has a better grounding.

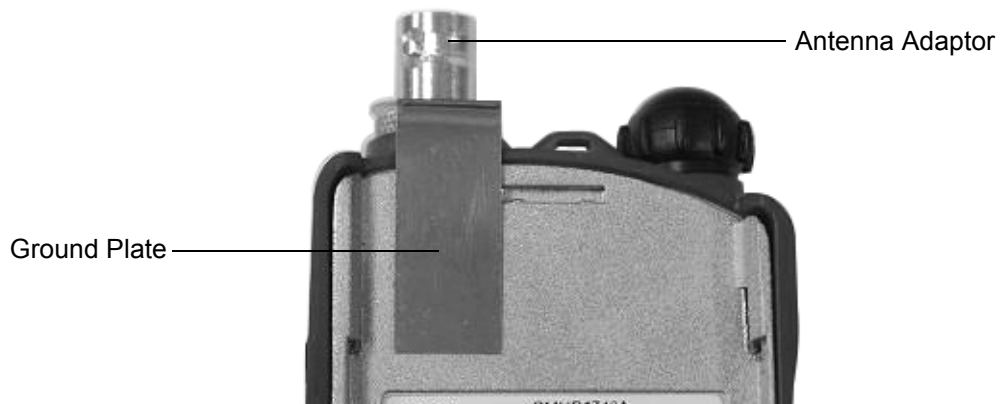

Figure 3-3.

## 3.4 Hardware Tuning Setup and Procedure

There is a silver seal on the bottom left of the radio chassis. Remove the seal to expose the two potentiometers for audio and sub-audio (CTCSS) modulation adjustment. RV601, which is slightly higher, is the trimmer potentiometer for audio modulation tuning. The lower trimmer potentiometer (RV602) is meant for sub-audio modulation tuning.

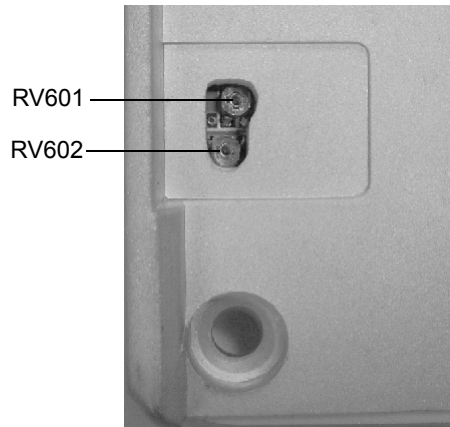

Figure 3-4.

### 3.4.1 Audio Modulation Tuning

1. Set the radio to transmit at the appropriate tuning frequency (See [“Tuning Frequency” in Table 3-1](#)) with low power. Set Channel Spacing to "CS-25.0" for 25kHz (see "Radio Programming" section).
2. On the test equipment, set it to receive at the appropriate tuning frequency (See [“Tuning Frequency” on page 3-4](#)) and with the following configurations:  
**Audio bandwidth:** 0.25Hz to 15,000Hz.  
**De-emphasis:** OFF
3. Inject a 60mV 1kHz tone to the radio through the external mic connector.
4. Key up the radio.
5. Using a ceramic tuning tool, adjust RV601 to tune the audio modulation deviation to settle between 4.3kHz to 4.5kHz.

### 3.4.2 Sub-Audio Modulation Tuning

1. Set the radio to transmit at the appropriate tuning frequency (See "Tuning Frequency" on table 3-1) with low power and TX PL frequency of 100.0Hz. Set Channel Spacing to "CS-25.0" for 25kHz (see "Radio Programming" section).
2. On the test equipment, set it to receive at the appropriate tuning frequency (see "PRO2150 Portable Radio Programming" section) and with the following configurations:

**Audio bandwidth:** 0.25Hz to 3,000Hz.

**De-emphasis:** OFF

3. Do **NOT** inject any tone to the radio.
4. Key up the radio.
5. Using a ceramic tuning tool, adjust RV602 to tune the sub-audio modulation deviation to settle between 0.65kHz to 0.75kHz.

### 3.4.3 Tuning Frequency

*Table 3-1.*

Band	Frequency (MHz)
VHF 136-174 MHz	155.025
UHF 403-440 MHz	421.5
UHF 435-480 MHz	457.5

---

# Chapter 4 Radio Programming

## 4.1 Introduction

The PRO2150 Portable Radio can be programmed by using the Customer Programming Software (CPS).

## 4.2 Programming Your Radio

### 4.2.1 Overview of the Programming Process

To prepare properly programmed radios for your customers, you should:

1. Program one radio with all the necessary parameters, as required by your customers.
2. Clone these parameters over to all your customer's radios.

### 4.2.2 Cloning Radio Parameters to User Radios

Cloning duplicates the contents of Radio 1 (master radio) into Radio 2 (slave radio). However, tuning and alignment information are not affected by cloning.

### 4.2.3 Parameters Which are Cloned

- Radio Wide parameters
- Channel settings
- VFO settings

### 4.2.4 Parameters Which are Not Cloned

- All hardware tuning and alignment parameters
- Unit Serial Number

### 4.2.5 To Clone a Radio

Cloning duplicates the contents of your radio (master radio) into your customer's radio (slave radio). Tuning and alignment information are not affected by cloning.

1. Turn off both the master and slave radios (if any of them are turned on).
  2. Connect both radios with the cloning cable through the Programming Port (lower port of the Accessory Connector).
  3. Turn on the slave radio.
  4. Press and hold the **A** button, and turn on the master radio.
  5. The master radio displays **CLONE** if cloning can proceed, otherwise an error message is shown.
  6. The slave radio displays **PROG** while it is being programmed.
  7. When cloning is completed, the master radio displays **END**, and the slave radio resets automatically.
  8. Disconnect radios from the cloning cable. They are now ready for operation.
-

### 4.2.6 Error Conditions

An error may occur when cloning a radio. When this happens, an error message is displayed. The following is a list of causes and the possible solutions for each error message.

Error Message	Description
TIME OUT	Data communications time-out. Please ensure that the slave radio is switched on, and the cloning cable is properly connected.
BCC ERR	Data communications checksum error.
TYPE ERR	Mismatch in model numbers. Please ensure that the master and slave radios are of the same model number.
CMD ERR	Data communications command error.

### 4.3 CPS Programming

The CPS is designed for use in the Windows 95/98/NT environment.

An Installation instruction manual is contained within each CPS kit.

Description	Kit Number
PRO2150 Customer Programming and Tuning Software (CD)	H5197 HKVN4002_

Refer to online help files for the CPS Programming procedures.

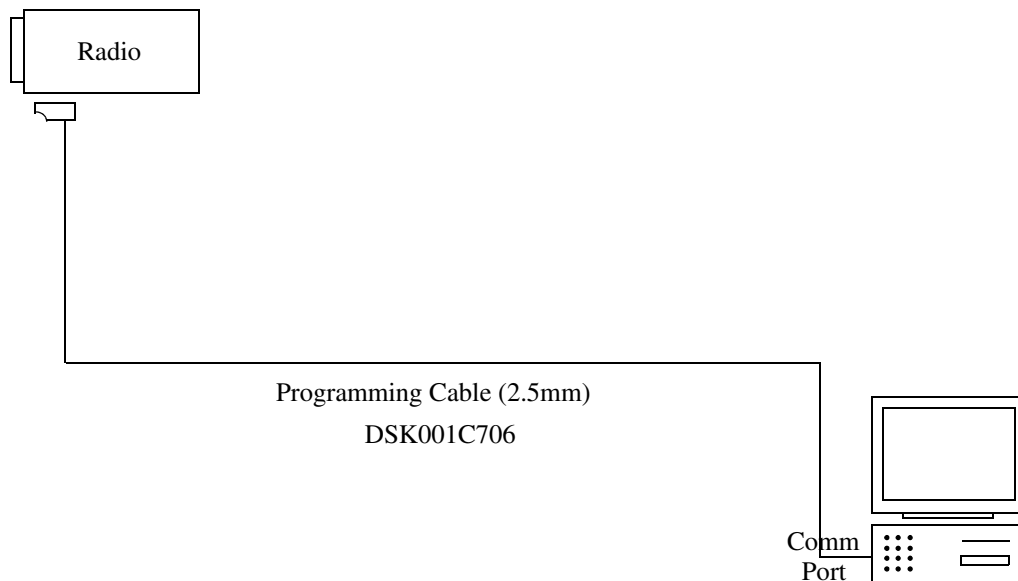

Figure 4-1.

## 4.4 Programming

### 4.4.1 PL Frequencies and Codes

PL Freq (Hz)	Motorola Code	Equiv. PL Code		PL Freq (Hz)	Motorola Code	Equiv. PL Code
67	001	XZ		136.5	022	4Z
69.3	002	WZ		141.3	023	4A
71.9	003	XA		146.2	024	4B
74.4	004	WA		151.4	025	5Z
77	005	XB		156.7	026	5A
79.7	006	WB		162.2	027	5B
82.5	007	YZ		167.9	028	6Z
85.4	008	YA		173.8	029	6A
88.5	009	YB		179.9	030	6B
91.5	010	ZZ		186.2	031	7Z
94.8	011	ZA		192.8	032	7A
97.4	012	ZB		203.5	033	M1
100	013	1Z		206.5	034	8Z
103.5	014	1A		210.7	035	M2
107.2	015	1B		218.1	036	M3
110.9	016	2Z		225.7	037	M4
114.8	017	2A		229.1	038	9Z
118.8	018	2B		233.6	039	M5
123	019	3Z		241.8	040	M6
127.3	020	3A		250.3	041	M7
131.8	021	3B		254.1	042	0Z
				PL1	PL1	
				PL2	PL2	
				PL3	PL3	

**NOTE:** PL1, PL2, PL3 are the User Defined PL Frequencies.

## 4.4.2 DPL Codes

DPL Code	Motorola Code	DPL Code	Motorola Code	DPL Code	Motorola Code	DPL Code	Motorola Code
23	043	152	065	343	087	606	109
25	044	155	066	346	088	612	110
26	045	156	067	351	089	624	111
31	046	162	068	364	090	627	112
32	047	165	069	365	091	631	113
43	048	172	070	371	092	632	114
47	049	174	071	411	093	645*	115
51	050	205	072	412	094	654	116
54	051	223	073	413	095	662	117
65	052	226	074	423	096	664	118
71	053	243	075	431	097	703	119
72	054	244	076	432	098	712	120
73	055	245	077	445	099	723	121
74	056	251	078	464	100	731	122
114	057	261	079	465	101	732	123
115	058	263	080	466	102	734	124
116	059	265	081	503	103	743	125
125	060	271	082	506	104	754	126
131	061	306	083	516	105		
132	062	311	084	532	106		
134	063	315	085	546	107		
143	064	331	086	565	108		

**NOTE:** The codes marked with an asterisk are not part of the 83 standard EIA/TIA-603 codes.

## 4.4.3 Examples

### 4.4.3.1 Setting Up a Scan List

**Scenario:** To setup Scan List 2 with the following channels - CH 008, CH 036, CH 092, CH 083, CH 068.

**Steps:**

1. Enter Programming Mode, by pressing *MON* and turning on the radio.
2. Press PTT or *MON* until **SCANLST2** is displayed.
3. Press **+**. The first scan list member holder, **2-01-**, will be displayed. Use the keypad to enter 008.



4. Press **+** again. Enter 036, when **2-02-** appears, and subsequently in this manner, enter the other channels.

**NOTE:** If a mistake is made, use **+** or **-** to move to the appropriate scan list member holder and press **#** to erase the channel number.

5. Press PTT or *MON*, when all the channel numbers have been entered.
6. Turn off your radio, if you have completed the programming, or proceed to the next parameter.

#### 4.4.3.2 Programming a Phone Number/Access Code/De-Access Code

**Scenario:** To program the phone number, 9-72886338 (where “-” represents a Pause digit), at memory location 8.

**Steps:**

1. Enter Programming Mode, by pressing *MON* and turning on the radio.
2. Press PTT or *MON* until **TELNO-8** is displayed.
3. Press **+**. The cursor will be placed on the first character.
4. Use the keypad to enter **9**.
5. Enter a Pause digit, by entering \* followed by **#**. These two characters will be converted into a Pause, represented by ‘-’.

**NOTE:** Each Pause digit entered shortens the overall length of the code/number by a digit.

6. Use the keypad to enter the rest of the phone number.

**NOTE:** If a mistake is made, use **+** or **-** to move to the appropriate location and then re-enter the correct character. To erase the complete phone number/code, enter **#** 16 times.

7. Press PTT or *MON*, when the complete phone number has been entered.
8. Turn off your radio, if you have completed the programming, or proceed to the next parameter.

**This Page Intentionally Left Blank**

---

## Chapter 5 Error Code Displays

### 5.1 Error Codes

The radio performs cursory tests during start-up and during operations to determine if its basic electronics and software are in working order. Problems detected during these tests are presented as error codes on the radio display. The presence of an error code means that a problem exists and that the user should contact a service technician. Use the following table to aid in understanding particular error code displays.

*Table 5-1.*

<b>Failure Display</b>	<b>Description</b>
MEM ERR	Defective ROM.
EEP ERR	Defective external EEPROM. Codeplug data is corrupted.
PLL ERR	The radio cannot receive or transmit on the programmed frequencies.

**This Page Intentionally Left Blank**

---

## Chapter 6 Accessories

### 6.1 Antennas

8504762J01_	14cm Antenna, 136-155MHz
8504762J02_	14cm Antenna, 155-174MHz
PMAD4012_	9cm Antenna, 136-155MHz
PMAD4013_	9cm Antenna, 155-174MHz
PMAE4010_	10cm Antenna, 403-440MHz
PMAE4011_	10cm Antenna, 435-480MHz
NAE6483_	Whip Antenna, 403-520MHz

### 6.2 Carrying Accessories

4285820Z01	Shoulder Strap
HLN9844_	Belt Clip (1.5")
HLN9985_	Waterproof Bag
RLN4815_	Universal RadioPak Carry Case
JMZN4020_	Handstrap for Radio

### 6.3 Carry Cases

PMLN4467_	Carrying Case, Soft Leather Black
PMLN4468_	Carrying Holster Case, Neoprene Grey
PMLN4469_	Carrying Holster Case, Neoprene Blue

### 6.4 Chargers

PMTN4047_	Wall Charger (16Hr), 230V, EU
PMTN4052_	Wall Charger (16Hr), 230V, UK
PMTN4053_	Wall Charger (16Hr), 110V, US
HTN9071_	Wall Charger (24Hr), 230V, ARG
PMTN4049_	Rapid Charger (3Hr), 230V, EU
PMTN4050_	Rapid Charger (3Hr), 240V, UK
PMTN4048_	Rapid Charger (3Hr), 110V, US

### 6.5 Batteries

PMNN4046_	Battery Std NiMH
-----------	------------------

### 6.6 Audio Accessories

PMLN4442_	MAG ONE Earbud w/In-line PTT/MIC/Vox Switch
-----------	---

---

---

PMLN4443_	MAG ONE Ear Receiver w/In-line PTT/MIC/Vox Switch
PMLN4444_	MAG ONE Earset Boom Mic w/In-line PTT/Vox Switch
PMLN4445_	MAG ONE Ultra-lightweight Headset w/in-line PTT/Vox
PMMN4008_	MAG ONE Remote Speaker Mic
HMN9030_	Remote Speaker Microphone
PMLN4294_	Ear Set Microphone w/PTT
PMLN4425_	Earset Boom Mic w/Remote Ring PTT
BDN6646_	Ear Mic w/PTT
BDN6647_	Lightweight Single Speaker w/Swivel
BDN6648_	Hvy-duty Hdset w/Noise Canceling Mic
BDN6720_	Flex Rec. Earpiece w/o Volume Control
HMN9022_	Medweight Dual Muff Headset (behind)
HMN9752_	Earpiece w/Volume Control
HMN9787_	Lightweight Headset w/Swivel Boom Mic
HMN9013_	Lightweight Headset w/Swivel Boom Mic
HMN9021_	Medweight Dual Muff Headset (overhead)
HMN9036_	Earbud w/clip Mic and PTT
HMN9727_	Earpiece w/o Volume Control

## 6.7 Manuals

HKLN4197_	PRO2150 Portable Radio User Guide (English, Spanish, and Portuguese)
HKLN4204_	PRO2150 Portable Radio Detailed Service Manual (English)

## 6.8 Software

H5197	2 Year CPS Subscription
HKVN4002_	PRO2150 Customer Programming and Tuning Software (CD)

# Chapter 7 VHF Band Information

## 7.1 Model Chart

PRO2150 Portable Radio, VHF, 136-174 MHz		
Model		Description
LAH49KDH8AA9_N		PRO2150, 136-174MHz, 1-5W, 12.5/25K-99ch
	<b>Item</b>	<b>Description</b>
X	PMUD1738__L	PRO2150, 136-174MHz, 1-5W, 12.5/25K
X	DS1M001110	Front Cover Kit
X	DS1M001120	Chassis Hardware Kit
X	DS1M001130	Knob Assembly
X	DS1M001140	Ext. Cover Kit
X	DS1M001150	Controller Board Assembly VHF PRO2150
X	DS1M001160	RF Board Assembly
X	DS1M001170	LCD Kit
X	DS1M001190	Speaker Assembly
X	DSM1B26051	Screw M2.6
X	DSM2192004	Contact Gasket
X	DSM2192005	Main Gasket
X	DSM2192006	Volume Gasket
X	DSM4193013	Gasket (Screw 26)
X	DSM5190001	Housing, Back
X	DSM6189003	PTT Button
X	PMNN4046_	Battery Std NiMH
X	PMAD4012_	VHF 9cm Antenna, 136-155MHz
X	PMAD4013_	VHF 9cm Antenna, 155-174MHz
X	PMAD4014_	VHF 15cm Antenna, 136-155MHz
X	PMAD4015_	VHF 15 cm Antenna, 155-174MHz
X	PMTN4053_	Std Wall Charger 110V US
X	DSM4193042	PRO2150 Nameplate
X	HLN9844_	Belt Clip
X	HKLN4197_	PRO2150 Portable Radio User Guide CD (English, Spanish, and Portuguese)

x = Indicates one of each is required.

## 7.2 Specifications

### General

	VHF	
Frequency:	136-174 MHz	
Channel Capacity:	99	
Power Supply:	7.5 Volts $\pm$ 20%	
Dimensions with Standard High Capacity NiMH Battery:	115.5mm x 56mm x 35mm	
Weight: with Standard High Capacity NiMH Battery:	350 g	
Average Battery Life @ (5-5-90 Duty Cycle)	(Low Power) >11 hrs	(High Power) >8 hrs
Sealing:	Passes rain testing per IPX4 (EN60529=1991)	
Shock and Vibration:	Meets MIL STD 810C, D and E	
Dust:	Meets MIL STD 810C, D and E	
Humidity:	Weather resistant housing passes EIA RS-316B	

### Transmitter

	VHF	
RF Output NiMH @ 7.5V:	Low 1W	High 5W
Channel Spacing	12.5/25 kHz	
Freq. Stability (-30°C to +60°C)	0.00025%	
Spurs/Harmonics:	-26 dBm	
Audio Response: (from 6 dB/oct. Pre-Emphasis, 300 to 3000Hz)	+1, -3 dB	
Audio Distortion: @ 1000 Hz, 60% Rated Max. Dev.	<5%	
FM Noise:	40 dB	

### Receiver

	VHF 12.5 kHz	VHF 25 kHz
Sensitivity 12dB SINAD:	0.25 $\mu$ V	0.25 $\mu$ V
Adjacent Channel Selectivity EIA	60 dB	65 dB
Intermodulation	60 dB	65 dB
Spur Rejection:	60 dB	65 dB
Image Rejection:	60 dB	65 dB
Hum and Noise	40 dB	
Audio Distortion	< 5%	
Conducted Emmission	-57 dBm	
Audio Output @ <5% Distortion	500 mW	500 mW

All specifications are subject to change without notice.



## 7.3 Theory of Operation

### 7.3.1 General Information

Your radio has two printed circuit boards: the Controller board, and the Radio Frequency (RF) board. The Controller board contains the CPU/Control section. The RF board contains the VCO/Synthesizer section, Transmitter section, Receiver section, Transmitter Audio circuitry, Receiver Audio circuitry, and Battery section.

### 7.3.2 Power Distribution

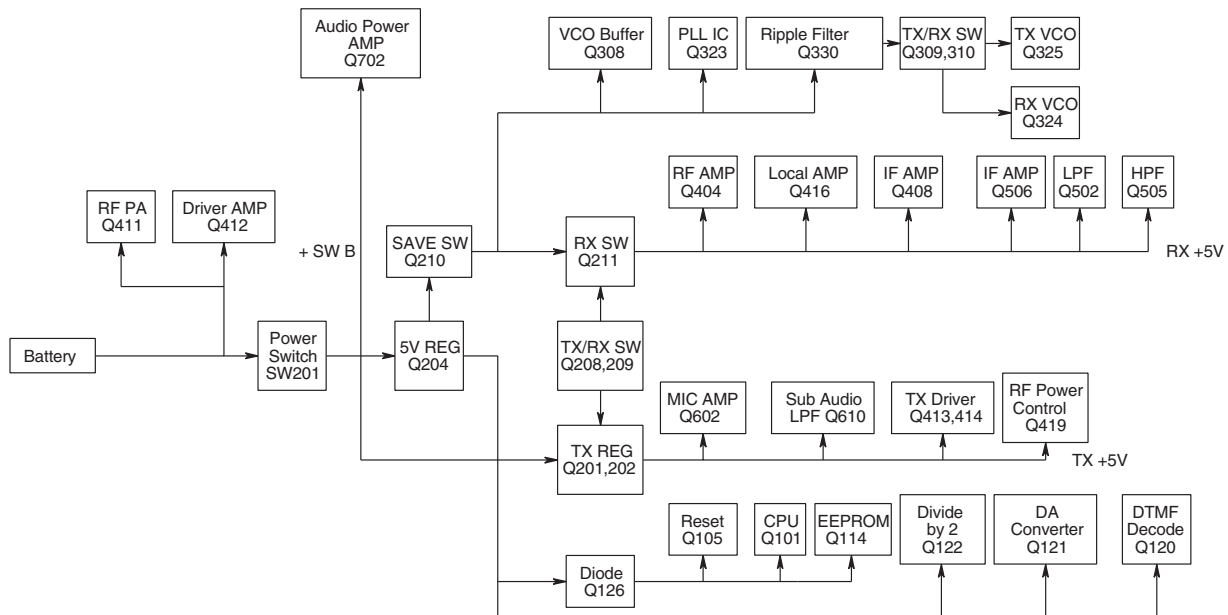

Figure 7-1.

The above figure illustrates the DC distribution throughout the radio board. A battery supplies power directly to the electronic on/off control. Radio power supply is triggered by the **Power Switch** (On/Off/Volume control) and **+SW B** is distributed as show in the figure. Regulator output 5V is supplied to the CPU. **+SW B** continues to support the Audio Power AMP, 5V Regulator, TX Regulator until the radio is turned off.

The radio can be turned off on two ways:

1. **Power Switch** turned-off
2. Low Battery

When a low battery level is detected by the CPU, it stores the radio personality data to EEPROM before turning off the radio.

### 7.3.3 Power up Sequence

1. Power supply is turned on by the On/Off/Volume Control (Power Switch).
2. Power from battery is supplied to the regulator through the switch.
3. Output (5V) from the regulator is directed to the CPU (**Q101**).
4. **Q105** resets the CPU (**Q101**).
5. The CPU loads radio personality data from EEPROM after the reset.
6. This personality data is used to initialize the radio.

7. The radio restores last power up state (i.e. state before the radio was turned-off).
8. Power is supplied to PLL circuitry.
9. Power is supplied to Rx and Rx VCO circuitry.
10. CPU sends data to PLL circuitry. If LOCK status is confirmed, radio continues the power-up sequence. Otherwise, PLL ERR is displayed.
11. If the Rx audio level is less than the pre-programmed squelch level, and other unmuting conditions are met, the radio will open squelch.

### 7.3.4 CPU / Control Section

When the radio is turned ON, the CPU (**Q101**) reads the radio status from the EEPROM **Q114**. It also monitors the keypad, the PTT line and other inputs such as the squelch detect, etc. continuously. When there is a channel change, the CPU sends the correct frequency information to the synthesizer via pins 1, 2 and 89. The CPU is clocked by the 8.388608MHz oscillator, which is composed of **X101**, **C101**, **C106**, and **R158**.

### 7.3.5 VCO / Synthesizer Section

This section consists of the Temperature-Compensated Crystal Oscillator (TCXO), Voltage Controlled Oscillator (VCO), Synthesizer and the Loop Filter. These circuits are found on the RF board.

#### 7.3.5.1 Temperature-Compensated Crystal Oscillator (TCXO)

The reference oscillator is a temperature compensated crystal-controlled, Pierce type circuit. It utilizes a logic gate within **Q323** as a gain element. **C335** is used to adjust the oscillator on frequency (14.4MHz) at room temperature (22°C). Temperature variations cause resistance changes in thermistor **R330** and **R567**, which is on the base of **Q320**, thus varying the voltage applied to varactor **Q322**. This changes the impedance across crystal **X301** in a manner complementary to the temperature drift characteristic of the crystal. In this way, the reference oscillator is held within the specified  $\pm 2.5$  PPM from -30 to +60°C.

#### 7.3.5.2 Voltage-Controlled Oscillators

Only one of the VCOs runs at a time, which is controlled by **Q310** and **Q101**. The receive VCO consists of **C344-C351**, **L302**, **L305**, **L306**, **L312-L314**, **Q311**, and **Q324**. This VCO oscillates at 45.1 MHz above the programmed receive frequency. The VCO's oscillating frequency is tuned by the varactor **Q311**. The tuning voltage is supplied from the output of the Loop Filter. The output of the VCO is AC coupled (**C352**) to the buffer **Q308**. The output of the VCO buffer **Q308** is AC coupled (**C308**) to the synthesizer and the output buffer **Q416** respectively.

When the PTT is pressed, **Q101** pin36 goes low (approx. 0V) disabling the receive VCO by the **Q310** and biases on **Q309** to enable the transmitter VCO. The transmitter VCO consists of **C353**, **C355**, **C357**, **C358**, **L315**, **L317**, **L318**, **Q325**, **Q326**, and **Q329**. This VCO oscillates on the programmed transmit frequency. The VCO's oscillating frequency is tuned by the varactor **Q326**. The tuning voltage is supplied from the output of the Loop Filter. The transmit voltage controlled oscillator is directly frequency-modulated and operates on the carrier frequency. The synthesizer is tuned in 5.00kHz or 6.25kHz steps.

#### 7.3.5.3 Synthesizer

The frequency synthesizer is a large-scale monolithic synthesizer integrated circuit **Q323**. The synthesizer IC contains a dual modulus prescaler, programmable divide-by-N counter, prescale control (swallow) counter, reference oscillator, reference divider, phase detector, charge pump and lock detector. Also, included in **Q323** are shift registers and control circuits for frequency controls and general device control.

RF output from the active VCO is AC coupled to the synthesizer **Q323** prescaler input at Pin 8. The divide counter chain in **Q323**, consisting of the dual-modulus prescaler, swallow counter and programmable counter, divides the VCO signal down to a frequency very close to 5.00kHz or 6.25kHz which is applied to the phase detector. The phase comparator compares the phase with the 5.00kHz or 6.25kHz reference signal from the reference divider and drives the external charge pump (**Q314**, **Q315** and **Q316**). The synthesizer unlock detector circuit prevents the operation of the transmitter and receiver, when the phase lock loop (PLL) is unlocked. The following discussion assumes the unit has been placed in the transmit mode. **Q323** lock detector Pin 7 goes high when the PLL is locked. This high level is applied to Pin 25 of the CPU **Q101**. A software timing routing brings the RX/TX line low (Pin 36 of **Q101**). With the RX/TX line goes low, **Q209** is cut off and **Q208** is biased on passing **+5VTX-B** to **Q202**; it biases on **Q201** to pass switched **TX-B** to the transmitter amplifier string which enables transmission.

When the PLL is unlocked, the lock detector at **Q323** Pin 7 will begin pulsing low. A RC circuit converts this low pulse to a low level for the CPU. The CPU then changes the RX/TX line to a high, thus signaling the other transistor switches to drive **Q201** into cutoff, which disables transmission. Therefore, the transmitter remains disabled while the loop remains out of lock, and "PLL ERR" is displayed.

#### 7.3.5.4 Loop Filter

The Loop Filter, a passive lead-lag filter consisting of **R314-R317**, **R356**, **C323**, **C369**, and **C371**, integrates the charge pump output to produce the DC turning voltage for the VCO. One parasitic pole, consisting of RF chokes **L306/L318**, prevent modulation of the VCOs by the 5.00kHz or 6.25kHz reference energy remaining at the output of the loop filter. Direct FM is obtained for modulating frequencies outside the PLL bandwidth by applying the CTCSS/DCS signals and the pre-emphasized, limited microphone audio to the VCO modulation circuit. The modulation circuit consists of **R347** and **Q329**.

### 7.3.6 Transmitter Section

#### 7.3.6.1 RF Power Amplifier

After the PTT is pressed, the **+5VTX-B** line switches to approximately 5V. **Q309** is turned on, enabling transmit VCO. The VCO buffer, pre-driver, driver and power amplifier are biased on by **Q201**. **Q201** is biased on by the **+5VTX-B** line switching to 5V. RF output from the transmit VCO(**Q325**) is applied to the VCO output buffer **Q308**. Output from **Q308** feeds the buffer **Q414**. The output signal from **Q414** feeds the pre-driver amplifier **Q413**, and feeds the driver amplifier **Q412**, whose output from the driver stage feeds the final RF power amplifier **Q411** to produce the rated output power of 5 watts. The final output is feed to a low-pass filter (**C446-C448**, **C451**, **C452**, **L418**, and **L419**) and then to the transmit/receive switch **Q410**. RF power is then fed to the antenna via the output low-pass filter consisting of **C440-C445**, **L415**, and **L416**.

#### 7.3.6.2 Antenna Switching

Switching of the antenna between the transmitter and the receiver is accomplished by the antenna transmit/receive switch consisting of diodes **Q409** and **Q410**. In the transmit mode, switched **TX B+** is applied through **R419** and RF choke **L417**, hard forward biasing the two diodes on **Q410**, thus permitting the flow of RF power from the output of the low-pass filter. **L414** and **C445** isolate the receiver circuit from the transmitter power input.

### 7.3.6.3 Power Control

Output power is controlled by the CPU (**Q101**), the D/A converter (**Q121**), the dual Op-Amp (**Q419**), which is used as a differential amplifier and comparator. Current is sensed by the voltage drop across **R445**. When the radio is in high power mode, this voltage is compared to the D/A converter voltage at 5-watt. When the radio is in low power mode, this voltage is compared to the D/A converter voltage at 1-watt. The power output is then reduced or increased by varying the applied voltage to the gate of the power amplifier **Q411** and **Q412**.

### 7.3.6.4 Transmitter Audio Circuits

The transmitter audio circuits consist of the audio processing circuits, the CTCSS circuits and the DCS circuits.

#### 7.3.6.4.1 Audio Processing

Transmit speech audio is provided by either the internal electric microphone **M101** or the external microphone. The audio is pre-emphasized by 6dB per octave by **C615** and **R655**, and then its signal is amplified. The microphone audio is directed to amplifier **Q602B**, **Q602A** and low-pass filter **Q602C** and **Q602D**. **Q602A** has limiting function. The modulation adjustment is done by Pot **RV601**, and directed to a four-pole active low-pass filter. The resulting signal is then limited, and is directed to a low pass filter (18dB per octave roll-off above 3KHz). The audio is then directed through the 25KHz/12.5KHz channel spacing SW **Q601** to varactor diode **Q329** in transmit VCO. By varying the voltage on the varactor diode **Q329** at an audio rate, VCO output is frequency-modulated.

#### 7.3.6.4.2 CTCSS Tone Encoder / Digital Code Squelch (DCS) Encoder

CTCSS signals and DCS signals are synthesized by CPU **Q101** and appear as pulse waveform on I/O line Pin 7. This I/O line is connected to a digital-to-analog converter network (consisting of **C136**, **C173**, **R150**, **R177** and **R182**), which produces a pseudo-sine wave at its output. The waveform is smoothed by low pass filters **Q610B** to produce an acceptable sine wave output. The CTCSS tone signal is adjusted to the proper level by **RV602**.

## 7.3.7 Receiver Section

### 7.3.7.1 Receiver Front End

In the receive mode, the RF signal enters through the antenna, then through the low-pass filter **C439-C445**, and **L414-L416**. The diodes **Q409** and **Q410** are biased off, so that the output of the low-pass filter is coupled (**C437**, **C438**, **L413** and **R418**) to the first band-pass filter **C401-C406**, **C408-C410**, **L401**, **L402**, **PCB\_L1**, **Q401**, **R401**, and to the Front End RF overload protection diode pair **Q403**. The signal from the band-pass filter is directed to the input of the RF amplifier **Q404**. The output of the RF amplifier is sent to three stages of band-pass filters, consisting of **C415-C429**, **C486**, **L404-L406**, **Q405** and **R410**. The output from the band-pass filter is directed to the mixer's **Q407/L407**.

### 7.3.7.2 Local Oscillator (LO)

The Receive VCO (**C344-C351**, **L302**, **L305**, **L306**, **L312-L314**, **Q311**, and **Q324**) provides the LO signal. The VCO is running at 45.1 MHz above the desired receive frequency and is applied to output Buffer **Q308/Q416**. The output of the buffer is sent through the low-pass filter **C430**, **C431**, **L409**, and to the mixer **Q407/L408**.

### 7.3.7.3 Mixer

The mixer is a DBM type (**L407**, **Q407**, **L408**). The mixer LO frequency is 45.1 MHz above the desired receiver frequency. When the receiver frequency is present, the mixer output will be a 45.1MHz signal. The mixer output is peaked for 45.1MHz at **L410**, **C432** and **R413**, and the signal is filtered by crystal filter **F402** and amplified by **Q408** before being sent to IF IC **Q506**. The 45.1MHz IF signal and LO frequency of 44.645 MHz (**X501**) are mixed in **Q506**. The 455kHz ceramic filter, **F501** or **F502**, filters the second mixer's output. The resulting signal is the second IF signal. The mixer's output is then fed to the internal limiting amplifier, and consequently to the FM decoder.

### 7.3.7.4 FM Detector and Squelch

The FM detector output is used for squelch, decoding tones and audio output. The squelch amplifier is inside of **Q506**, and its output is fed to an internal rectifier and squelch detector. The output on **Q506** Pin 14 signals the CPU **Q101** with a low (~0V) to unmute the radio. The audio is unmuted by the CPU **Q101** Pin 41 switching to a high (5V), thus biasing on **Q503**. The audio is then routed to the audio amplifier **Q702** via the volume control **SW201**.

### 7.3.7.5 Receiver Audio Circuit

The detector's audio output also is fed to the tone (CTCSS and DCS) low-pass filter **Q505A**. Then the output of the low-pass filter is routed to the second stage filter **Q505B**. The output of **Q505B** is passed to **Q505C**. The output of **Q505C** is directed to the squaring circuit **Q505D**, and finally to the CPU **Q101** Pin22 for decoding.

The detector output feeds the audio high-pass filter **Q502**. The output of the audio high-pass filter feeds the Volume Control **SW201** (VOL). From the wiper arm on the Volume Control, the audio is routed to Pin 4, which is the input to the audio power amplifier **Q702**. The output of the audio power amplifier is routed through the earphone jack **J701** to the internal speaker **SP701**.

## 7.3.8 Battery Section

The battery connects to the contact (**CN201**). The positive terminal of the battery connects to the ON/OFF Volume control switch (**SW201**), and the negative terminal connects to PWB ground. Low battery is detected by **R127/R128** and voltage regulator **Q204**.

Battery voltage status is monitored by Pin 19 of the CPU **Q101** through **R127/R128**. When the battery voltage goes below the threshold voltage, "LOW BATT" is displayed on LCD **LC101**. In the BATTERY SAVER Mode, the CPU **Q101** generates a square wave signal on Pin 37. The signal's duty cycle varies according to what the BATTERY SAVE TIMER is set. When the signal goes high (approximately 5 V), **Q210** is biased off, and **Q211** is cut off, thus turning the supply off to IF IC **Q506**.

## 7.4 Block Diagrams

### 7.4.1 Complete

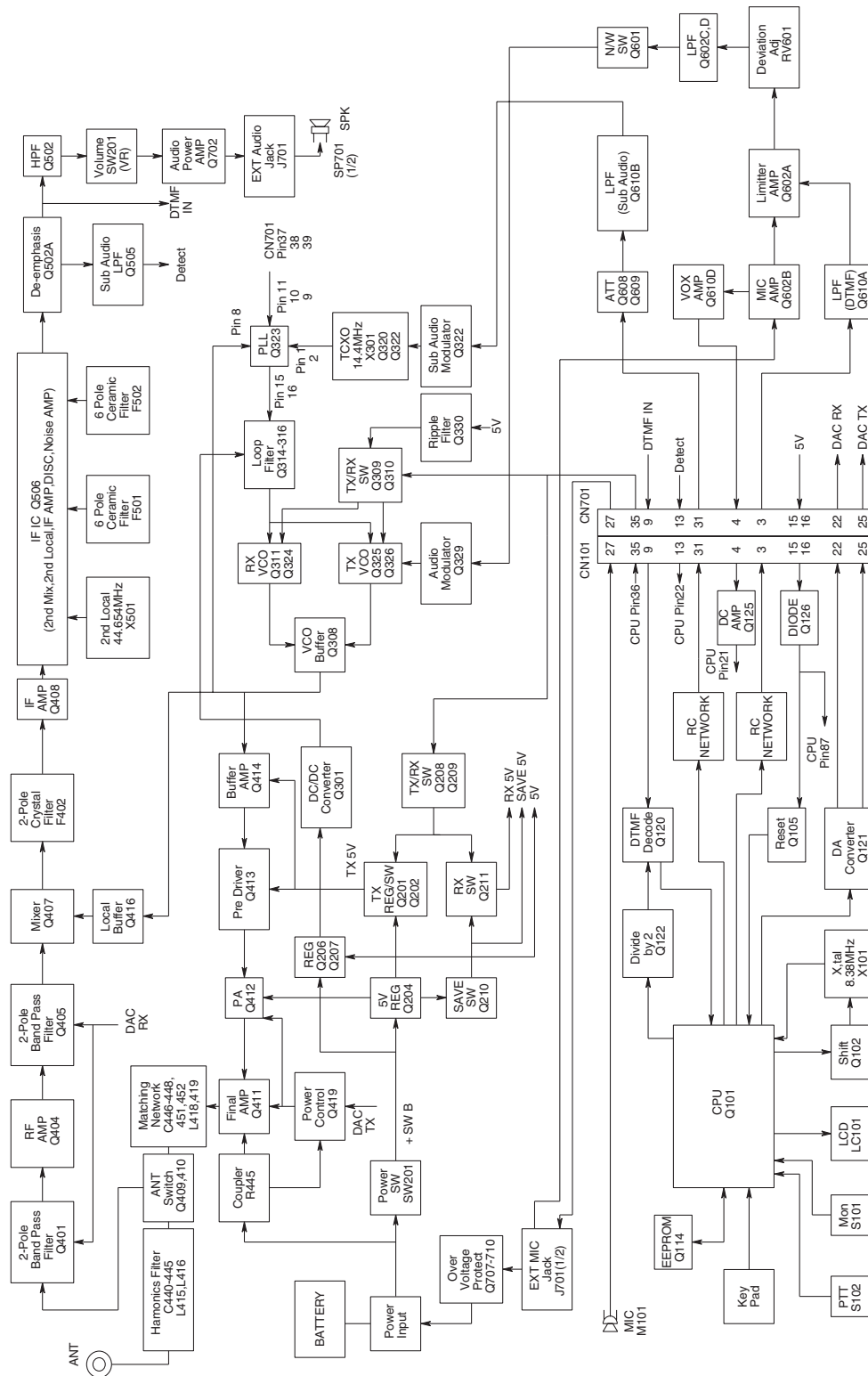

Figure 7-2.

### 7.4.2 Controller

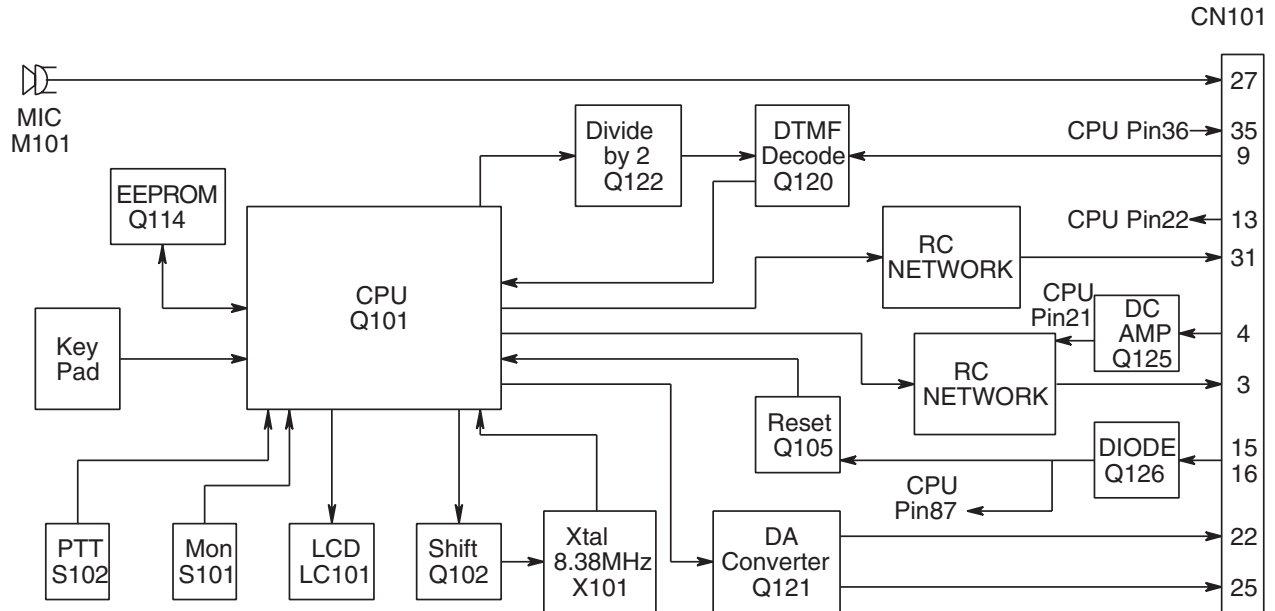

Figure 7-3.

### 7.4.3 VCO

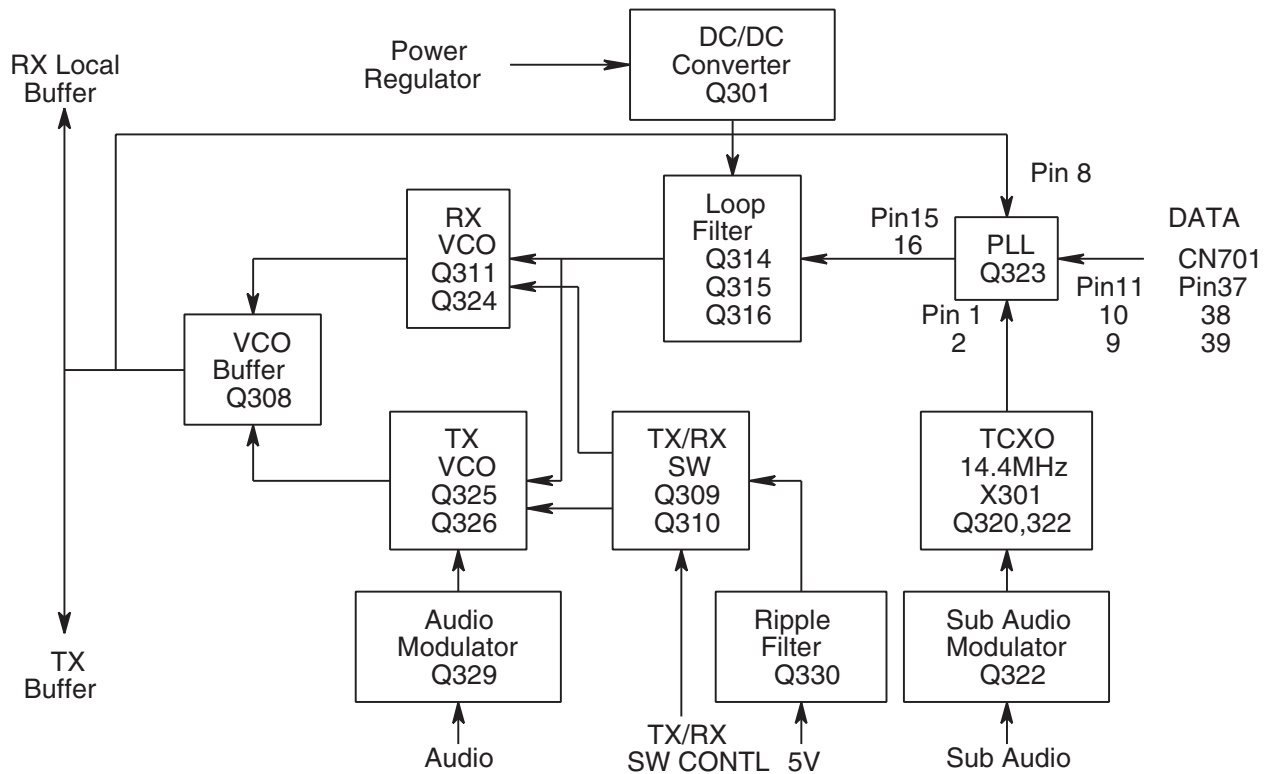

Figure 7-4.

### 7.4.4 Transmitter

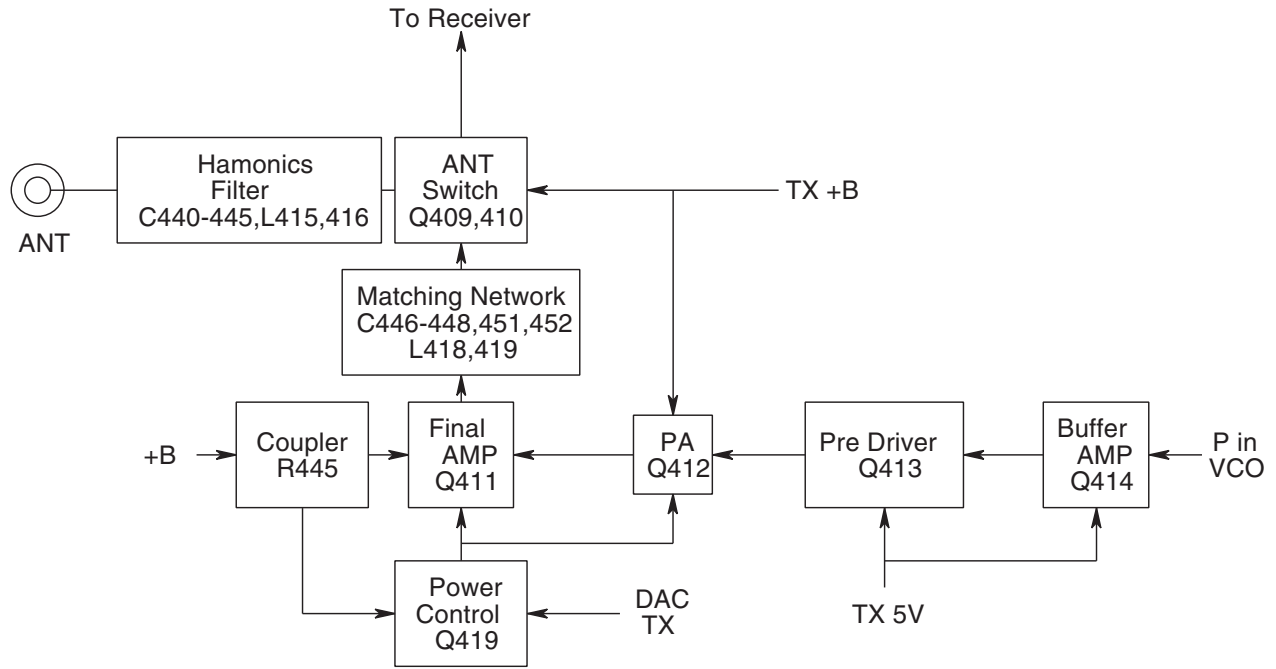

Figure 7-5.

### 7.4.5 Receiver

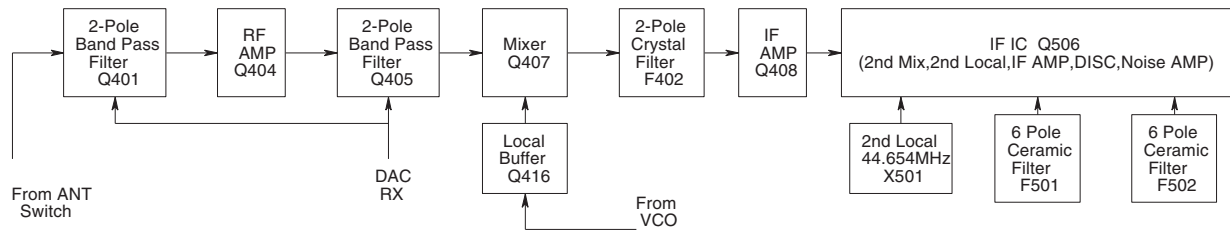
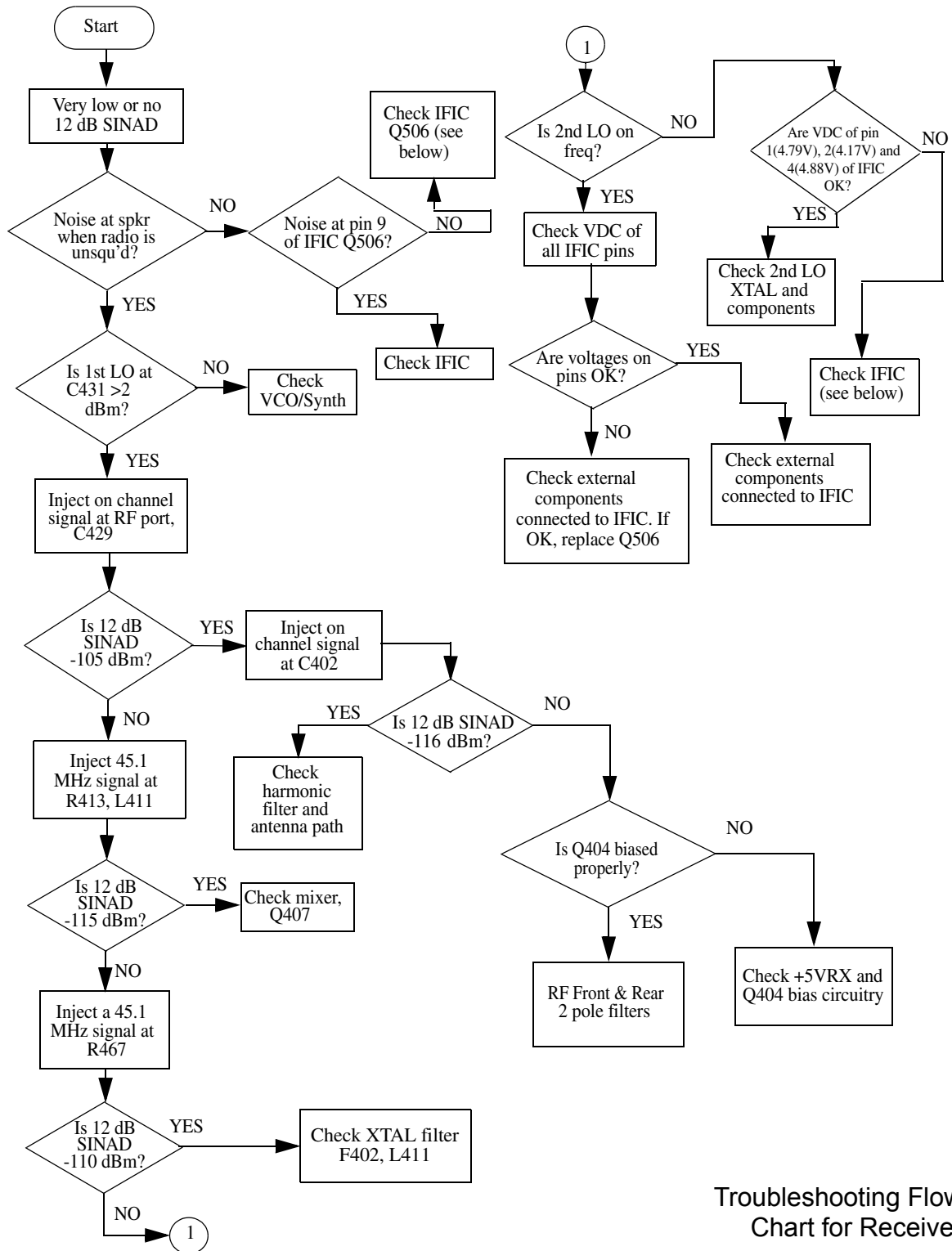

Figure 7-6.



## 7.5 Troubleshooting Charts



Troubleshooting Flow Chart for Receiver

Figure 7-7.

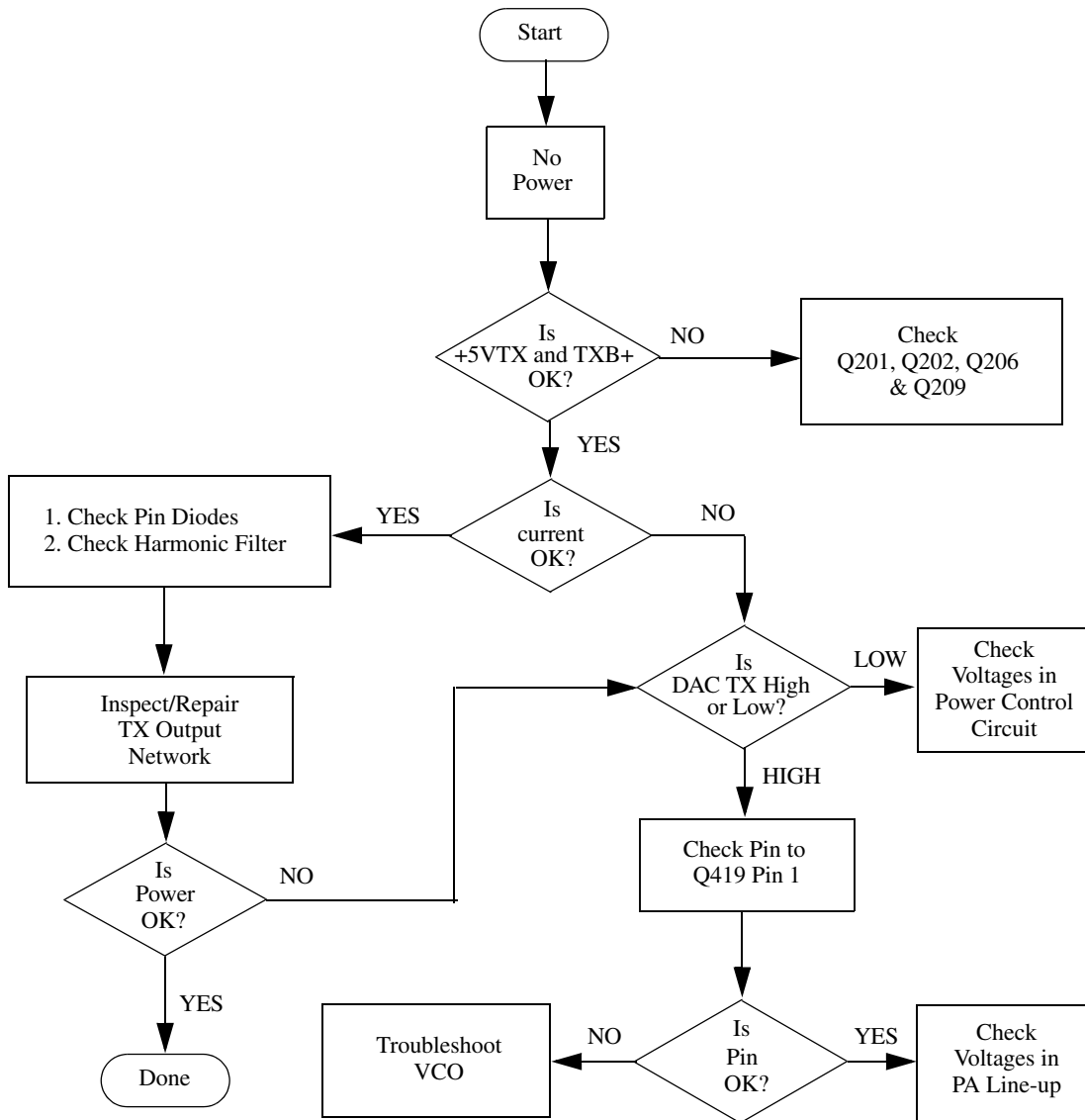

Troubleshooting Flow Chart for Transmitter

Figure 7-8.

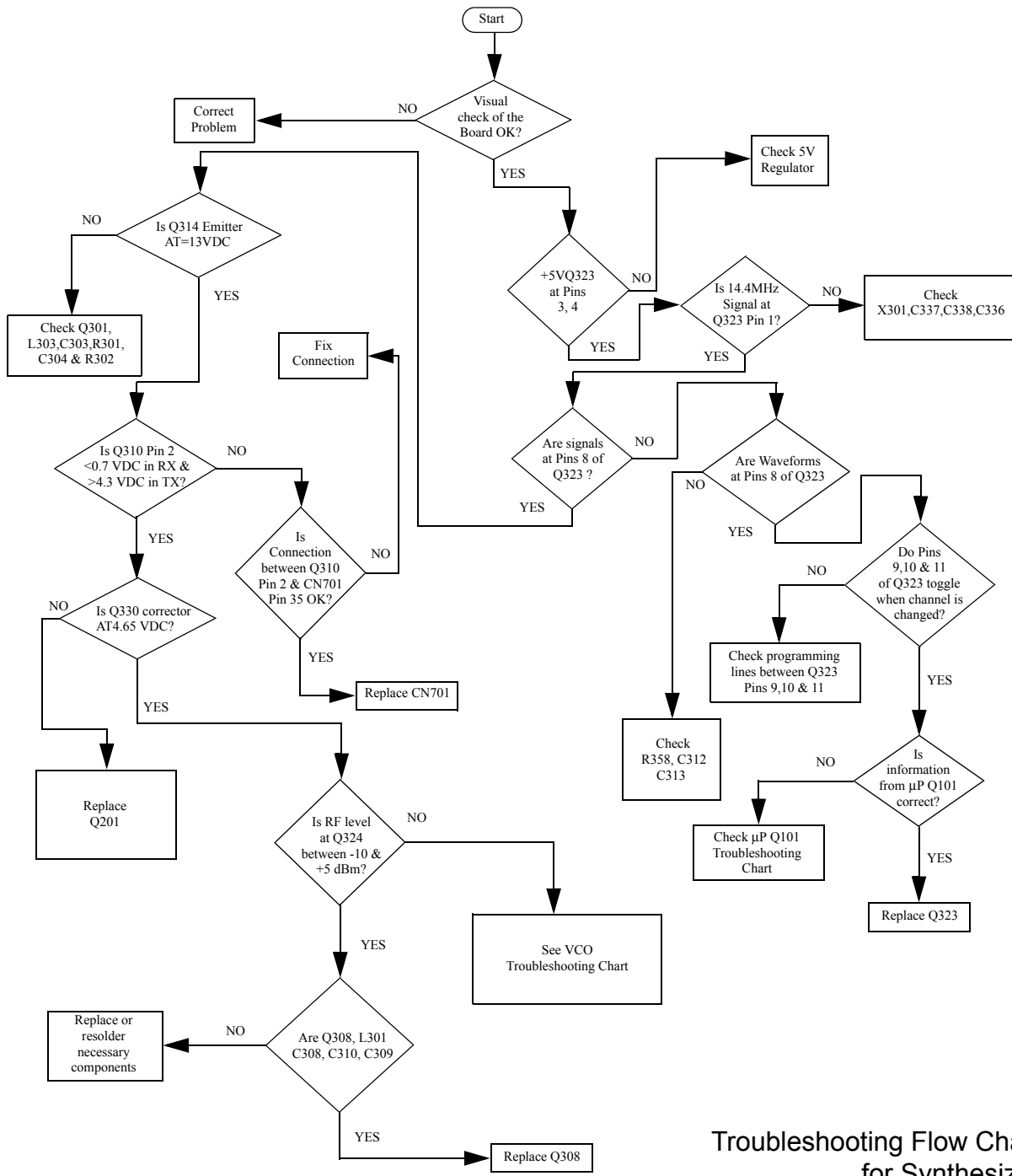

Troubleshooting Flow Chart for Synthesizer

Figure 7-9.

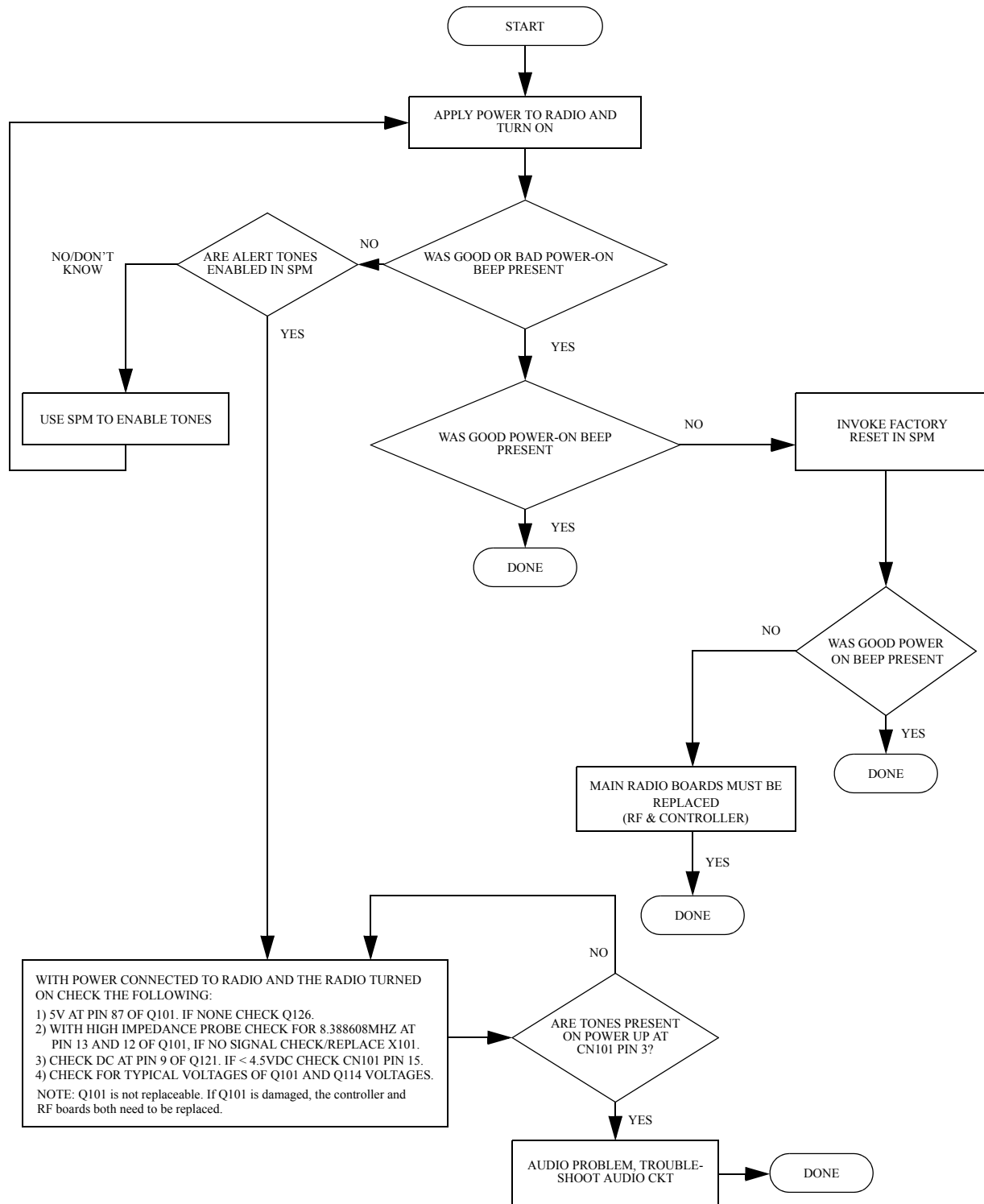

Troubleshooting Flow Chart for Microcontroller

Figure 7-10.

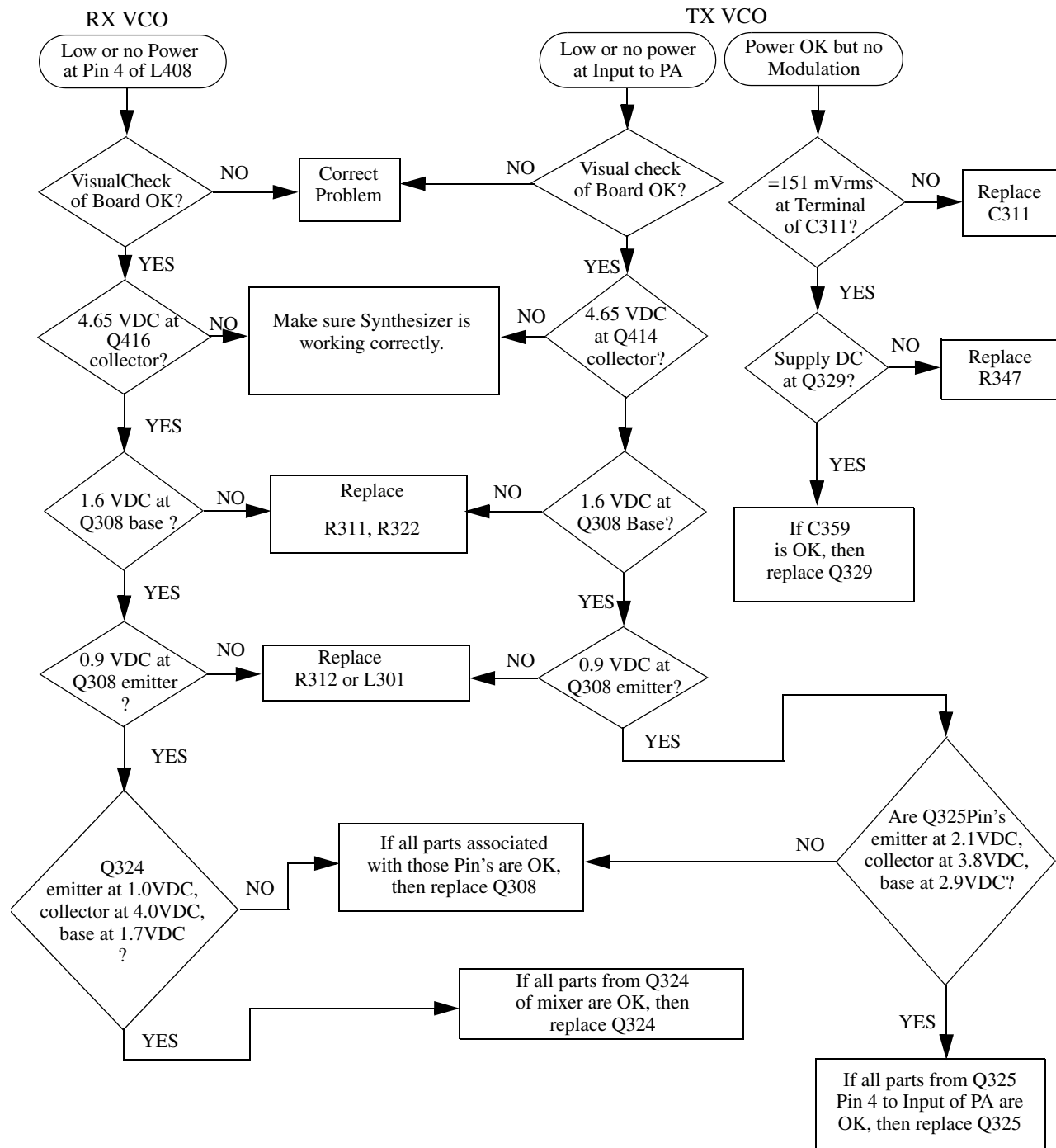

Note: Test Frequency 158MHz

Troubleshooting Flow Chart for VCO

Figure 7-11.

**This Page Intentionally Left Blank**

---

**Chapter 7 VHF 136-174 MHz Circuit Board/Schematic Diagrams and Parts List**

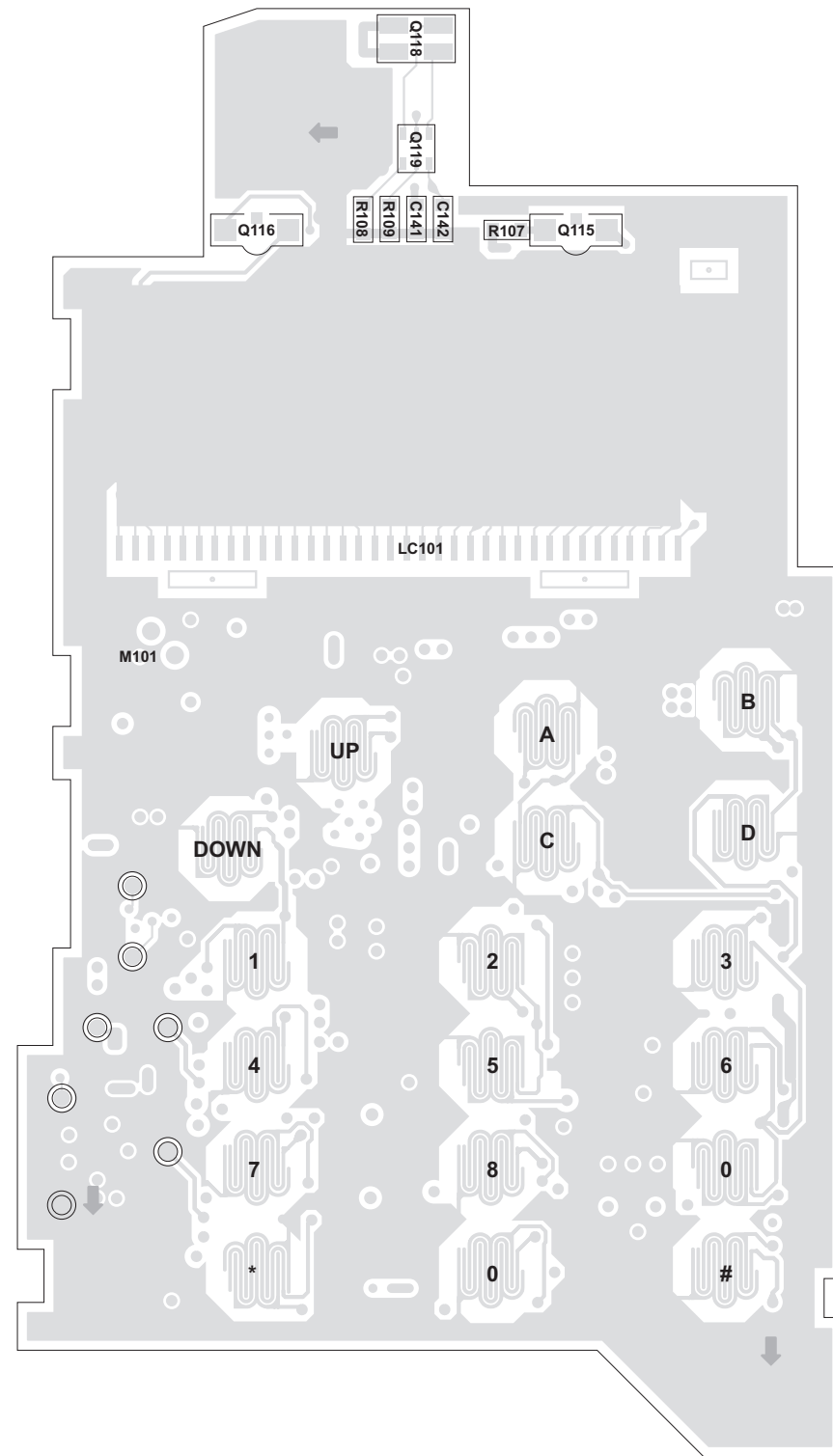

**Top Side**

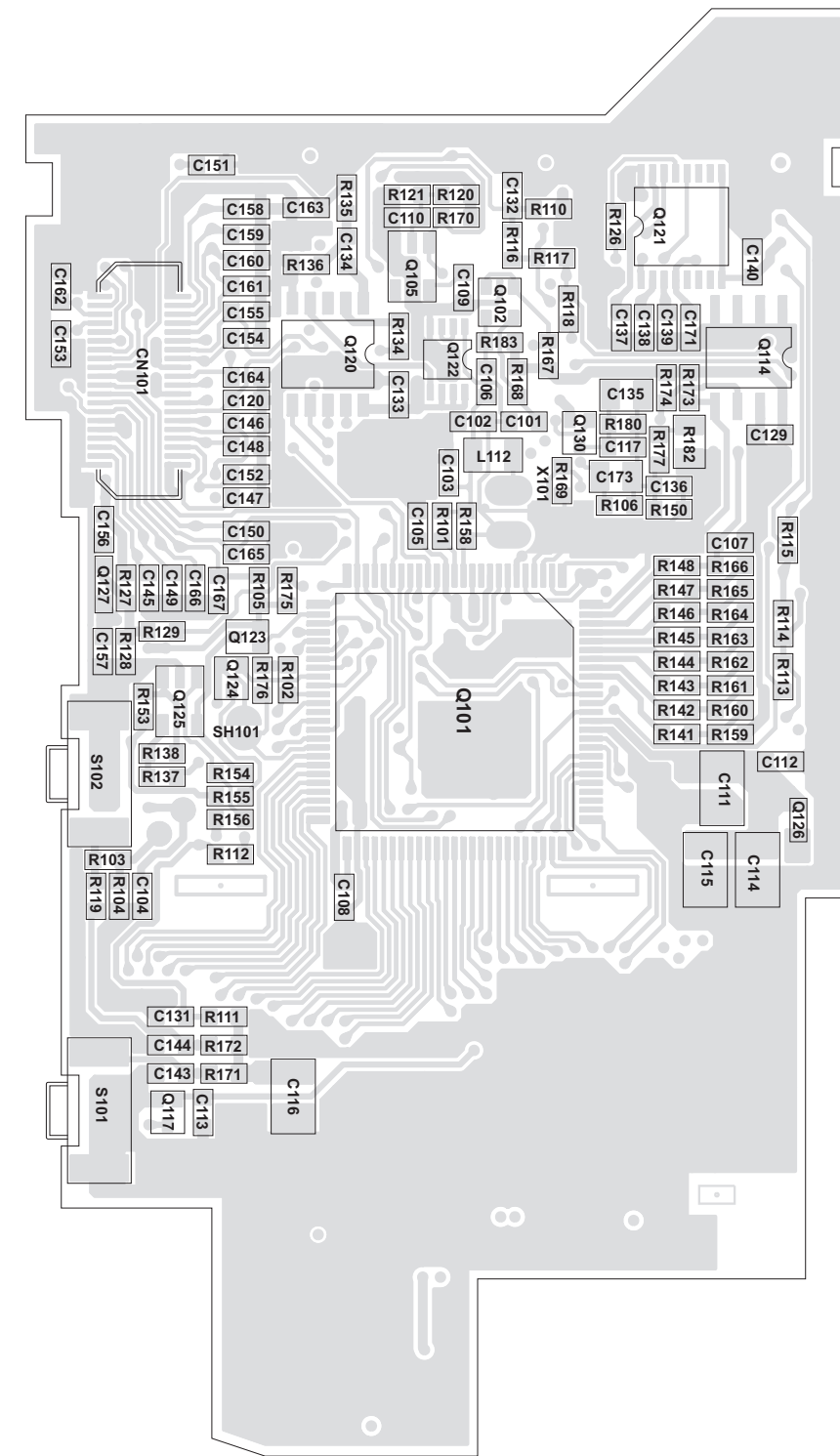

**Bottom Side**

Figure 7-12. VHF 136-174 MHz Controller Board





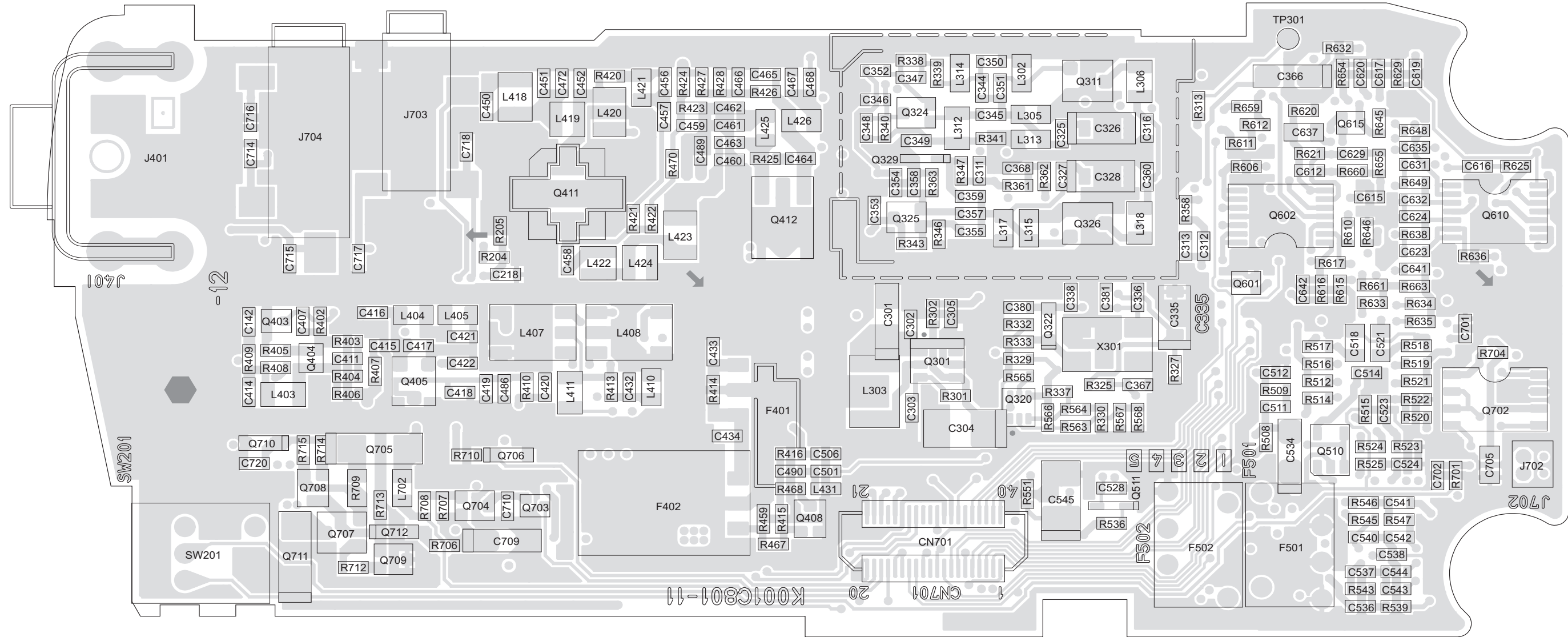

Figure 7-14. VHF 136-174 MHz Main Board Top Side

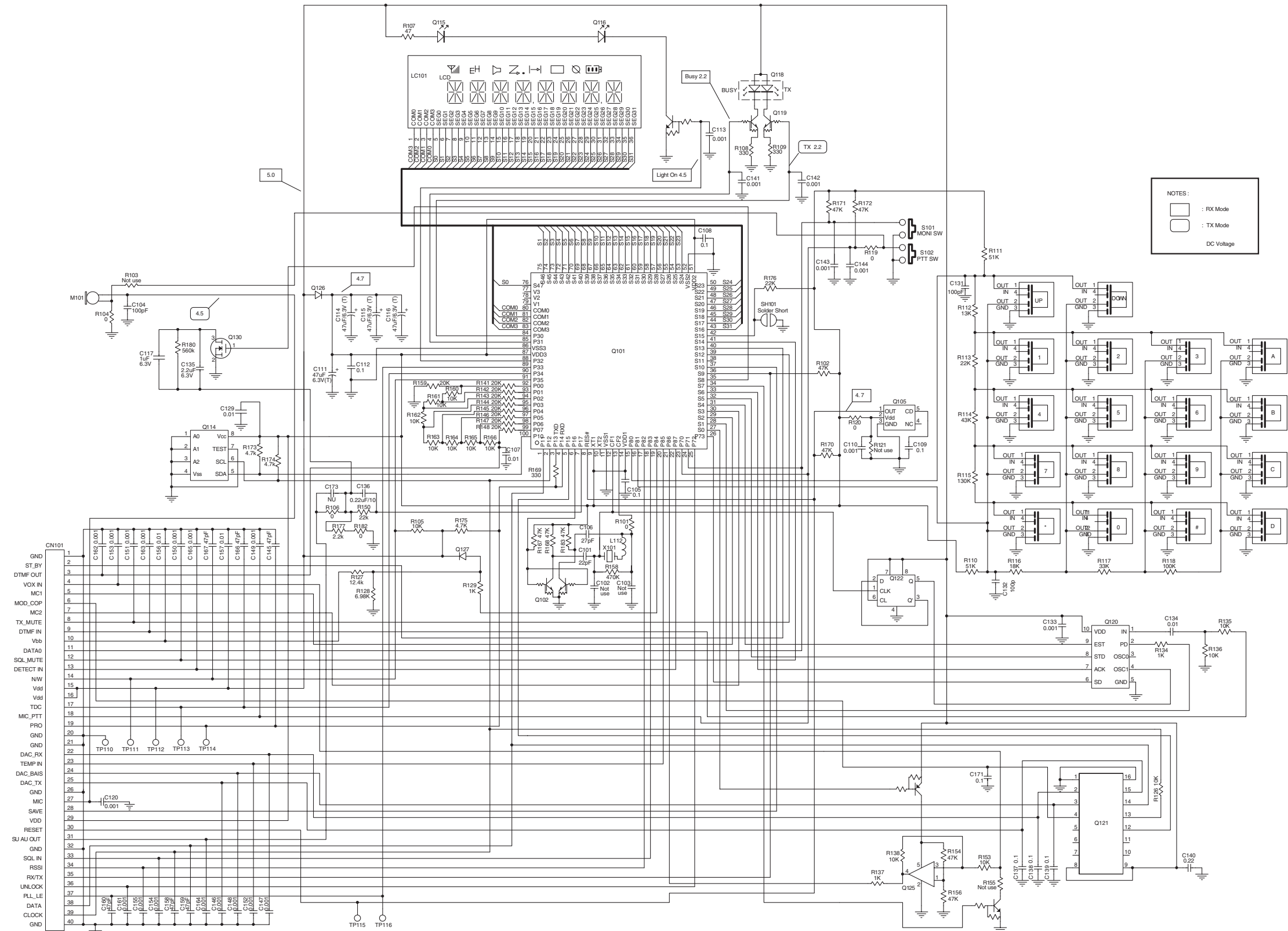

Figure 7-15. VHF 136-174 MHz Complete Controller Board Schematic Diagram



## VHF 136-174 MHz Radio Parts List (Controller Board)

Circuit Ref	Description	Vendor	Vendor Part Number	Motorola Equivalent Part Number
	<b>CAPACITOR</b>			
C101	22pF; 50V; +-5%	Murata	GRM39CH220J50PT	2113740F35
C102	NU			
C103	10pF; 50V; +-5%	Murata	GRM39CH100J50PT	N/A
C104	100pF; 50V; +-5%	Murata	GRM39CH101J50PT	2113740F51
C105	0.1uF; 16V; +-10%	Murata	GRM39B104K16PT	N/A
C106	27pF; 50V; +-5%	Murata	GRM39CH270J50PT	2113740F37
C107	0.01uF; 50V; +-10%	Murata	GRM39B103K50PT	N/A
C108	0.1uF; 16V; +-10%	Murata	GRM39B104K16PT	N/A
C109	0.1uF; 16V; +-10%	Murata	GRM39B104K16PT	N/A
C110	0.001uF; 50V; +-10%	Murata	GRM39B102K50PT	N/A
C111	47uF;6.3V;+-20%	NI-CHEMI	6MCM476MB2TER	N/A
C112	0.1uF; 16V; +-10%	Murata	GRM39B104K16PT	N/A
C113	0.001uF; 50V; +-10%	Murata	GRM39B102K50PT	N/A
C114	47uF;6.3V;+-20%	NI-CHEMI	6MCM476MB2TER	N/A
C115	47uF;6.3V;+-20%	NI-CHEMI	6MCM476MB2TER	N/A
C116	47uF;6.3V;+-20%	NI-CHEMI	6MCM476MB2TER	N/A
C117	1uF; 6.3V; +-10%	Murata	GRM39B105K6.3PT	2113928P04
C120	0.001uF; 50V; +-10%	Murata	GRM39B102K50PT	N/A
C129	0.01uF; 50V; +-10%	Murata	GRM39B103K50PT	N/A
C131	33pF; 50V; +-5%	Murata	GRM39CH330J50PT	2113740F39
C132	33pF; 50V; +-5%	Murata	GRM39CH330J50PT	2113740F39
C133	0.001uF; 50V; +-10%	Murata	GRM39B102K50PT	N/A
C134	0.01uF; 50V; +-10%	Murata	GRM39B103K50PT	N/A
C135	2.2pF; 6.3V	Murata	GRM40B225K6.3PT	N/A
C136	0.22uF; 10V; +-10%	Murata	GRM39B224K10PT	2113928G01
C137	0.1uF; 16V; +-10%	Murata	GRM39B104K16PT	N/A
C138	0.1uF; 16V; +-10%	Murata	GRM39B104K16PT	N/A
C139	0.1uF; 16V; +-10%	Murata	GRM39B104K16PT	N/A
C140	0.22uF; 10V; +-10%	Murata	GRM39B224K10PT	2113928G01
C141	0.001uF; 50V; +-10%	Murata	GRM39B102K50PT	N/A
C142	0.001uF; 50V; +-10%	Murata	GRM39B102K50PT	N/A
C143	0.001uF; 50V; +-10%	Murata	GRM39B102K50PT	N/A
C144	0.001uF; 50V; +-10%	Murata	GRM39B102K50PT	N/A
C145	47pF; 50V; +-5%	Murata	GRM39CH470J50PT	2113740F43
C146	0.001uF; 50V; +-10%	Murata	GRM39B102K50PT	N/A
C147	0.001uF; 50V; +-10%	Murata	GRM39B102K50PT	N/A
C148	0.001uF; 50V; +-10%	Murata	GRM39B102K50PT	N/A
C149	0.001uF; 50V; +-10%	Murata	GRM39B102K50PT	N/A
C150	0.001uF; 50V; +-10%	Murata	GRM39B102K50PT	N/A
C151	0.001uF; 50V; +-10%	Murata	GRM39B102K50PT	N/A
C152	0.001uF; 50V; +-10%	Murata	GRM39B102K50PT	N/A
C153	0.001uF; 50V; +-10%	Murata	GRM39B102K50PT	N/A
C154	0.001uF; 50V; +-10%	Murata	GRM39B102K50PT	N/A
C155	0.001uF; 50V; +-10%	Murata	GRM39B102K50PT	N/A
C156	0.01uF; 50V; +-10%	Murata	GRM39B103K50PT	N/A
C157	0.01uF; 50V; +-10%	Murata	GRM39B103K50PT	N/A
C158	47pF; 50V; +-5%	Murata	GRM39CH470J50PT	2113740F43
C159	47pF; 50V; +-5%	Murata	GRM39CH470J50PT	2113740F43

Circuit Ref	Description	Vendor	Vendor Part Number	Motorola Equivalent Part Number
C160	47pF; 50V; +-5%	Murata	GRM39CH470J50PT	2113740F43
C161	0.001uF; 50V; +-10%	Murata	GRM39B102K50PT	N/A
C162	0.001uF; 50V; +-10%	Murata	GRM39B102K50PT	N/A
C163	0.001uF; 50V; +-10%	Murata	GRM39B102K50PT	N/A
C164	0.001uF; 50V; +-10%	Murata	GRM39B102K50PT	N/A
C165	0.001uF; 50V; +-10%	Murata	GRM39B102K50PT	N/A
C166	47pF; 50V; +-5%	Murata	GRM39CH470J50PT	2113740F43
C167	47pF; 50V; +-5%	Murata	GRM39CH470J50PT	2113740F43
C171	0.1uF; 16V; +-10%	Murata	GRM39B104K16PT	N/A
C173	NU			
C174	NU			
C175	0.01uF; 50V; +-10%	Murata	GRM39B103K50PT	N/A
C176	NU			
C181	0.22uF; 10V; +-10%	Murata	GRM39B224K10PT	2113928G01
C182	0.22uF; 10V; +-10%	Murata	GRM39B224K10PT	2113928G01
C183	470pF; 50V; +-5%	Murata	GRM39CH471J50PT	N/A
C191	0.001uF; 50V; +-10%	Murata	GRM39B102K50PT	N/A
	<b>TRANSISTOR:</b>			
Q102	Dual NPN	Rohm	UMG2N TR	N/A
Q117	NPN	Rohm	DTC114EETL	N/A
Q119	Dual NPN	Rohm	UMH6N TR	4880439V02
Q123	PNP	Rohm	DTA144EETL	N/A
Q124	NU			
Q130	FET	Toshiba	SSM3K03FE-TE85L	N/A
	<b>DIODE:</b>			
Q126	Single	Rohm	RB521S-30 TE61	4805656W22
Q127	Diode	Rohm	1SS355 TE-17	4870360C15
Q131	Diode	Toshiba	1SS372-TE85L	N/A
	<b>INTEGRATED CIRCUIT:</b>			
Q105	IC,CPU Reset	Rico	RN5VD30CATR	DSIC076007
Q114	IC, EEPROM	Seiko El.	S-24C16AFJ-01	DSIC510003
Q120	IC, DTMF Decoder	Sanyo	LC73881M	DSIC092007
Q121	IC, D/A Converter	Fujitsu	MB88347PFV	DSIC042002
Q122	IC, D Flip-flop	Toshiba	TC7W74FU TE12L	DSIC013029
Q125	IC, Op-Amp	JRC	NJM2107F (TE1)	DSIC025016
	<b>LIGHT EMITTING DIODE:</b>			
Q115	LED	Citizen	CL-200G-C-TS	N/A
Q116	LED	Citizen	CL-200G-C-TS	N/A
Q118	Green/Red/Amber	Rohm	SML-020MLT T86NN	4804810T02
	<b>COIL:</b>			
L112	10uH	Taiyo Uden	LEM2520T100J	N/A
	<b>MISCELLANEOUS:</b>			
CN101	Connector	Matsushita	AXK5S40245J/P	DSCN097002
S101	Tact Switch	Motorola	Y39A33110FP	4080523Z01
S102	Tact Switch	Motorola	Y39A33110FP	4080523Z01
PB101	CONTROL-PCB	Shikibo	K001C802-12	N/A
	<b>MODULE:</b>			
Q101	CPU	Sanyo	LC87F72C8A	DSIC092009
LC101	LCD	Picvue	HT138ZAS	DSLCL170003
M101	Capacitor Microphone	Bosung	OB-22P44	DSMI505001

Circuit Ref	Description	Vendor	Vendor Part Number	Motorola Equivalent Part Number
	<b>CRYSTAL:</b>			
X101	Filter, 8.388608 MHz	Daishinkuu	AT-38	DSXT182001
	<b>RESISTOR:</b>			
R101	0 ohm; 0.1W; +-5%	Rohm	MCR03 EZHJ 000	0662057B47
R102	47 Kohm; 0.1W; +-5%	Rohm	MCR03 EZHJ 473	0662057A89
R103	NU			
R104	0 ohm; 0.1W; +-5%	Rohm	MCR03 EZHJ 000	0662057B47
R105	10 Kohm; 0.1W; +-5%	Rohm	MCR03 EZHJ 103	0662057A73
R106	0 ohm; 0.1W; +-5%	Rohm	MCR03 EZHJ 000	0662057B47
R107	47 ohm; 0.1W; +-5%	Rohm	MCR03 EZHJ 470	0662057A17
R108	330 ohm; 0.1W; +-5%	Rohm	MCR03 EZHJ 331	0662057A37
R109	330 ohm; 0.1W; +-5%	Rohm	MCR03 EZHJ 331	0662057A37
R110	51 Kohm; 0.1W; +-5%	Rohm	MCR03 EZHJ 513	0662057A90
R111	51 Kohm; 0.1W; +-5%	Rohm	MCR03 EZHJ 513	0662057A90
R112	13 Kohm; 0.1W; +-5%	Rohm	MCR03 EZHJ 133	0662057A76
R113	22 Kohm; 0.1W; +-5%	Rohm	MCR03 EZHJ 223	0662057A81
R114	43 Kohm; 0.1W; +-5%	Rohm	MCR03 EZHJ 433	0665027A88
R115	130 Kohm; 0.1W; +-5%	Rohm	MCR03 EZHJ 134	0662257B01
R116	18 Kohm; 0.1W; +-5%	Rohm	MCR03 EZHJ 183	0662057A79
R117	33 Kohm; 0.1W; +-5%	Rohm	MCR03 EZHJ 333	0662057A85
R118	100 Kohm; 0.1W; +-5%	Rohm	MCR03 EZHJ 104	0662057A97
R119	0 ohm; 0.1W; +-5%	Rohm	MCR03 EZHJ 000	0662057B47
R120	0 ohm; 0.1W; +-5%	Rohm	MCR03 EZHJ 000	0662057B47
R121	NU			
R126	10 Kohm; 0.1W; +-5%	Rohm	MCR03 EZHJ 103	0662057A73
R127	12.4 Kohm; 0.1W; +-1%	Rohm	MCR03 EZHF 1242	0662057P69
R128	6.98 Kohm; 0.1W; +-1%	Rohm	MCR03 EZHF 6981	0662057Y24
R129	1 Kohm; 0.1W; +-5%	Rohm	MCR03 EZHJ 102	0662057A49
R134	1 Kohm; 0.1W; +-5%	Rohm	MCR03 EZHJ 102	0662057A49
R135	10 Kohm; 0.1W; +-5%	Rohm	MCR03 EZHJ 103	0662057A73
R136	10 Kohm; 0.1W; +-5%	Rohm	MCR03 EZHJ 103	0662057A73
R137	1 Kohm; 0.1W; +-5%	Rohm	MCR03 EZHJ 102	0662057A49
R138	100 Kohm; 0.1W; +-5%	Rohm	MCR03 EZHJ 104	0662057A97
R141	20 Kohm; 0.1W; +-5%	Rohm	MCR03 EZHJ 203	0662057A80
R142	20 Kohm; 0.1W; +-5%	Rohm	MCR03 EZHJ 203	0662057A80
R143	20 Kohm; 0.1W; +-5%	Rohm	MCR03 EZHJ 203	0662057A80
R144	20 Kohm; 0.1W; +-5%	Rohm	MCR03 EZHJ 203	0662057A80
R145	20 Kohm; 0.1W; +-5%	Rohm	MCR03 EZHJ 203	0662057A80
R146	20 Kohm; 0.1W; +-5%	Rohm	MCR03 EZHJ 203	0662057A80
R147	20 Kohm; 0.1W; +-5%	Rohm	MCR03 EZHJ 203	0662057A80
R148	20 Kohm; 0.1W; +-5%	Rohm	MCR03 EZHJ 203	0662057A80
R150	22 Kohm; 0.1W; +-5%	Rohm	MCR03 EZHJ 223	0662057A81
R153	10 Kohm; 0.1W; +-5%	Rohm	MCR03 EZHJ 103	0662057A73
R154	47 Kohm; 0.1W; +-5%	Rohm	MCR03 EZHJ 473	0662057A89
R155	NU			
R156	47 Kohm; 0.1W; +-5%	Rohm	MCR03 EZHJ 473	0662057A89
R157	220 Kohm; 0.1W; +-5%	Rohm	MCR03 EZHJ 224	N/A
R158	470 Kohm; 0.1W; +-5%	Rohm	MCR03 EZHJ 474	0662057B14
R159	20 Kohm; 0.1W; +-5%	Rohm	MCR03 EZHJ 203	0662057A80
R160	10 Kohm; 0.1W; +-5%	Rohm	MCR03 EZHJ 103	0662057A73
R161	10 Kohm; 0.1W; +-5%	Rohm	MCR03 EZHJ 103	0662057A73

Circuit Ref	Description	Vendor	Vendor Part Number	Motorola Equivalent Part Number
R162	10 Kohm; 0.1W; +-5%	Rohm	MCR03 EZHJ 103	0662057A73
R163	10 Kohm; 0.1W; +-5%	Rohm	MCR03 EZHJ 103	0662057A73
R164	10 Kohm; 0.1W; +-5%	Rohm	MCR03 EZHJ 103	0662057A73
R165	10 Kohm; 0.1W; +-5%	Rohm	MCR03 EZHJ 103	0662057A73
R166	10 Kohm; 0.1W; +-5%	Rohm	MCR03 EZHJ 103	0662057A73
R167	47 Kohm; 0.1W; +-5%	Rohm	MCR03 EZHJ 473	0662057A89
R168	47 Kohm; 0.1W; +-5%	Rohm	MCR03 EZHJ 473	0662057A89
R169	330 ohm; 0.1W; +-5%	Rohm	MCR03 EZHJ 331	0662057A37
R170	47 Kohm; 0.1W; +-5%	Rohm	MCR03 EZHJ 473	0662057A89
R171	47 Kohm; 0.1W; +-5%	Rohm	MCR03 EZHJ 473	0662057A89
R172	47 Kohm; 0.1W; +-5%	Rohm	MCR03 EZHJ 473	0662057A89
R173	2.2 Kohm; 0.1W; +-5%	Rohm	MCR03 EZHJ 222	0662057A57
R174	2.2 Kohm; 0.1W; +-5%	Rohm	MCR03 EZHJ 222	0662057A57
R175	4.7 Kohm; 0.1W; +-5%	Rohm	MCR03 EZHJ 472	0662057A65
R176	22 Kohm; 0.1W; +-5%	Rohm	MCR03 EZHJ 223	0662057A81
R177	2.2 Kohm; 0.1W; +-5%	Rohm	MCR03 EZHJ 222	0662057A57
R180	560 Kohm; 0.1W; +-5%	Rohm	MCR03 EZHJ 564	N/A
R182	0 ohm; 0.1W; +-5%	Rohm	MCR10 EZHJ 000	N/A
R183	47 Kohm; 0.1W; +-5%	Rohm	MCR03 EZHJ 473	0662057A89
R184	10 Kohm; 0.1W; +-5%	Rohm	MCR03 EZHJ 103	0662057A73
R185	470 ohm; 0.1W; +-5%	Rohm	MCR03 EZHJ 471	0662057A41
R186	0 ohm; 0.1W; +-5%	Rohm	MCR03 EZHJ 000	0662057B47

## VHF 136-174 MHz Radio Parts List (RF Board)

Circuit Ref	Description	Vendor	Vendor Part Number	Motorola Equivalent Part Number
	<b>CAPACITOR</b>			
C201	0.01uF; 50V; +-10%	Murata	GRM39B103K50PT	N/A
C202	10uF; 6.3V; +-20%	NEC	TEMSVA0J106M8R	N/A
C203	1uF; 16V; +-20%	NEC	TESVA1C105M1-8R	N/A
C204	0.01uF; 50V; +-10%	Murata	GRM39B103K50PT	N/A
C205	0.01uF; 50V; +-10%	Murata	GRM39B103K50PT	N/A
C206	0.001uF; 50V; +-10%	Murata	GRM39B102K50PT	N/A
C207	10uF; 6.3V; +-20%	NEC	TEMSVA0J106M8R	N/A
C208	0.01uF; 50V; +-10%	Murata	GRM39B103K50PT	N/A
C209	0.001uF; 50V; +-10%	Murata	GRM39B102K50PT	N/A
C210	0.001uF; 50V; +-10%	Murata	GRM39B102K50PT	N/A
C211	0.001uF; 50V; +-10%	Murata	GRM39B102K50PT	N/A
C212	0.001uF; 50V; +-10%	Murata	GRM39B102K50PT	N/A
C213	10uF; 6.3V; +-20%	NEC	TEMSVA0J106M8R	N/A
C214	0.001uF; 50V; +-10%	Murata	GRM39B102K50PT	N/A
C215	2.2uF; 16V; +80% -20%	Murata	GRM40F225Z16PT	N/A
C217	0.1uF; 16V; +-10%	Murata	GRM39B104K16PT	N/A
C218	0.001uF; 50V; +-10%	Murata	GRM39B102K50PT	N/A
C301	10uF; 6.3V; +-20%	NEC	TEMSVA0J106M8R	N/A
C302	0.1uF; 16V; +-10%	Murata	GRM39B104K16PT	N/A
C303	0.0022uF; 50V; +-10%	Murata	GRM39B223K25PT	N/A
C304	10uF; 16V	NI-CHEMI	16MCM106MB2TER	N/A
C305	0.22uF; 10V; +-10%	Murata	GRM39B224K10PT	2113928G05
C308	0.001uF; 50V; +-10%	Murata	GRM39B102K50PT	N/A
C309	0.001uF; 50V; +-10%	Murata	GRM39B102K50PT	N/A
C310	0.001uF; 50V; +-10%	Murata	GRM39B102K50PT	N/A
C311	0.001uF; 50V; +-10%	Murata	GRM39B102K50PT	N/A
C312	10pF; 50V; +-0.5pF	Murata	GRM39CH100D50PT	2113740F27
C313	15pF; 50V; +-5%	Murata	GRM39CH150J50PT	2113740F31
C316	0.01uF; 50V; +-10%	Murata	GRM39B103K50PT	N/A
C317	47pF; 50V; +-5%	Murata	GRM39CH470J50PT	2113740F43
C318	47pF; 50V; +-5%	Murata	GRM39CH470J50PT	2113740F43
C319	47pF; 50V; +-5%	Murata	GRM39CH470J50PT	2113740F43
C323	2.2uF; 16V; +-20%	NEC	TEMSVA1C225M8R	N/A
C324	10uF; 16V	NI-CHEMI	16MCM106MB2TER	N/A
C325	NU			
C326	NU			
C327	NU			
C328	NU			
C335	10pF	Murata	TZV02Z100A110T00	N/A
C336	18pF; 50V; +-0.5pF	Murata	GRM39UJ180J50PT	N/A
C336	33pF; 50V; +-5%	Murata	GRM39UJ330J50PT	N/A
C336	33pF; 50V; +-5%	Murata	GRM39UJ330J50PT	N/A
C336	33pF; 50V; +-5%	Murata	GRM39UJ330J50PT	N/A
C336	33pF; 50V; +-5%	Murata	GRM39UJ330J50PT	N/A
C336	33pF; 50V; +-5%	Murata	GRM39UJ330J50PT	N/A
C337	8pF; 50V; +-0.5pF	Murata	GRM39CH080D50PT	N/A
C337	8pF; 50V; +-0.5pF	Murata	GRM39CH080D50PT	N/A
C337	8pF; 50V; +-0.5pF	Murata	GRM39UJ080D50PT	N/A
C337	8pF; 50V; +-0.5pF	Murata	GRM39UJ080D50PT	N/A

Circuit Ref	Description	Vendor	Vendor Part Number	Motorola Equivalent Part Number
C337	8pF; 50V; +-0.5pF	Murata	GRM39UJ080D50PT	N/A
C338	10pF; 50V; +-0.5pF	Murata	GRM39CH100D50PT	2113740F27
C338	10pF; 50V; +-0.5pF	Murata	GRM39CH100D50PT	2113740F27
C338	10pF; 50V; +-0.5pF	Murata	GRM39CH100D50PT	2113740F27
C338	10pF; 50V; +-0.5pF	Murata	GRM39UJ100D50PT	N/A
C338	10pF; 50V; +-0.5pF	Murata	GRM39UJ100D50PT	N/A
C339	0.001uF; 50V; +-10%	Murata	GRM39B102K50PT	N/A
C341	0.1uF; 16V; +-10%	Murata	GRM39B104K16PT	N/A
C343	10uF; 6.3V; +-20%	NEC	TEMSVA0J106M8R	N/A
C344	13pF; 50V; +-5%	Murata	GRM39CH130J50PT	2113740F30
C345	5pF; 50V; +-0.25pF	Murata	GRM39CH050C50PT	N/A
C346	0.1uF; 16V; +-10%	Murata	GRM39B104K16PT	N/A
C347	0.001uF; 50V; +-10%	Murata	GRM39B102K50PT	N/A
C348	NU			
C349	NU			
C350	56pF; 50V; +-5%	Murata	GRM39CH560J50PT	2113740F45
C351	68pF; 50V; +-5%	Murata	GRM39CH680J50PT	2113740F47
C352	1.5pF; 50V; +-0.25pF	Murata	GRM39CK1R5C50PT	N/A
C353	0.1uF; 16V; +-10%	Murata	GRM39B104K16PT	N/A
C354	1.5pF; 50V; +-0.25pF	Murata	GRM39CK1R5C50PT	N/A
C355	22pF; 50V; +-5%	Murata	GRM39CH220J50PT	2113740F35
C357	15pF; 50V; +-5%	Murata	GRM39CH150J50PT	2113740F31
C358	33pF; 50V; +-5%	Murata	GRM39CH330J50PT	2113740F39
C359	9pF; 50V; +-0.5pF	Murata	GRM39CH090D50PT	N/A
C360	NU			
C361	470pF; 50V; +-10%	Murata	GRM39B471K50PT	N/A
C362	2.2uF; 10V; +-20%	NEC	TESVA1A225M1-8R	N/A
C363	0.001uF; 50V; +-10%	Murata	GRM39B102K50PT	N/A
C366	10uF; 10V; +-20%	NEC	TESVA1A106M8R	N/A
C367	0.01uF; 50V; +-10%	Murata	GRM39B103K50PT	N/A
C368	1uF; 6.3V; +-10%	Murata	GRM39B105K6.3PT	2113928P04
C369	0.22uF; 35V; +-20%	NEC	TESVA1V224M8R	N/A
C371	1uF; 16V; +-20%	NEC	TESVA1C105M1-8R	N/A
C380	9pF; 50V; +-0.5pF	Murata	GRM39CH090D50PT	N/A
C381	NU			
C401	13pF; 50V; +-5%	Murata	GRM39CH130J50PT	2113740F30
C402	150pF; 50V; +-5%	Murata	GRM39CH151J50PT	2113740F55
C403	NU			
C404	20pF; 50V; +-5%	Murata	GRM39CH200J50PT	2113740F34
C405	NU			
C406	150pF; 50V; +-5%	Murata	GRM39CH151J50PT	2113740F55
C407	0.1uF; 16V; +-10%	Murata	GRM39B104K16PT	N/A
C408	120pF; 50V; +-5%	Murata	GRM39CH121J50PT	2113740F53
C409	100pF; 50V; +-5%	Murata	GRM39CH101J50PT	2113740F51
C410	330pF; 50V; +-10%	Murata	GRM39B331K50PT	N/A
C411	100pF; 50V; +-5%	Murata	GRM39CH101J50PT	2113740F51
C412	0.0022uF; 50V; +-10%	Murata	GRM39B223K25PT	N/A
C413	0.1uF; 16V; +-10%	Murata	GRM39B104K16PT	N/A
C414	330pF; 50V; +-10%	Murata	GRM39B331K50PT	N/A
C415	150pF; 50V; +-5%	Murata	GRM39CH151J50PT	2113740F55
C416	NU			

Circuit Ref	Description	Vendor	Vendor Part Number	Motorola Equivalent Part Number
C417	16pF; 50V; +-5%	Murata	GRM39CH160J50PT	2113740F32
C418	100pF; 50V; +-5%	Murata	GRM39CH101J50PT	2113740F51
C419	100pF; 50V; +-5%	Murata	GRM39CH101J50PT	2113740F51
C420	330pF; 50V; +-10%	Murata	GRM39B331K50PT	N/A
C421	NU			
C422	150pF; 50V; +-5%	Murata	GRM39CH151J50PT	2113740F55
C423	NU			
C424	10pF; 50V; +-0.5pF	Murata	GRM39CH100D50PT	2113740F27
C425	20pF; 50V; +-5%	Murata	GRM39CH200J50PT	2113740F34
C426	10pF; 50V; +-0.5pF	Murata	GRM39CH100D50PT	2113740F27
C427	9pF; 50V; +-0.5pF	Murata	GRM39CH090D50PT	N/A
C428	NU			
C429	0.0022uF; 50V; +-10%	Murata	GRM39B223K25PT	N/A
C430	10pF; 50V; +-0.5pF	Murata	GRM39CH100D50PT	2113740F27
C431	10pF; 50V; +-0.5pF	Murata	GRM39CH100D50PT	2113740F27
C432	82pF; 50V; +-5%	Murata	GRM39CH820J50PT	2113740F49
C433	24pF; 50V; +-5%	Murata	GRM39CH240J50PT	2113740F36
C434	NU			
C436	0.01uF; 50V; +-10%	Murata	GRM39B103K50PT	N/A
C437	56pF; 50V; +-5%	Murata	GRM39CH560J50PT	2113740F45
C438	120pF; 50V; +-5%	Murata	GRM39CH121J50PT	2113740F53
C439	7pF; 50V; +-0.5pF	Murata	GRM39CH070D50PT	N/A
C440	12pF; 50V; +-5%	Murata	GRM39CH120J50PT	2113740F29
C441	12pF; 50V; +-5%	Murata	GRM39CH120J50PT	2113740F29
C442	10pF; 50V; +-0.5pF	Murata	GRM39CH100D50PT	2113740F27
C443	24pF; 50V; +-5%	Murata	GRM39CH240J50PT	2113740F36
C444	47pF; 50V; +-5%	Murata	GRM39CH470J50PT	2113740F43
C445	12pF; 50V; +-5%	Murata	GRM39CH120J50PT	2113740F29
C446	9pF; 50V; +-0.5pF	Murata	GRM39CH090D50PT	N/A
C447	18pF; 50V; +-5%	Murata	GRM39CH180J50PT	2113740F33
C448	22pF; 50V; +-5%	Murata	GRM39CH220J50PT	2113740F35
C449	0.0022uF; 50V; +-10%	Murata	GRM39B223K25PT	N/A
C450	3pF; 50V; +-0.25pF	Murata	GRM39CH030C50PT	2103689A09
C451	56pF; 50V; +-5%	Murata	GRM39CH560J50PT	2113740F45
C452	150pF; 50V; +-5%	Murata	GRM39CH151J50PT	2113740F55
C453	1uF; 16V; +-10%	Murata	GRM40B105K16PT	N/A
C454	0.0033uF; 50V; +-10%	Murata	GRM39B332K50PT	2155169M15
C455	220pF; 50V; +-10%	Murata	GRM39B221K50PT	N/A
C456	22pF; 50V; +-5%	Murata	GRM39CH220J50PT	2113740F35
C457	330pF; 50V; +-10%	Murata	GRM39B331K50PT	N/A
C458	0.001uF; 50V; +-10%	Murata	GRM39B102K50PT	N/A
C459	0.0022uF; 50V; +-10%	Murata	GRM39B223K25PT	N/A
C460	27pF; 50V; +-5%	Murata	GRM39CH270J50PT	2113740F37
C461	0.0022uF; 50V; +-10%	Murata	GRM39B223K25PT	N/A
C462	330pF; 50V; +-10%	Murata	GRM39B331K50PT	N/A
C463	47pF; 50V; +-5%	Murata	GRM39CH470J50PT	2113740F43
C464	NU			
C465	NU			
C466	0.0022uF; 50V; +-10%	Murata	GRM39B223K25PT	N/A
C467	3pF; 50V; +-0.25pF	Murata	GRM39CH030C50PT	2103689A09
C468	22pF; 50V; +-5%	Murata	GRM39CH220J50PT	2113740F35

Circuit Ref	Description	Vendor	Vendor Part Number	Motorola Equivalent Part Number
C469	10pF; 50V; +-0.5pF	Murata	GRM39CH100D50PT	2113740F27
C470	5pF; 50V; +-0.25pF	Murata	GRM39CH050C50PT	N/A
C471	8pF; 50V; +-0.5pF	Murata	GRM39CH080D50PT	N/A
C472	56pF; 50V; +-5%	Murata	GRM39CH560J50PT	2113740F45
C473	0.001uF; 50V; +-10%	Murata	GRM39B102K50PT	N/A
C474	0.01uF; 50V; +-10%	Murata	GRM39B103K50PT	N/A
C475	10pF; 50V; +-0.5pF	Murata	GRM39CH100D50PT	2113740F27
C476	0.001uF; 50V; +-10%	Murata	GRM39B102K50PT	N/A
C477	0.001uF; 50V; +-10%	Murata	GRM39B102K50PT	N/A
C478	5pF; 50V; +-0.25pF	Murata	GRM39CH050C50PT	N/A
C479	0.001uF; 50V; +-10%	Murata	GRM39B102K50PT	N/A
C480	NU			
C481	0.001uF; 50V; +-10%	Murata	GRM39B102K50PT	N/A
C482	0.01uF; 50V; +-10%	Murata	GRM39B103K50PT	N/A
C483	0.001uF; 50V; +-10%	Murata	GRM39B102K50PT	N/A
C484	6.8uF; 6.3V; +-20%	NEC	TEMSVA0J685M8R	N/A
C485	2.2uF; 16V; +80% -20%	Murata	GRM40F225Z16PT	N/A
C486	33pF; 50V; +-5%	Murata	GRM39CH330J50PT	2113740F39
C487	NU			
C489	0.001uF; 50V; +-10%	Murata	GRM39B102K50PT	N/A
C490	100pF; 50V; +-5%	Murata	GRM39CH101J50PT	2113740F51
C493	0.01uF; 50V; +-10%	Murata	GRM39B103K50PT	N/A
C495	22pF; 50V; +-5%	Murata	GRM39CH220J50PT	2113740F35
C496	3pF; 50V; +-0.25pF	Murata	GRM39CH030C50PT	2103689A09
C501	0.001uF; 50V; +-10%	Murata	GRM39B102K50PT	N/A
C502	0.01uF; 50V; +-10%	Murata	GRM39B103K50PT	N/A
C503	NU			
C504	0.1uF; 16V; +-10%	Murata	GRM39B104K16PT	N/A
C505	100pF; 50V; +-5%	Murata	GRM39CH101J50PT	2113740F51
C506	0.1uF; 16V; +-10%	Murata	GRM39B104K16PT	N/A
C508	470pF; 50V; +-10%	Murata	GRM39B471K50PT	N/A
C509	0.001uF; 50V; +-10%	Murata	GRM39B102K50PT	N/A
C510	0.22uF; 10V; +-10%	Murata	GRM39B224K10PT	2113928G05
C511	0.1uF; 16V; +-10%	Murata	GRM39B104K16PT	N/A
C512	0.0022uF; 50V; +-10%	Murata	GRM39B222K50PT	N/A
C513	27pF; 50V; +-5%	Murata	GRM39CH270J50PT	2113740F37
C514	0.01uF; 50V; +-10%	Murata	GRM39B103K50PT	N/A
C515	0.01uF; 16V; +-2%	Panasonic	ECHU1C103GX5	N/A
C516	0.01uF; 16V; +-2%	Panasonic	ECHU1C103GX5	N/A
C517	0.01uF; 16V; +-2%	Panasonic	ECHU1C103GX5	N/A
C518	0.01uF; 16V; +-2%	Panasonic	ECHU1C103GX5	N/A
C519	0.01uF; 50V; +-10%	Murata	GRM39B103K50PT	N/A
C520	0.01uF; 16V; +-2%	Panasonic	ECHU1C103GX5	N/A
C521	0.01uF; 16V; +-2%	Panasonic	ECHU1C103GX5	N/A
C522	0.01uF; 16V; +-2%	Panasonic	ECHU1C103GX5	N/A
C523	0.22uF; 10V; +-10%	Murata	GRM39B224K10PT	2113928G05
C524	0.068uF; 16V; +-10%	Murata	GRM39B683K16PT	N/A
C525	33pF; 50V; +-5%	Murata	GRM39CH330J50PT	2113740F39
C526	39pF; 50V; +-5%	Murata	GRM39CH390J50PT	2113740F41
C527	0.001uF; 50V; +-10%	Murata	GRM39B102K50PT	N/A
C528	1uF; 6.3V; +-10%	Murata	GRM39B105K6.3PT	2113928P04



Circuit Ref	Description	Vendor	Vendor Part Number	Motorola Equivalent Part Number
C529	0.1uF; 16V; +-10%	Murata	GRM39B104K16PT	N/A
C530	0.1uF; 16V; +-10%	Murata	GRM39B104K16PT	N/A
C531	220pF; 50V; +-10%	Murata	GRM39B221K50PT	N/A
C532	220pF; 50V; +-10%	Murata	GRM39B221K50PT	N/A
C533	22pF; 50V; +-5%	Murata	GRM39CH220J50PT	2113740F35
C534	2.2uF; 10V; +-20%	NEC	TESVA1A225M1-8R	N/A
C535	0.027uF; 25v; +-10%	Murata	GRM39B273K25PT	2155169N29
C536	0.047uF; 16V; +-10%	Murata	GRM39B473K16PT	N/A
C537	0.0027uF; 50V; +-10%	Murata	GRM39B272K50PT	N/A
C538	0.01uF; 50V; +-10%	Murata	GRM39B103K50PT	N/A
C539	0.039uF; 16v; +-10%	Murata	GRM39B393K16PT	N/A
C540	0.015uF; 50V; +-10%	Murata	GRM39B152K50PT	2113932E03
C541	0.1uF; 16V; +-10%	Murata	GRM39B104K16PT	N/A
C542	390pF; 50V; +-10%	Murata	GRM39B391K50PT	2113741F15
C543	0.0047uF; 50V; +-10%	Murata	GRM39B472K50PT	N/A
C544	0.22uF; 10V; +-10%	Murata	GRM39B224K10PT	2113928G05
C545	33uF; 6.3V; +-20%	NEC	TEMSVB20J336M8R	N/A
C546	0.1uF; 16V; +-10%	Murata	GRM39B104K16PT	N/A
C547	0.1uF; 16V; +-10%	Murata	GRM39B104K16PT	N/A
C550	0.01uF; 16V; +-2%	Panasonic	ECHU1C103GX5	N/A
C551	0.01uF; 16V; +-2%	Panasonic	ECHU1C103GX5	N/A
C601	330pF; 50V; +-5%	Murata	GRM39CH331J50PT	N/A
C602	0.0033uF; 50V; +-10%	Murata	GRM39B332K50PT	2155169M15
C603	82pF; 50V; +-5%	Murata	GRM39CH820J50PT	2113740F49
C604	0.0012uF; 50V; +-10%	Murata	GRM39B122K50PT	N/A
C605	680pF; 50V; +10%	Murata	GRM39B681K50PT	N/A
C606	0.047uF; 16V; +-10%	Murata	GRM39B473K16PT	N/A
C607	0.1uF; 16V; +-10%	Murata	GRM39B104K16PT	N/A
C608	NU			
C612	10pF; 50V; +-0.5pF	Murata	GRM39CH100D50PT	2113740F27
C615	0.01uF; 50V; +-10%	Murata	GRM39B103K50PT	N/A
C616	0.027uF; 25v; +-10%	Murata	GRM39B273K25PT	2155169N29
C617	0.0047uF; 50V; +-10%	Murata	GRM39B472K50PT	N/A
C618	82pF; 50V; +-5%	Murata	GRM39CH820J50PT	2113740F49
C619	0.1uF; 16V; +-10%	Murata	GRM39B104K16PT	N/A
C620	NU			
C621	0.001uF; 50V; +-10%	Murata	GRM39B102K50PT	N/A
C622	0.001uF; 50V; +-10%	Murata	GRM39B102K50PT	N/A
C623	0.01uF; 50V; +-10%	Murata	GRM39B103K50PT	N/A
C624	220pF; 50V; +-10%	Murata	GRM39B221K50PT	N/A
C625	4.7uF; 6.3V; +-20%	NEC	TEMSVA0J475M8R	N/A
C626	10uF; 6.3V; +-20%	NEC	TEMSVA0J106M8R	N/A
C627	470pF; 50V; +-10%	Murata	GRM39B471K50PT	N/A
C628	1uF; 16V; +-20%	NEC	TESVA1C105M1-8R	N/A
C629	1uF; 6.3V; +-10%	Murata	GRM39B105K6.3PT	2113928P04
C630	0.01uF; 50V; +-10%	Murata	GRM39B103K50PT	N/A
C631	0.0082uF; 50V; +-10%	Murata	GRM39B822K50PT	N/A
C632	68pF; 50V; +-5%	Murata	GRM39CH680J50PT	2113740F47
C633	0.01uF; 50V; +-10%	Murata	GRM39B103K50PT	N/A
C634	0.0018uF; 50V; +-10%	Murata	GRM39B182K50PT	2155116E54
C635	0.1uF; 16V; +-10%	Murata	GRM39B104K16PT	N/A

Circuit Ref	Description	Vendor	Vendor Part Number	Motorola Equivalent Part Number
C636	100pF; 50V; +-5%	Murata	GRM39CH101J50PT	2113740F51
C637	2.2uF; 16V; +80% -20%	Murata	GRM40F225Z16PT	N/A
C638	4.7uF; 6.3V; +-20%	NEC	TEMSVA0J475M8R	N/A
C639	27pF; 50V; +-5%	Murata	GRM39CH270J50PT	2113740F37
C641	0.22uF; 10V; +-10%	Murata	GRM39B224K10PT	2113928G05
C642	0.015uF; 50V; +-10%	Murata	GRM39B152K50PT	2113932E03
C643	NU			
C643	1uF; 6.3V; +-10%	Murata	GRM39B105K6.3PT	2113928P04
C701	0.001uF; 50V; +-10%	Murata	GRM39B102K50PT	N/A
C702	0.001uF; 50V; +-10%	Murata	GRM39B102K50PT	N/A
C703	0.22uF; 10V; +-10%	Murata	GRM39B224K10PT	2113928G05
C704	4.7uF; 6.3V; +-20%	NEC	TEMSVA0J475M8R	N/A
C705	2.2uF; 16V; +80% -20%	Murata	GRM40F225Z16PT	N/A
C706	0.1uF; 16V; +-10%	Murata	GRM39B104K16PT	N/A
C707	0.001uF; 50V; +-10%	Murata	GRM39B102K50PT	N/A
C708	0.001uF; 50V; +-10%	Murata	GRM39B102K50PT	N/A
C709	10uF; 6.3V; +-20%	NEC	TEMSVA0J106M8R	N/A
C710	0.1uF; 16V; +-10%	Murata	GRM39B104K16PT	N/A
C711	0.1uF; 16V; +-10%	Murata	GRM39B104K16PT	N/A
C713	0.1uF; 16V; +-10%	Murata	GRM39B104K16PT	N/A
C714	100pF; 50V; +-5%	Murata	GRM39CH101J50PT	2113740F51
C715	100pF; 50V; +-5%	Murata	GRM39CH101J50PT	2113740F51
C716	100pF; 50V; +-5%	Murata	GRM39CH101J50PT	2113740F51
C717	100pF; 50V; +-5%	Murata	GRM39CH101J50PT	2113740F51
C718	100pF; 50V; +-5%	Murata	GRM39CH101J50PT	2113740F51
C719	220pF; 50V; +-5%	Murata	GRM39CH221J50PT	N/A
C720	0.001uF; 50V; +-10%	Murata	GRM39B102K50PT	N/A
C721	0.1uF; 16V; +-10%	Murata	GRM39B104K16PT	N/A
	<b>TRANSISTOR:</b>			
Q201	PNP	NEC	2SB798-T1 DK	N/A
Q202	Digital transistor	Rohm	UMW1N TL	N/A
Q206	PNP	Rohm	DTA123YETL	N/A
Q207	Digital transistor	Rohm	UMW1N TL	N/A
Q208	PNP	Rohm	DTA114EETL	4808317Y01
Q209	PNP	Rohm	DTA144EETL	N/A
Q210	PNP	Toshiba	2SA1362-GR TE85L	N/A
Q211	PNP	Rohm	DTA123YETL	N/A
Q308	NPN	Toshiba	2SC5086-Y TE85L	N/A
Q309	FET	NEC	2SJ243-T1	N/A
Q310	Digital transistor	Rohm	UMC4N TR	N/A
Q314	PNP	Toshiba	2SA1362-GR TE85L	N/A
Q315	NPN	Toshiba	2SC4116-GR TE85L	N/A
Q320	Transistor	Rohm	UMZ2N-TR	4809939C06
Q324	NPN	NEC	2SC4226-T1 R24	N/A
Q325	NPN	NEC	2SC4226-T1 R24	N/A
Q330	NPN	Toshiba	2SC4116-GR TE85L	N/A
Q331	NPN	Toshiba	2SC4116-GR TE85L	N/A
Q404	NPN	Toshiba	2SC5086-Y TE85L	N/A
Q408	NPN	Toshiba	2SC5086-Y TE85L	N/A
Q411	FET	Toshiba	2SK3476	DSTR013027
Q412	FET	Toshiba	2SK3475	DSTR013026

Circuit Ref	Description	Vendor	Vendor Part Number	Motorola Equivalent Part Number
Q413	NPN	NEC	2SC3356-T1B R24	N/A
Q414	NPN	Toshiba	2SC5086-Y TE85L	N/A
Q416	NPN	Toshiba	2SC5086-Y TE85L	N/A
Q417	PNP	Rohm	DTA144EETL	N/A
Q418	PNP	Rohm	DTA144EETL	N/A
Q501	Digital transistor	Rohm	UMC4N TR	N/A
Q503	FET	Toshiba	2SJ144Y-TE85L	N/A
Q504	PNP	Rohm	DTA144EETL	N/A
Q509	PNP	Rohm	DTA144EETL	N/A
Q601	PNP	Rohm	DTA144EETL	N/A
Q605	PNP	Rohm	DTA144EETL	N/A
Q608	PNP	Rohm	DTA144EETL	N/A
Q609	Digital transistor	Rohm	UMG2N TR	N/A
Q613	PNP	Rohm	DTA144EETL	N/A
Q616	FET	Toshiba	SSM3K03FE-TE85L	N/A
Q701	PNP	Rohm	DTA144EETL	N/A
Q703	PNP	Rohm	DTA144EETL	N/A
Q704	PNP	Toshiba	2SA1362-GR TE85L	N/A
Q707	PNP	Toshiba	2SA1313-Y TE85L	N/A
Q708	PNP	Toshiba	2SA1362-GR TE85L	N/A
Q709	PNP	Toshiba	2SA1362-GR TE85L	N/A
	<b>DIODE:</b>			
Q203	Single	Rohm	1SR154-400 TE25	4842006M02
Q311	Varactor	Toshiba	1SV217-TPH3	N/A
Q316	Zener ;7.6V	Rohm	UDZ S 7.5B TE-17	N/A
Q319	Single	Rohm	1SS355 TE-17	4870360C15
Q322	Varactor	Toshiba	1SV217-TPH3	N/A
Q326	Varactor	Toshiba	1SV217-TPH3	N/A
Q329	Varactor	Toshiba	1SV217-TPH3	N/A
Q401	Varactor	Toshiba	1SV217-TPH3	N/A
Q403	Dual Varactor	Toshiba	1SS362-TE85L	N/A
Q405	Varactor	Toshiba	1SV217-TPH3	N/A
Q407	Diode	HP	HSMS-2817	N/A
Q409	Single	Hitachi	HVU131TRF	N/A
Q410	Diode	MA/COM	MA4PH262	N/A
Q415	Single	Hitachi	HSC277TRF	N/A
Q507	Dual	Rohm	DAN235ETL	N/A
Q508	Dual	Rohm	DAN235ETL	N/A
Q511	Diode	Rohm	RB521S-30 TE61	N/A
Q607	NU			
Q614	Dual Varactor	Toshiba	1SS362-TE85L	N/A
Q615	Dual	Rohm	DAN222TL	4809606E02
Q705	Single	Rohm	1SR154-400 TE25	4842006M02
Q706	Zener;6.9V	Rohm	UDZ S 6.8B TE-17	4842006M03
Q710	Zener;20.39V	Rohm	UDZ S 20B TE-17	N/A
Q711	Single	Rohm	1SR154-400 TE25	4842006M02
Q712	Single	Rohm	1SS355 TE-17	4870360C15
	<b>INTEGRATED CIRCUIT:</b>			
Q204	IC	TOREX	XC62HR5002PR	DSIC510004
Q301	IC, DC-DC Converter	Toko	TK11816M	DSIC011011
Q323	IC, PLL	Fujitsu	MB15A02PFV1-ER	DSIC042003

Circuit Ref	Description	Vendor	Vendor Part Number	Motorola Equivalent Part Number
Q419	IC, Op-Amp	JRC	NJM2904V(TE1)	DSIC510001
Q502	IC, Op-Amp	JRC	NJM324V(TE1)	DSIC510002
Q505	IC, Op-Amp	JRC	NJM324V(TE1)	DSIC510002
Q506	IC	Toshiba	TA31136FN-TP1	DSIC013007
Q510	IC, Op-Amp	JRC	NJM2107F (TE1)	DSIC025016
Q602	IC, Op-Amp	JRC	NJM324V(TE1)	DSIC510002
Q610	IC, Op-Amp	JRC	NJM324V(TE1)	DSIC510002
Q702	IC	Philips	TDA8541T/N1	DSIC174004
	<b>COIL:</b>			
L301	100nH	Toko	LL1608-FSR10J	2413926N24
L302	100nH	Sagami Elec	C2012C-R10J	N/A
L303	1000uH	TDK	NL453232T-102J	N/A
L305	47nH	Sagami Elec	C2012C-47NG	2413923B12
L306	1uH	Sagami Elec	C2520C-1R0J	2462587N68
L307	Chip Emifil	Murata	BLM21A121SPT	2480067M02
L312	1uH	Toko	FSLM2520-1R0J	2485601J13
L313	47nH	Sagami Elec	C2012C-47NG	2413923B12
L314	56nH	Sagami Elec	C2012C-56NG	2413923B18
L315	47nH	Sagami Elec	C2012C-47NG	2413923B12
L317	47nH	Sagami Elec	C2012C-47NG	2413923B12
L318	1uH	Sagami Elec	C2520C-1R0J	2462587N68
L401	12nH	Sagami Elec.	C2012C-12NJ	2462587V23
L402	12nH	Sagami Elec.	C2012C-12NJ	2462587V23
L403	470nH	Toko	FSLM2520-R47K	2485602J33
L404	12nH	Sagami Elec.	C2012C-12NJ	2462587V23
L405	12nH	Sagami Elec.	C2012C-12NJ	2462587V23
L406	Airwound Coil	Uchida/Letest	E2-0.30-1.0-4TL	4880048M03
L407	Coil	Latest	SMD-0314A	N/A
L408	Coil	Latest	SMD-0314A	N/A
L409	33nH	Toko	LL2012-FH33NJ	2413926N17
L410	150nH	Sagami Elec	C2012C-R15J	2462587V36
L411	470nH	Toko	FSLM2520-R47K	2485602J33
L413	Airwound Coil	Uchida/Letest	E2-0.40-0.9-3TL	N/A
L414	Airwound Coil	Uchida/Letest	E2-0.30-1.7-6TL	N/A
L415	Airwound Coil	Uchida/Letest	E2-0.30-1.7-5TL	N/A
L416	Airwound Coil	Uchida/Letest	E2-0.30-1.7-5TL	N/A
L417	1uH	Toko	FSLM2520-1R0J	2485601J13
L418	Airwound Coil	Uchida/Letest	E2-0.30-1.0-7TL	N/A
L419	Airwound Coil	Uchida/Letest	E2-0.40-0.9-3TL	N/A
L420	Airwound Coil	Uchida/Letest	E2-0.40-1.0-5TL	N/A
L421	39nH	Sagami Elec	C2012C-39NJ	2462587V29
L422	Airwound Coil	Uchida/Letest	E2-0.40-0.9-3TL	N/A
L423	Airwound Coil	Uchida/Letest	E2-0.30-1.0-6TL	N/A
L424	Airwound Coil	Uchida/Letest	E2-0.30-1.0-5TL	N/A
L425	68nH	Sagami Elec	C2012C-68NJ	2462587V32
L426	Airwound Coil	Uchida/Letest	E2-0.30-1.0-4TL	4880048M03
L427	100nH	Toko	LL1608-FSR10J	2413926N24
L428	100nH	Toko	LL1608-FSR10J	2413926N24
L429	Chip Beads	TDK	ZBFS5105-PT	N/A
L430	100nH	Toko	LL1608-FSR10J	2413926N24
L431	2.2uH	TDK	MLF1608A2R2KT	N/A

Circuit Ref	Description	Vendor	Vendor Part Number	Motorola Equivalent Part Number
L501	1uH	TDK	MLF1608A1R0KT	N/A
L702	390nH	Sagami Elec	C2012C-R39J	2462587V41
	<b>JACK:</b>			
CN201	Connector contact Battery	Motorola	09D86237A	0986237A01
CN701	Connector	Matsushita	AXK6S40545J/P	DSCN097003
J401	Antenna Jack	Motorola	02D80689C	0280689C01
J701	Audio Jack	Motorola	09R80683Z	0980683Z01
	<b>DISCRIMINATOR</b>			
CD501	Discriminator	Samsung	IFD0455C24E03	N/A
	<b>CERAMIC FILTER:</b>			
F501	Ceramic filter	Toko	BLFYM455D	N/A
F502	Ceramic filter	Toko	ALFYM455G	N/A
	<b>CRYSTAL</b>			
F401	NU			
F402	Filter , 45.1 MHz	HERTZ	45N12A5 (45.1MHz) UM-5J-SMD	DSXF137006
X301	Crystal	Nikko Denshi	TOP-B 14.4MHz RANK-2	DSXT181002
X501	Crystal	Nikko Denshi	TOP-B 44.645MHz +- 10ppm, +-4ppm	DSXT181006
	<b>MISCELLANEOUS</b>			
J702	Connector	Molex	53047-0210	DSCN075035
P701	SP WIRE Assembly	EU-connector	WC-013	N/A
SW201	Potentiometers	TOCOS	TP76N17N A10Kohm 10SK	DSVR010008
SP701	Speaker	Orient sound	K028NA	N/A
PB201	RF-VHF-PCB	Shikibo	K001C801-11	N/A
	<b>RESISTOR:</b>			
R201	10 Kohm; 0.1W; +-5%	Rohm	MCR03 EZHJ 103	0662057A73
R202	2.2 Kohm; 0.1W; +-5%	Rohm	MCR03 EZHJ 222	0662057A57
R203	4.7 Kohm; 0.1W; +-5%	Rohm	MCR03 EZHJ 472	0662057A65
R204	4.7 Kohm; 0.1W; +-5%	Rohm	MCR03 EZHJ 472	0662057A65
R205	50K ohm	Hokuriku	NSM3503J400J	N/A
R206	NU			
R207	10 Kohm; 0.1W; +-5%	Rohm	MCR03 EZHJ 103	0662057A73
R208	4.7 Kohm; 0.1W; +-5%	Rohm	MCR03 EZHJ 472	0662057A65
R209	10 ohm; 0.1W; +-5%	Rohm	MCR03 EZHJ 100	0662057A01
R210	22 ohm; 0.1W; +-5%	Rohm	MCR03 EZHJ 220	0662057A09
R211	10 Kohm; 0.1W; +-5%	Rohm	MCR03 EZHJ 103	0662057A73
R212	100 ohm; 0.1W; +-5%	Rohm	MCR03 EZHJ 101	0662057A25
R301	1 Kohm; 0.1W; +-5%	Rohm	MCR03 EZHJ 102	0662057A49
R302	220 ohm; 0.1W; +-5%	Rohm	MCR03 EZHJ 221	0662057A33
R310	100 ohm; 0.1W; +-5%	Rohm	MCR03 EZHJ 101	0662057A25
R311	15 Kohm; 0.1W; +-5%	Rohm	MCR03 EZHJ 153	0662057A77
R312	220 ohm; 0.1W; +-5%	Rohm	MCR03 EZHJ 221	0662057A33
R313	100 Kohm; 0.1W; +-5%	Rohm	MCR03 EZHJ 104	0662057A97
R314	0 ohm; 0.1W; +-5%	Rohm	MCR03 EZHJ 000	0662057B47
R315	2.7 Kohm; 0.1W; +-5%	Rohm	MCR03 EZHJ 272	0662057A59
R316	1.5 Kohm; 0.1W; +-5%	Rohm	MCR03 EZHJ 152	0662057A53
R317	2.2 Kohm; 0.1W; +-5%	Rohm	MCR03 EZHJ 222	0662057A57
R318	10 Kohm; 0.1W; +-5%	Rohm	MCR03 EZHJ 103	0662057A73

Circuit Ref	Description	Vendor	Vendor Part Number	Motorola Equivalent Part Number
R319	10 Kohm; 0.1W; +-5%	Rohm	MCR03 EZHJ 103	0662057A73
R320	1.5 Kohm; 0.1W; +-5%	Rohm	MCR03 EZHJ 152	0662057A53
R321	6.8 Kohm; 0.1W; +-5%	Rohm	MCR03 EZHJ 682	0662057A69
R322	10 Kohm; 0.1W; +-5%	Rohm	MCR03 EZHJ 103	0662057A73
R323	Chip network resistor	Hokuriku	CRA168-472J	DSRA508001
R325	10 Kohm; 0.1W; +-5%	Rohm	MCR03 EZHJ 103	0662057A73
R327	100 Kohm; 0.1W; +-5%	Rohm	MCR03 EZHJ 104	0662057A97
R329	220 Kohm; 0.1W; +-1%	Rohm	MCR03 EZHF 2203	N/A
R330	10K ohm	Murata	NTH5G16P39A103K07 TH	N/A
R332	100 Kohm; 0.1W; +-1%	Rohm	MCR03 EZHF 1003	0662057P95
R333	100 Kohm; 0.1W; +-5%	Rohm	MCR03 EZHJ 104	0662057A97
R335	100 Kohm; 0.1W; +-5%	Rohm	MCR03 EZHJ 104	0662057A97
R336	100 Kohm; 0.1W; +-5%	Rohm	MCR03 EZHJ 104	0662057A97
R337	150 Kohm; 0.1W; +-1%	Rohm	MCR03 EZHF 1503	0662057P97
R338	220 ohm; 0.1W; +-5%	Rohm	MCR03 EZHJ 221	0662057A33
R339	15 ohm; 0.1W; +-5%	Rohm	MCR03 EZHJ 150	0662057A05
R340	22 Kohm; 0.1W; +-5%	Rohm	MCR03 EZHJ 223	0662057A81
R341	NU			
R342	100 Kohm; 0.1W; +-5%	Rohm	MCR03 EZHJ 104	0662057A97
R343	2.2 Kohm; 0.1W; +-5%	Rohm	MCR03 EZHJ 222	0662057A57
R346	10 Kohm; 0.1W; +-5%	Rohm	MCR03 EZHJ 103	0662057A73
R347	10 Kohm; 0.1W; +-5%	Rohm	MCR03 EZHJ 103	0662057A73
R349	1 Kohm; 0.1W; +-5%	Rohm	MCR03 EZHJ 102	0662057A49
R350	4.7 Kohm; 0.1W; +-5%	Rohm	MCR03 EZHJ 472	0662057A65
R355	NU			
R356	4.7 Kohm; 0.1W; +-5%	Rohm	MCR03 EZHJ 472	0662057A65
R357	10 ohm; 0.1W; +-5%	Rohm	MCR03 EZHJ 100	0662057A01
R358	47 ohm; 0.1W; +-5%	Rohm	MCR03 EZHJ 470	0662057A17
R359	4.7 Kohm; 0.1W; +-5%	Rohm	MCR03 EZHJ 472	0662057A65
R361	22 Kohm; 0.1W; +-5%	Rohm	MCR03 EZHJ 223	0662057A81
R362	22 Kohm; 0.1W; +-5%	Rohm	MCR03 EZHJ 223	0662057A81
R363	470 ohm; 0.1W; +-5%	Rohm	MCR03 EZHJ 471	0662057A41
R364	2.7 Kohm; 0.1W; +-5%	Rohm	MCR03 EZHJ 272	0662057A59
R365	470 ohm; 0.1W; +-5%	Rohm	MCR03 EZHJ 471	0662057A41
R366	470 ohm; 0.1W; +-5%	Rohm	MCR03 EZHJ 471	0662057A41
R401	100 Kohm; 0.1W; +-5%	Rohm	MCR03 EZHJ 104	0662057A97
R402	5.6 Kohm; 0.1W; +-5%	Rohm	MCR03 EZHJ 562	0662057A67
R403	3.3 Kohm; 0.1W; +-5%	Rohm	MCR03 EZHJ 332	0662057A61
R404	10 Kohm; 0.1W; +-5%	Rohm	MCR03 EZHJ 103	0662057A73
R405	2.2 ohm; 0.1W; +-5%	Rohm	MCR03 EZHJ 2R2	0662057W09
R406	0 ohm; 0.1W; +-5%	Rohm	MCR03 EZHJ 000	0662057B47
R407	10 ohm; 0.1W; +-5%	Rohm	MCR03 EZHJ 100	0662057A01
R408	1 Kohm; 0.1W; +-5%	Rohm	MCR03 EZHJ 102	0662057A49
R409	390 ohm; 0.1W; +-5%	Rohm	MCR03 EZHJ 391	0662057A39
R410	100 Kohm; 0.1W; +-5%	Rohm	MCR03 EZHJ 104	0662057A97
R411	NU			
R412	NU			
R413	56 ohm; 0.1W; +-5%	Rohm	MCR03 EZHJ 560	0662057A19
R414	0 ohm; 0.1W; +-5%	Rohm	MCR03 EZHJ 000	0662057B47
R415	150 Kohm; 0.1W; +-5%	Rohm	MCR03 EZHJ 154	0662057B02

Circuit Ref	Description	Vendor	Vendor Part Number	Motorola Equivalent Part Number
R416	1 Kohm; 0.1W; +-5%	Rohm	MCR03 EZHJ 102	0662057A49
R418	39 ohm;0.1W;+-5%	Rohm	MCR03 EZHJ 390	0662057A15
R419	220 ohm; 0.1W; +-5%	Rohm	MCR03 EZHJ 221	0662057A33
R420	100 ohm; 0.1W; +-5%	Rohm	MCR03 EZHJ 101	0662057A25
R421	120 ohm; 0.1W; +-5%	Rohm	MCR03 EZHJ 121	0662057A27
R422	39 ohm;0.1W;+-5%	Rohm	MCR03 EZHJ 390	0662057A15
R423	22 Kohm; 0.1W; +-5%	Rohm	MCR03 EZHJ 223	0662057A81
R424	12 Kohm; 0.1W; +-5%	Rohm	MCR03 EZHJ 123	0662057A51
R425	NU			
R426	100 ohm; 0.1W; +-5%	Rohm	MCR03 EZHJ 101	0662057A25
R427	12 Kohm; 0.1W; +-5%	Rohm	MCR03 EZHJ 123	0662057A51
R428	100 Kohm; 0.1W; +-5%	Rohm	MCR03 EZHJ 104	0662057A97
R429	470 ohm; 0.1W; +-5%	Rohm	MCR03 EZHJ 471	0662057A41
R430	100 ohm; 0.1W; +-5%	Rohm	MCR03 EZHJ 101	0662057A25
R431	15 Kohm; 0.1W; +-5%	Rohm	MCR03 EZHJ 153	0662057A77
R432	220 ohm; 0.1W; +-5%	Rohm	MCR03 EZHJ 221	0662057A33
R433	10 Kohm; 0.1W; +-5%	Rohm	MCR03 EZHJ 103	0662057A73
R434	10 ohm; 0.1W; +-5%	Rohm	MCR03 EZHJ 100	0662057A01
R435	10 Kohm; 0.1W; +-5%	Rohm	MCR03 EZHJ 103	0662057A73
R436	4.7 Kohm; 0.1W; +-5%	Rohm	MCR03 EZHJ 472	0662057A65
R437	680 ohm; 0.1W; +-5%	Rohm	MCR03 EZHJ 681	0662057A45
R438	4.7 ohm; 0.1W; +-5%	Rohm	MCR03 EZHJ 4R7	0662057W17
R439	15 Kohm; 0.1W; +-5%	Rohm	MCR03 EZHJ 153	0662057A77
R440	4.7 Kohm; 0.1W; +-5%	Rohm	MCR03 EZHJ 472	0662057A65
R441	1 Kohm; 0.1W; +-5%	Rohm	MCR03 EZHJ 102	0662057A49
R442	330 ohm; 0.1W; +-5%	Rohm	MCR03 EZHJ 331	0662057A37
R443	330 ohm; 0.1W; +-5%	Rohm	MCR03 EZHJ 331	0662057A37
R444	22 ohm; 0.1W; +-5%	Rohm	MCR03 EZHJ 220	0662057A09
R445	0.1ohm 1W	Hokuriku	LPR1R100FE	N/A
R446	100 Kohm; 0.1W; +-1%	Rohm	MCR03 EZHF 1003	0662057P95
R447	100 Kohm; 0.1W; +-1%	Rohm	MCR03 EZHF 1003	0662057P95
R448	97.6 Kohm; 0.1W; +-1%	Rohm	MCR03 EZHF 9762	N/A
R449	100 Kohm; 0.1W; +-1%	Rohm	MCR03 EZHF 1003	0662057P95
R450	100 Kohm; 0.1W; +-1%	Rohm	MCR03 EZHF 1003	0662057P95
R451	100 Kohm; 0.1W; +-1%	Rohm	MCR03 EZHF 1003	0662057P95
R452	100 Kohm; 0.1W; +-5%	Rohm	MCR03 EZHJ 104	0662057A97
R453	100 Kohm; 0.1W; +-5%	Rohm	MCR03 EZHJ 104	0662057A97
R454	10 Kohm; 0.1W; +-5%	Rohm	MCR03 EZHJ 103	0662057A73
R455	27 Kohm;0.1W;+-5%	Rohm	MCR03 EZHJ 273	0662057A83
R456	1 Mohm; 0.1W; +-5%	Rohm	MCR03 EZHJ 105	0662057B22
R457	15 Kohm; 0.1W; +-5%	Rohm	MCR03 EZHJ 153	0662057A77
R459	NU			
R466	1 Kohm; 0.1W; +-5%	Rohm	MCR03 EZHJ 102	0662057A49
R467	NU			
R468	0 ohm; 0.1W; +-5%	Rohm	MCR03 EZHJ 000	0662057B47
R470	22 ohm; 0.1W; +-5%	Rohm	MCR03 EZHJ 220	0662057A09
R501	0 ohm; 0.1W; +-5%	Rohm	MCR03 EZHJ 000	0662057B47
R502	47 Kohm; 0.1W; +-5%	Rohm	MCR03 EZHJ 473	0662057A89
R503	2.7 Kohm; 0.1W; +-5%	Rohm	MCR03 EZHJ 272	0662057A59
R505	2.2 Kohm; 0.1W; +-5%	Rohm	MCR03 EZHJ 222	0662057A57
R506	10 Kohm; 0.1W; +-5%	Rohm	MCR03 EZHJ 103	0662057A73

Circuit Ref	Description	Vendor	Vendor Part Number	Motorola Equivalent Part Number
R507	1 Kohm; 0.1W; +-5%	Rohm	MCR03 EZHJ 102	0662057A49
R508	10 Kohm; 0.1W; +-5%	Rohm	MCR03 EZHJ 103	0662057A73
R509	68 Kohm; 0.1W; +-5%	Rohm	MCR03 EZHJ 683	0662057A93
R510	470 Kohm; 0.1W; +-5%	Rohm	MCR03 EZHJ 474	0662057B14
R511	56 Kohm; 0.1W; +-5%	Rohm	MCR03 EZHJ 563	0662057A91
R512	47 Kohm; 0.1W; +-5%	Rohm	MCR03 EZHJ 473	0662057A89
R513	10 Kohm; 0.1W; +-5%	Rohm	MCR03 EZHJ 103	0662057A73
R514	1 Kohm; 0.1W; +-5%	Rohm	MCR03 EZHJ 102	0662057A49
R515	25.5 Kohm; 0.1W; +-1%	Rohm	MCR03 EZHF 2552	0662057T92
R516	29.4 Kohm; 0.1W; +-1%	Rohm	MCR03 EZHF 2942	0662057P29
R517	15.8 Kohm; 0.1W; +-1%	Rohm	MCR03 EZHF 1582	0662057Z03
R518	11.5 Kohm; 0.1W; +-1%	Rohm	MCR03 EZHF 1152	0662057Z35
R519	150 Kohm; 0.1W; +-1%	Rohm	MCR03 EZHF 1503	0662057P97
R520	4.22 Kohm; 0.1W; +-1%	Rohm	MCR03 EZHF 4221	N/A
R521	715 Kohm; 0.1W; +-1%	Rohm	MCR03 EZHF 7153	0662057T99
R522	NU			
R523	47 Kohm; 0.1W; +-5%	Rohm	MCR03 EZHJ 473	0662057A89
R524	2.2 Kohm; 0.1W; +-5%	Rohm	MCR03 EZHJ 222	0662057A57
R525	10 Kohm; 0.1W; +-5%	Rohm	MCR03 EZHJ 103	0662057A73
R526	0 ohm; 0.1W; +-5%	Rohm	MCR03 EZHJ 000	0662057B47
R527	10 Kohm; 0.1W; +-5%	Rohm	MCR03 EZHJ 103	0662057A73
R530	22 Kohm; 0.1W; +-5%	Rohm	MCR03 EZHJ 223	0662057A81
R531	22 Kohm; 0.1W; +-5%	Rohm	MCR03 EZHJ 223	0662057A81
R532	15 Mohm; 0.1W; +-5%	Rohm	MCR03 EZHJ 155	N/A
R534	330 Kohm; 0.1W; +-5%	Rohm	MCR03 EZHJ 334	0662057B10
R535	2.2 Kohm; 0.1W; +-5%	Rohm	MCR03 EZHJ 222	0662057A57
R536	1 Kohm; 0.1W; +-5%	Rohm	MCR03 EZHJ 102	0662057A49
R537	470 Kohm; 0.1W; +-5%	Rohm	MCR03 EZHJ 474	0662057B14
R538	100 Kohm; 0.1W; +-5%	Rohm	MCR03 EZHJ 104	0662057A97
R539	100 Kohm; 0.1W; +-5%	Rohm	MCR03 EZHJ 104	0662057A97
R540	22 Kohm; 0.1W; +-5%	Rohm	MCR03 EZHJ 223	0662057A81
R541	22 Kohm; 0.1W; +-5%	Rohm	MCR03 EZHJ 223	0662057A81
R542	22 Kohm; 0.1W; +-5%	Rohm	MCR03 EZHJ 223	0662057A81
R543	100 Kohm; 0.1W; +-5%	Rohm	MCR03 EZHJ 104	0662057A97
R544	100 Kohm; 0.1W; +-5%	Rohm	MCR03 EZHJ 104	0662057A97
R545	100 Kohm; 0.1W; +-5%	Rohm	MCR03 EZHJ 104	0662057A97
R546	100 Kohm; 0.1W; +-5%	Rohm	MCR03 EZHJ 104	0662057A97
R547	100 Kohm; 0.1W; +-5%	Rohm	MCR03 EZHJ 104	0662057A97
R548	10 Kohm; 0.1W; +-5%	Rohm	MCR03 EZHJ 103	0662057A73
R549	100 Kohm; 0.1W; +-5%	Rohm	MCR03 EZHJ 104	0662057A97
R550	1 Kohm; 0.1W; +-5%	Rohm	MCR03 EZHJ 102	0662057A49
R551	0 ohm; 0.1W; +-5%	Rohm	MCR03 EZHJ 000	0662057B47
R560	5.6 Kohm; 0.1W; +-1%	Rohm	MCR03 EZHF 562	N/A
R561	634 Kohm; 0.1W; +-5%	Rohm	MCR03 EZHF 6343	N/A
R563	0 ohm; 0.1W; +-5%	Rohm	MCR03 EZHJ 000	0662057B47
R564	82 Kohm; 0.1W; +-1%	Rohm	MCR03 EZHF 8202	N/A
R565	18 Kohm; 0.1W; +-5%	Rohm	MCR03 EZHJ 183	0662057A79
R566	6.8 Kohm; 0.1W; +-5%	Rohm	MCR03 EZHJ 682	0662057A69
R567	10K ohm	Murata	NTH5G16P39A103K07 TH	N/A
R568	4.7 Kohm; 0.1W; +-5%	Rohm	MCR03 EZHJ 472	0662057A65

Circuit Ref	Description	Vendor	Vendor Part Number	Motorola Equivalent Part Number
R569	1 Kohm; 0.25W; +-5%	Hokuriku	CR1/4-102J	N/A
R570	120 Kohm; 0.1W; +-5%	Rohm	MCR03 EZHJ 124	N/A
R571	220K ohm	Murata	NPC18WM224K03RB	N/A
R601	1 Mohm; 0.1W; +-5%	Rohm	MCR03 EZHJ 105	0662057B22
R602	6.8 Kohm; 0.1W; +-5%	Rohm	MCR03 EZHJ 682	0662057A69
R604	6.8 Kohm; 0.1W; +-5%	Rohm	MCR03 EZHJ 682	0662057A69
R605	100 Kohm; 0.1W; +-5%	Rohm	MCR03 EZHJ 104	0662057A97
R606	100 Kohm; 0.1W; +-5%	Rohm	MCR03 EZHJ 104	0662057A97
R607	100 Kohm; 0.1W; +-5%	Rohm	MCR03 EZHJ 104	0662057A97
R608	100 Kohm; 0.1W; +-5%	Rohm	MCR03 EZHJ 104	0662057A97
R609	680 Kohm; 0.1W; +-5%	Rohm	MCR03 EZHJ 684	0662057B18
R610	10 Kohm; 0.1W; +-5%	Rohm	MCR03 EZHJ 103	0662057A73
R611	50K ohm	Hokuriku	NSM3503J400J	N/A
R612	100 Kohm; 0.1W; +-5%	Rohm	MCR03 EZHJ 104	0662057A97
R615	12 Kohm; 0.1W; +-5%	Rohm	MCR03 EZHJ 123	0662057A51
R616	4.7 Kohm; 0.1W; +-5%	Rohm	MCR03 EZHJ 472	0662057A65
R617	100 Kohm; 0.1W; +-5%	Rohm	MCR03 EZHJ 104	0662057A97
R620	4.7 Kohm; 0.1W; +-5%	Rohm	MCR03 EZHJ 472	0662057A65
R621	330 Kohm; 0.1W; +-5%	Rohm	MCR03 EZHJ 334	0662057B10
R622	0 ohm; 0.1W; +-5%	Rohm	MCR03 EZHJ 000	0662057B47
R625	18 Kohm; 0.1W; +-5%	Rohm	MCR03 EZHJ 183	0662057A79
R626	18 Kohm; 0.1W; +-5%	Rohm	MCR03 EZHJ 183	0662057A79
R627	680 Kohm; 0.1W; +-5%	Rohm	MCR03 EZHJ 684	0662057B18
R628	0 ohm; 0.1W; +-5%	Rohm	MCR03 EZHJ 000	0662057B47
R629	NU			
R631	NU			
R632	0 ohm; 0.1W; +-5%	Rohm	MCR03 EZHJ 000	0662057B47
R633	12 Kohm; 0.1W; +-5%	Rohm	MCR03 EZHJ 123	0662057A51
R634	680 Kohm; 0.1W; +-5%	Rohm	MCR03 EZHJ 684	0662057B18
R635	1.2 Mohm; 0.1W; +-5%	Rohm	MCR03 EZHJ 125	0662057B24
R636	0 ohm; 0.1W; +-5%	Rohm	MCR03 EZHJ 000	0662057B47
R637	0 ohm; 0.1W; +-5%	Rohm	MCR03 EZHJ 000	0662057B47
R638	330 Kohm; 0.1W; +-5%	Rohm	MCR03 EZHJ 334	0662057B10
R639	150 Kohm; 0.1W; +-5%	Rohm	MCR03 EZHJ 154	0662057B02
R640	150 Kohm; 0.1W; +-5%	Rohm	MCR03 EZHJ 154	0662057B02
R641	680 Kohm; 0.1W; +-5%	Rohm	MCR03 EZHJ 684	0662057B18
R642	33 Kohm; 0.1W; +-1%	Rohm	MCR03 EZHF 3302	N/A
R643	22 Kohm; 0.1W; +-1%	Rohm	MCR03 EZHF 2202	N/A
R645	1 Mohm; 0.1W; +-5%	Rohm	MCR03 EZHJ 105	0662057B22
R646	1 Kohm; 0.1W; +-5%	Rohm	MCR03 EZHJ 102	0662057A49
R648	470 Kohm; 0.1W; +-5%	Rohm	MCR03 EZHJ 474	0662057B14
R649	100 Kohm; 0.1W; +-5%	Rohm	MCR03 EZHJ 104	0662057A97
R650	100 Kohm; 0.1W; +-5%	Rohm	MCR03 EZHJ 104	0662057A97
R651	100 Kohm; 0.1W; +-5%	Rohm	MCR03 EZHJ 104	0662057A97
R652	680 Kohm; 0.1W; +-5%	Rohm	MCR03 EZHJ 684	0662057B18
R654	10 Kohm; 0.1W; +-5%	Rohm	MCR03 EZHJ 103	0662057A73
R655	4.7 Kohm; 0.1W; +-5%	Rohm	MCR03 EZHJ 472	0662057A65
R656	100 ohm; 0.1W; +-5%	Rohm	MCR03 EZHJ 101	0662057A25
R657	0 ohm; 0.1W; +-5%	Rohm	MCR03 EZHJ 000	0662057B47
R658	820 ohm; 0.1W; +-5%	Rohm	MCR03 EZHJ 821	0662057A47
R659	12 Kohm; 0.1W; +-5%	Rohm	MCR03 EZHJ 123	0662057A51

Circuit Ref	Description	Vendor	Vendor Part Number	Motorola Equivalent Part Number
R660	NU			
R661	10 Kohm; 0.1W; +-5%	Rohm	MCR03 EZHJ 103	0662057A73
R663	100 Kohm; 0.1W; +-5%	Rohm	MCR03 EZHJ 104	0662057A97
R669	0 ohm; 0.1W; +-5%	Rohm	MCR03 EZHJ 000	0662057B47
R701	2.2 Kohm; 0.1W; +-5%	Rohm	MCR03 EZHJ 222	0662057A57
R702	1.5 Kohm; 0.1W; +-5%	Rohm	MCR03 EZHJ 152	0662057A53
R703	330 Kohm; 0.1W; +-5%	Rohm	MCR03 EZHJ 334	0662057B10
R704	47 Kohm; 0.1W; +-5%	Rohm	MCR03 EZHJ 473	0662057A89
R705	22 ohm; 0.1W; +-5%	Rohm	MCR03 EZHJ 220	0662057A09
R706	470 ohm; 0.1W; +-5%	Rohm	MCR03 EZHJ 471	0662057A41
R707	10 Kohm; 0.1W; +-5%	Rohm	MCR03 EZHJ 103	0662057A73
R708	2.2 Kohm; 0.1W; +-5%	Rohm	MCR03 EZHJ 222	0662057A57
R709	0.27 ohm; 0.125W; +-5%	Rohm	MCR10 EZHJ R27	0662057C02
R710	100 ohm; 0.1W; +-5%	Rohm	MCR03 EZHJ 101	0662057A25
R711	10 Kohm; 0.1W; +-5%	Rohm	MCR03 EZHJ 103	0662057A73
R712	1 Kohm; 0.1W; +-5%	Rohm	MCR03 EZHJ 102	0662057A49
R713	10 Kohm; 0.1W; +-5%	Rohm	MCR03 EZHJ 103	0662057A73
R714	10 Kohm; 0.1W; +-5%	Rohm	MCR03 EZHJ 103	0662057A73
R715	4.7 Kohm; 0.1W; +-5%	Rohm	MCR03 EZHJ 472	0662057A65
R716	0 ohm; 0.1W; +-5%	Rohm	MCR10 EZH J 000	0662057C01
R717	0 ohm; 0.1W; +-5%	Rohm	MCR10 EZH J 000	0662057C01
R718	22 Kohm; 0.1W; +-5%	Rohm	MCR03 EZHJ 223	0662057A81
R719	22 Kohm; 0.1W; +-5%	Rohm	MCR03 EZHJ 223	0662057A81
RV601	10 Kohm; 0.1W; +-5%	Rohm	MVR22 HXBR N 103	N/A
RV602	10 Kohm; 0.1W; +-5%	Rohm	MVR22 HXBR N 103	N/A

**This Page Intentionally Left Blank**

---

## Chapter 8 UHF Band Information

### 8.1 Model Charts

PRO2150 Portable Radio, UHF, 403-440 MHz		
Model		Description
LAH49QCH8AA9_N		PRO2150, 403-440MHz, 1-4W, 12.5/25K 99ch
	<b>Item</b>	<b>Description</b>
X	PMUE1809__L	PRO2150, 403-440MHz, 1-4W, 12.5/25K
X	DS1M001110	Front Cover Kit
X	DS1M001120	Chassis Hardware Kit
X	DS1M001130	Knob Assembly
X	DS1M001140	Ext. Cover Kit
X	DS1M011513	Controller Board Assembly, UHF, 403-440MHz PRO2150
X	DS1M001161	RF Board Assembly, UHF, 403-440MHz PRO2150
X	DS1M001170	LCD Kit
X	DS1M001190	Speaker Assembly
X	DSM1B26051	Screw M2.6
X	DSM2192004	Contact Gasket
X	DSM2192005	Main Gasket
X	DSM2192006	Volume Gasket
X	DSM4193013	Gasket (Screw 26)
X	DSM5190001	Housing Back
X	DSM6189003	PTT Button
X	PMNN4046_	Battery, Standard NiMH
X	PMTN4053_	Std. Wall Charger 110V US
X	DSM4193042	PRO2150 Nameplate
X	PMAE4010_	Std. 10 cm Antenna, 403-440 MHz
X	HLN9844_	Belt Clip
X	HKLN4197_	PRO2150 Portable Radio User Guide CD (English, Spanish, and Portuguese)

x = Indicates one of each is required.

---

PRO2150 Portable Radio, UHF, 435-480 MHz	
Model	Description
LAH49RCH8AA9_N	PRO2150, 435-480MHz, 1-4W, 12.5/25K, 99ch
	<b>Item</b>
	<b>Description</b>
X	PMUE1813__L
X	DS1M001110
X	DS1M001120
X	DS1M001130
X	DS1M001140
X	DS1M011521
X	DS1M001162
X	DS1M001170
X	DS1M001190
X	DSM1B26051
X	DSM2192004
X	DSM2192005
X	DSM2192006
X	DSM4193013
X	DSM5190001
X	DSM6189003
X	PMNN4046_
X	PMTN4053_
X	PMAE4011_
X	HLN9844_
X	HKLN4197_
X	DSM4193042

x = Indicates one of each is required.



## 8.2 Specifications

### General

	UHF	
Frequency:	403-440 MHz 435-480 MHz	
Channel Capacity:	99	
Power Supply:	7.5 Volts $\pm$ 20%	
Dimensions with Standard High Capacity NiMH Battery:	115.5mm x 56mm x 35mm	
Weight: with Standard High Capacity NiMH Battery:	350 g	
Average Battery Life @ (5-5-90 Duty Cycle)	(Low Power) >11 hrs	(High Power) >8 hrs
Sealing:	Passes rain testing per IPX4 (EN60529=1991)	
Shock and Vibration:	Meets MIL STD 810C, D and E	
Dust:	Meets MIL STD 810C, D and E	
Humidity:	Weather resistant housing passes EIA RS-316B	

### Transmitter

	UHF	
RF Output NiMH @ 7.5V:	Low 1W	High 4W
Channel Spacing	12.5/25 kHz	
Freq. Stability (-30°C to +60°C)	0.00025%	
Spurs/Harmonics:	-26 dBm	
Audio Response: (from 6 dB/oct. Pre-Emphasis, 300 to 3000Hz)	+1, -3 dB	
Audio Distortion: @ 1000 Hz, 60% Rated Max. Dev.	<5%	
FM Noise:	40 dB	

### Receiver

	UHF 12.5kHz	UHF 25kHz
Sensitivity 12dB SINAD:	0.25 $\mu$ V	0.25 $\mu$ V
Adjacent Channel Selectivity EIA	60 dB	65 dB
Intermodulation	60 dB	65 dB
Spur Rejection:	60 dB	65 dB
Image Rejection:	60 dB	65 dB
Hum and Noise	40 dB	
Audio Distortion	< 5%	
Conducted Emmission	-57 dBm	
Audio Output @ <5% Distortion	500 mW	500 mW

## 8.3 Theory of Operation

### 8.3.1 General Information

Your radio has two printed circuit boards: the Controller board, and the Radio Frequency (RF) board. The Controller board contains the CPU/Control section. The RF board contains the VCO/Synthesizer section, Transmitter section, Receiver section, Transmitter Audio circuitry, Receiver Audio circuitry, and Battery section.

### 8.3.2 Power Distribution

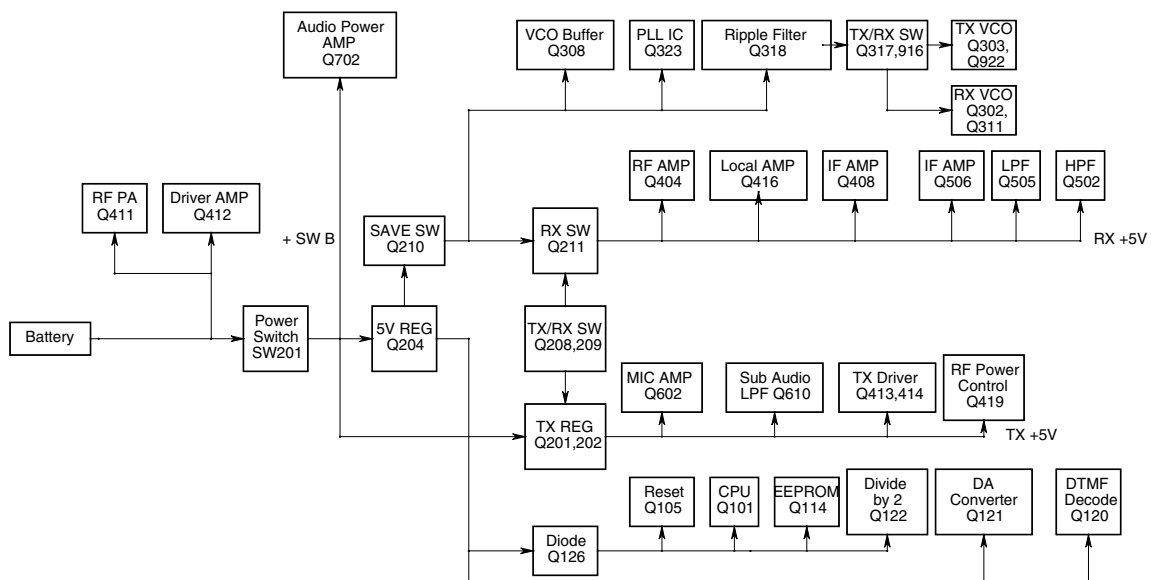

Figure 8-1.

The above figure illustrates the DC distribution throughout the radio board. A battery supplies power directly to the electronic on/off control. Radio power supply is triggered by the **Power Switch** (On/Off/Volume control) and **+SW B** is distributed as show in the figure. Regulator output 5V is supplied to the CPU. **+SW B** continues to support the Audio Power AMP, 5V Regulator, TX Regulator until the radio is turned off.

The radio can be turned off on two ways:

1. **Power Switch** turned-off
2. Low Battery

When a low battery level is detected by the CPU, it stores the radio personality data to EEPROM before turning off the radio.

### 8.3.3 Power up Sequence

1. Power supply is turned on by the On/Off/Volume Control (Power Switch).
2. Power from battery is supplied to the regulator through the switch.
3. Output (5V) from the regulator is directed to the CPU (**Q101**).
4. **Q105** resets the CPU (**Q101**).
5. The CPU loads radio personality data from EEPROM after the reset.

6. This personality data is used to initialize the radio.
7. The radio restores last power up state (i.e. state before the radio was turned-off).
8. Power is supplied to PLL circuitry.
9. Power is supplied to Rx and Rx VCO circuitry.
10. CPU sends data to PLL circuitry. If LOCK status is confirmed, radio continues the power-up sequence. Otherwise, PLL ERR is displayed.
11. If the Rx audio level is less than the pre-programmed squelch level, and other unmuting conditions are met, the radio will open squelch.

### 8.3.4 CPU / Control Section

When the radio is turned ON, the CPU (**Q101**) reads the radio status from the EEPROM **Q114**. It also monitors the keypad, the PTT line and other inputs such as the squelch detect, etc. continuously. When there is a channel change, the CPU sends the correct frequency information to the synthesizer via pins 1, 2 and 89. The CPU is clocked by the 8.388608MHz oscillator, which is composed of **X101**, **C101**, **C106**, and **R158**.

### 8.3.5 VCO / Synthesizer Section

This section consists of the Temperature-Compensated Crystal Oscillator(TCXO), Voltage Controlled Oscillator(VCO), Synthesizer and the Loop Filter. These circuits are found on the RF board.

#### 8.3.5.1 Temperature-Compensated Crystal Oscillator (TCXO)

The reference oscillator is a temperature compensated crystal-controlled, Pierce type circuit. It utilizes a logic gate within **Q323** as a gain element. **C335** is used to adjust the oscillator on frequency (14.4MHz) at room temperature (22°C). Temperature variations cause resistance changes in thermistor **R330** and **R567**, which is on the base of **Q320**, thus varying the voltage applied to varactor **Q322**. This changes the impedance across crystal **X301** in a manner complementary to the temperature drift characteristic of the crystal. In this way, the reference oscillator is held within the specified  $\pm 2.5$  PPM from -30 to +60°C.

#### 8.3.5.2 Voltage-Controlled Oscillators

Only one of the VCOs runs at a time, which is controlled by **Q317** and **Q101**. The receive VCO consists of **C311**, **C314-C316**, **C913**, **C940**, **L302-L306**, **Q311** and **Q302**. This VCO oscillates at 45.1 MHz above the programmed receive frequency. The VCO's oscillating frequency is tuned by the varactor **Q311**. The tuning voltage is supplied from the output of the Loop Filter. The output of the VCO is AC coupled (**C311**) to the buffer **Q308**. The output of the VCO buffer **Q308** is AC coupled (**C308**) to the synthesizer and the output buffer **Q416** respectively.

When the PTT is pressed, **Q101** pin36 goes low (approx. 0V) disabling the receive VCO by the **Q317** and biases on **Q916** to enable the transmitter VCO. The transmitter VCO consists of **C340**, **C935-C937**, **L308-L310**, **Q303**, **Q921** and **Q922**. This VCO oscillates on the programmed transmit frequency. The VCO's oscillating frequency is tuned by the varactor **Q922**. The tuning voltage is supplied from the output of the Loop Filter. The transmit voltage controlled oscillator is directly frequency-modulated and operates on the carrier frequency. The synthesizer is tuned in 5.00kHz or 6.25kHz steps.

### 8.3.5.3 Synthesizer

The frequency synthesizer is a large-scale monolithic synthesizer integrated circuit **Q323**. The synthesizer IC contains a dual modulus prescaler, programmable divide-by-N counter, prescale control (swallow) counter, reference oscillator, reference divider, phase detector, charge pump and lock detector. Also, included in **Q323** are shift registers and control circuits for frequency controls and general device control.

RF output from the active VCO is AC coupled to the synthesizer **Q323** prescaler input at Pin 8. The divide counter chain in **Q323**, consisting of the dual-modulus prescaler, swallow counter and programmable counter, divides the VCO signal down to a frequency very close to 5.00kHz or 6.25kHz which is applied to the phase detector. The phase comparator compares the phase with the 5.00kHz or 6.25kHz reference signal from the reference divider and drives the external charge pump (**Q314**, **Q315** and **Q316**). The synthesizer unlock detector circuit prevents the operation of the transmitter and receiver, when the phase lock loop (PLL) is unlocked. The following discussion assumes the unit has been placed in the transmit mode. **Q323** lock detector Pin 7 goes high when the PLL is locked. This high level is applied to Pin 25 of the CPU **Q101**. A software timing routing brings the RX/TX line low (Pin 36 of **Q101**). With the RX/TX line goes low, **Q209** is cut off and **Q208** is biased on passing **+5VTX-B** to **Q202**; it biases on **Q201** to pass switched **TX-B** to the transmitter amplifier string which enables transmission.

When the PLL is unlocked, the lock detector at **Q323** Pin 7 will begin pulsing low. A RC circuit converts this low pulse to a low level for the CPU. The CPU then changes the RX/TX line to a high, thus signaling the other transistor switches to drive **Q201** into cutoff, which disables transmission. Therefore, the transmitter remains disabled while the loop remains out of lock, and "PLL ERR" is displayed.

### 8.3.5.4 Loop Filter

The Loop Filter, a passive lead-lag filter consisting of **R314-R317**, **R356**, **C323**, **C369**, and **C371**, integrates the charge pump output to produce the DC turning voltage for the VCO. One parasitic pole, consisting of RF chokes **L306** and **L310**, prevent modulation of the VCOs by the 5.00kHz or 6.25kHz reference energy remaining at the output of the loop filter. Direct FM is obtained for modulating frequencies outside the PLL bandwidth by applying the CTCSS/DCS signals and the pre-emphasized, limited microphone audio to the VCO modulation circuit. The modulation circuit consists of **R929** and **Q921**.

## 8.3.6 Transmitter Section

### 8.3.6.1 RF Power Amplifier

After the PTT is pressed, the **+5VTX-B** line switches to approximately 5V. **Q916** is turned on, enabling transmit VCO. The VCO buffer, pre-driver, driver and power amplifier are biased on by **Q201**. **Q201** is biased on by the **+5VTX-B** line switching to 5V. RF output from the transmit VCO(**Q303**) is applied to the VCO output buffer **Q308**. Output from **Q308** feeds the buffer **Q414**. The output signal from **Q414** feeds the pre-driver amplifier **Q413**, and feeds the driver amplifier **Q412**, whose output from the driver stage feeds the final RF power amplifier **Q411** to produce the rated output power of 5 watts. The final output is fed to a low-pass filter (**C435-438**, **C491-C493**, **L418**, and **L430**) and then to the transmit/receive switch **Q410**. RF power is then fed to the antenna via the output low-pass filter consisting of **C439-C444**, **C475**, **L414**, **L415** and **L416**.

### 8.3.6.2 Antenna Switching

Switching of the antenna between the transmitter and the receiver is accomplished by the antenna transmit/receive switch consisting of diodes **Q409** and **Q410**. In the transmit mode, switched **TX B+** is applied through **R417** and RF choke **L417**, hard forward biasing the two diodes on **Q410**, thus permitting the flow of RF power from the output of the low-pass filter. **L419** and **C433** isolate the receiver circuit from the transmitter power input.

### 8.3.6.3 Power Control

Output power is controlled by the CPU (**Q101**), the D/A converter (**Q121**), the dual Op-Amp (**Q419**), which is used as a differential amplifier and comparator. Current is sensed by the voltage drop across **R442**. When the radio is in high power mode, this voltage is compared to the D/A converter voltage at 5-watt. When the radio is in low power mode, this voltage is compared to the D/A converter voltage at 1-watt. The power output is then reduced or increased by varying the applied voltage to the gate of the power amplifier **Q411** and **Q412**.

### 8.3.6.4 Transmitter Audio Circuits

The transmitter audio circuits consist of the audio processing circuits, the CTCSS circuits and the DCS circuits.

#### 8.3.6.4.1 Audio Processing

Transmit speech audio is provided by either the internal electric microphone **M101** or the external microphone. The audio is pre-emphasized by 6dB per octave by **C615** and **R655**, and then its signal is amplified. The microphone audio is directed to amplifier **Q602B**, **Q602A** and low-pass filter **Q602C** and **Q602D**. **Q602A** has limiting function. The modulation adjustment is done by Pot **RV601**, and directed to a four-pole active low-pass filter. The resulting signal is then limited, and is directed to a low pass filter (18dB per octave roll-off above 3KHz). The audio is then directed through the 25KHz/12.5KHz channel spacing SW **Q601** to varactor diode **Q329** in transmit VCO. By varying the voltage on the varactor diode **Q329** at an audio rate, VCO output is frequency-modulated.

#### 8.3.6.4.2 CTCSS Tone Encoder / Digital Code Squelch (DCS) Encoder

CTCSS signals and DCS signals are synthesized by CPU **Q101** and appear as pulse waveform on I/O line Pin 7. This I/O line is connected to a digital-to-analog converter network (consisting of **C136**, **C173**, **R150** and **R182**), which produces a pseudo-sine wave at its output. The waveform is smoothed by low pass filters **Q610B** to produce an acceptable sine wave output. The CTCSS tone signal is adjusted to the proper level by **RV602**.

## 8.3.7 Receiver Section

### 8.3.7.1 Receiver Front End

In the receive mode, the RF signal enters through the antenna, then through the low-pass filter **C439-C445**, and **L414-L416**. The diodes **Q409** and **Q410** are biased off, so that the output of the low-pass filter is coupled to the first band-pass filter **C401-C409**, **L401**, **L402**, **Q401**, **Q402**, **R401**, **R402** and to the Front End RF overload protection diode pair **Q403**. The signal from the band-pass filter is directed to the input of the RF amplifier **Q404**. The output of the RF amplifier is sent to three stages of band-pass filters, consisting of **C413-C417**, **C419-C422**, **C487**, **L405-L407**, **Q405**, **Q406** and **R408-R410**. The output from the band-pass filter is directed to the mixer's **Q407**, **L408** and **L409**.

### 8.3.7.2 Local Oscillator (LO)

The Receive VCO (**C311**, **C314 -C316**, **C913**, **C940**, **L302- L306**, **L312-L314**, **Q311**, and **Q302**) provides the LO signal. The VCO is running at 45.1 MHz above the desired receive frequency and is applied to output Buffer **Q308** and **Q416**. The output of the buffer is sent through the low-pass filter **C424**, **C425**, **L410**, **L411** and to the mixer **Q407**, **L408** and **L409**.

### 8.3.7.3 Mixer

The mixer is a DBM type (**L408**, **L409**, **Q407**). The mixer LO frequency is 45.1 MHz above the desired receiver frequency. When the receiver frequency is present, the mixer output will be a 45.1MHz signal. The mixer output is peaked for 45.1MHz at **L412**, **C426** and **R412**, and the signal is filtered by crystal filter **F402** and amplified by **Q408** before being sent to IF IC **Q506**. The 45.1MHz IF signal and LO frequency of 44.645 MHz (**X501**) are mixed in **Q506**. The 455kHz ceramic filter, **F501** or **F502**, filters the second mixer's output. The resulting signal is the second IF signal. The mixer's output is then fed to the internal limiting amplifier, and consequently to the FM decoder.

### 8.3.7.4 FM Detector and Squelch

The FM detector output is used for squelch, decoding tones and audio output. The squelch amplifier is inside of **Q506**, and its output is fed to an internal rectifier and squelch detector. The output on **Q506** Pin 14 signals the CPU **Q101** with a low (~0V) to unmute the radio. The audio is unmuted by the CPU **Q101** Pin 41 switching to a high (5V), thus biasing on **Q503**. The audio is then routed to the audio amplifier **Q702** via the volume control **SW201**.

### 8.3.7.5 Receiver Audio Circuit

The detector's audio output also is fed to the tone (CTCSS and DCS) low-pass filter **Q505A**. Then the output of the low-pass filter is routed to the second stage filter **Q505B**. The output of **Q505B** is passed to **Q505C**. The output of **Q505C** is directed to the squaring circuit **Q505D**, and finally to the CPU **Q101** Pin22 for decoding.

The detector output feeds the audio high-pass filter **Q502**. The output of the audio high-pass filter feeds the Volume Control **SW201** (VOL). From the wiper arm on the Volume Control, the audio is routed to Pin 4, which is the input to the audio power amplifier **Q702**. The output of the audio power amplifier is routed through the earphone jack **J701** to the internal speaker **SP701**.

## 8.3.8 Battery Section

The battery connects to the contact (**CN201**). The positive terminal of the battery connects to the ON/OFF Volume control switch (**SW201**), and the negative terminal connects to PWB ground. Low battery is detected by **R127/R128** and voltage regulator **Q204**.

Battery voltage status is monitored by Pin 19 of the CPU **Q101** through **R127/R128**. When the battery voltage goes below the threshold voltage, "LOW BATT" is displayed on LCD **LC101**. In the BATTERY SAVER Mode, the CPU **Q101** generates a square wave signal on Pin 37. The signal's duty cycle varies according to what the BATTERY SAVE TIMER is set. When the signal goes high (approximately 5 V), **Q210** is biased off, and **Q211** is cut off, thus turning the supply off to IF IC **Q506**.

# 8.4 Block Diagrams

## 8.4.1 Complete

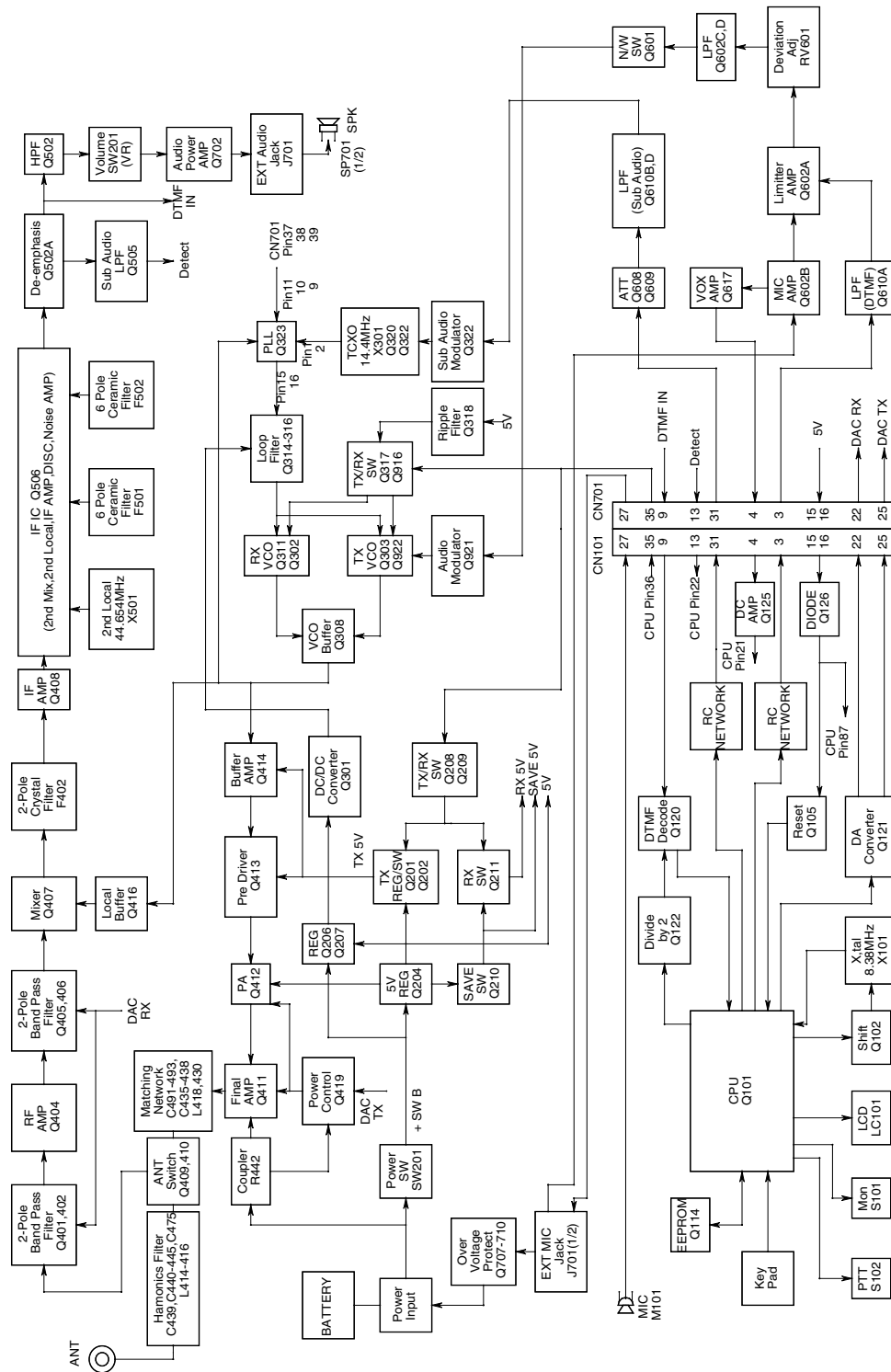

Figure 8-2.

### 8.4.2 Controller

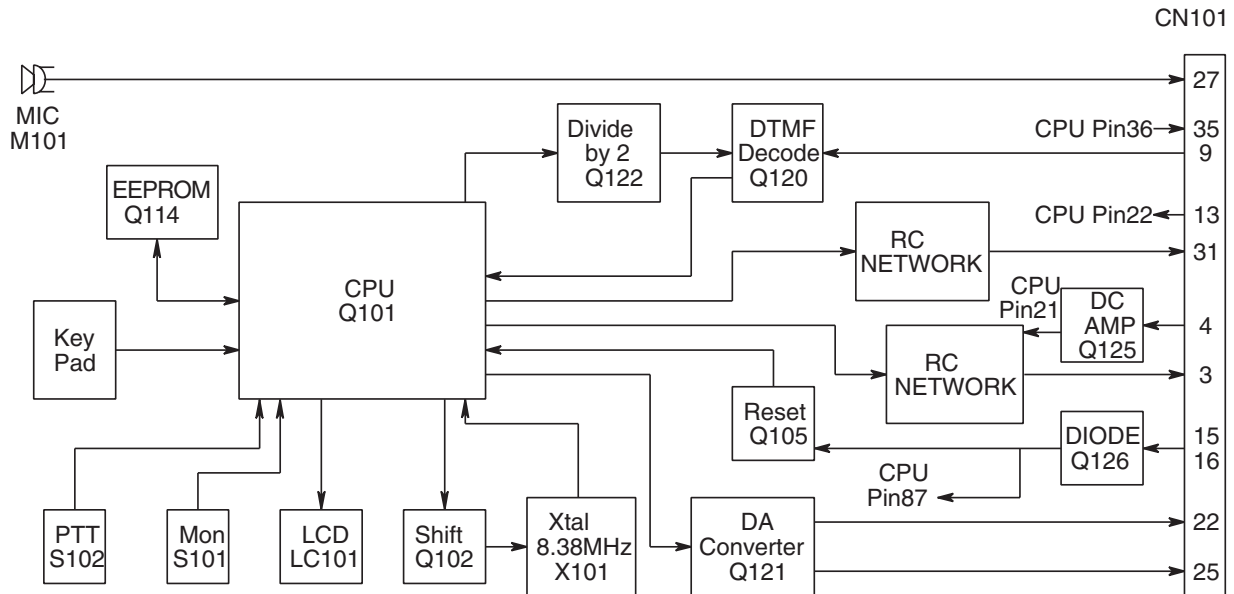

Figure 8-3.

### 8.4.3 VCO

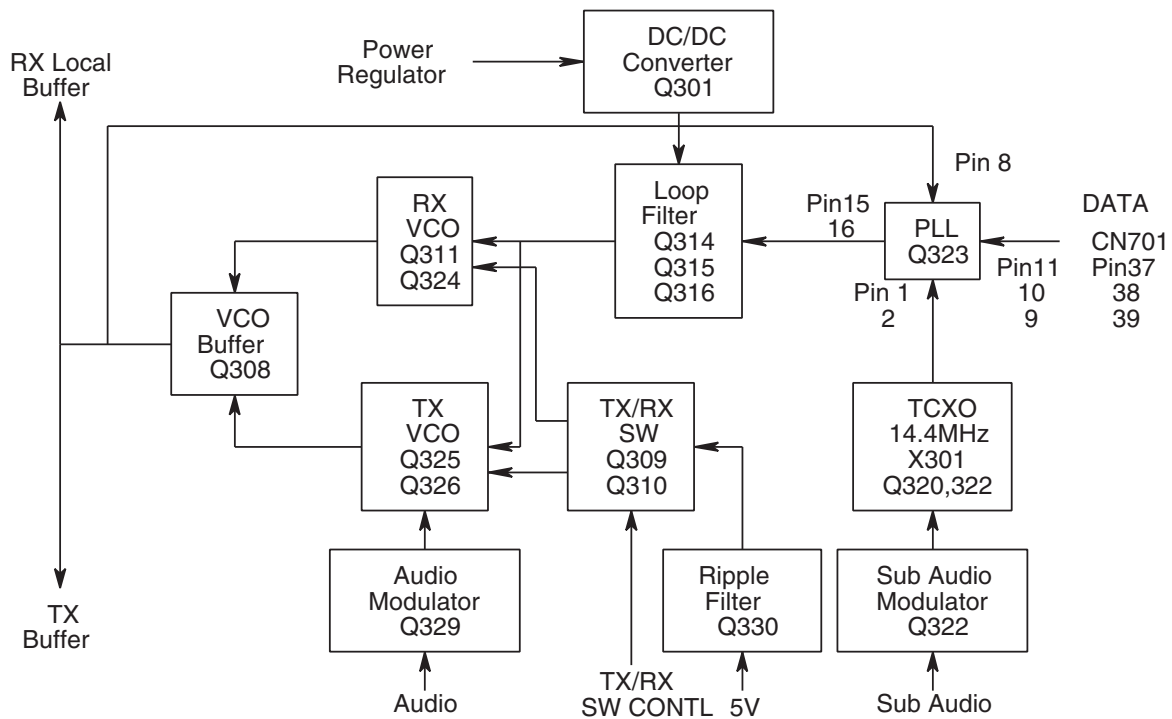

Figure 8-4.



### 8.4.4 Transmitter

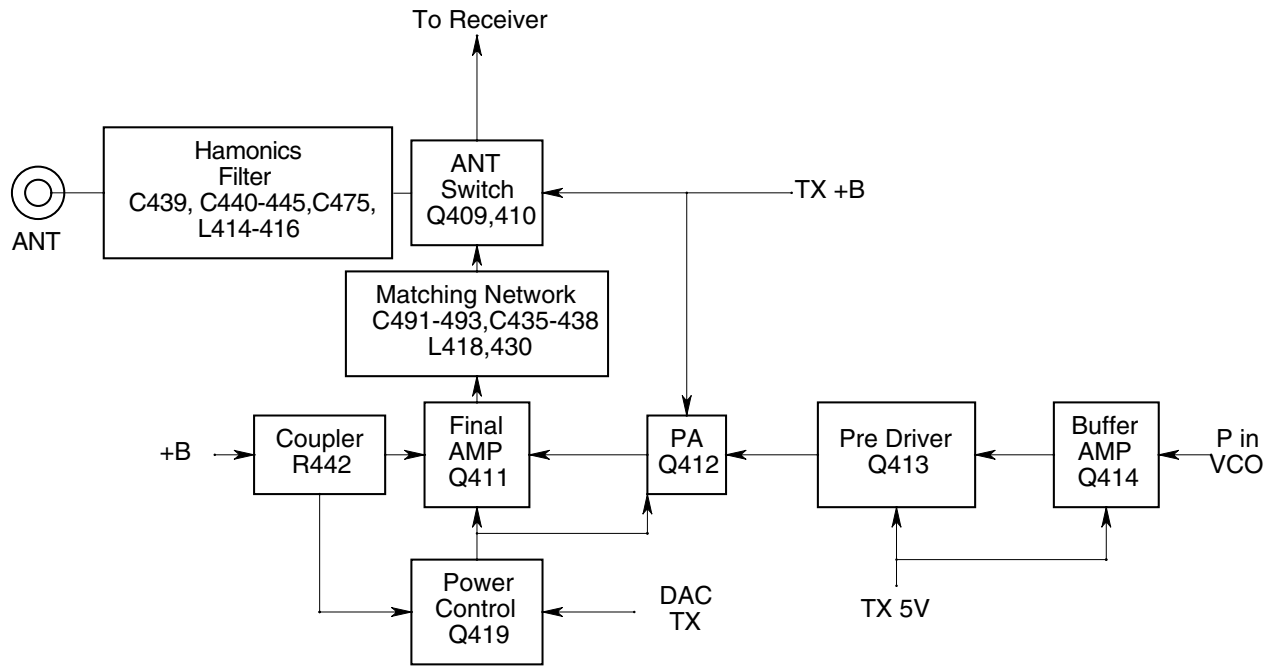

Figure 8-5.

### 8.4.5 Receiver

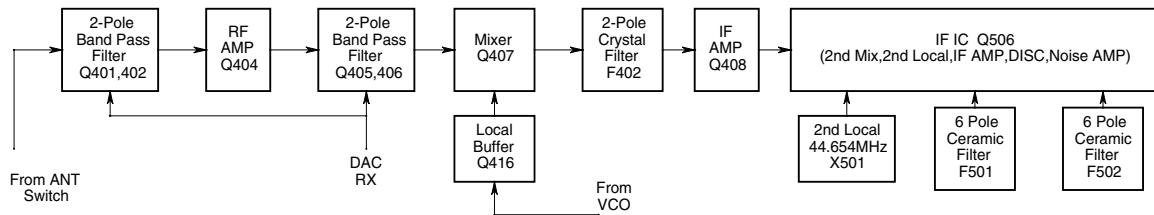
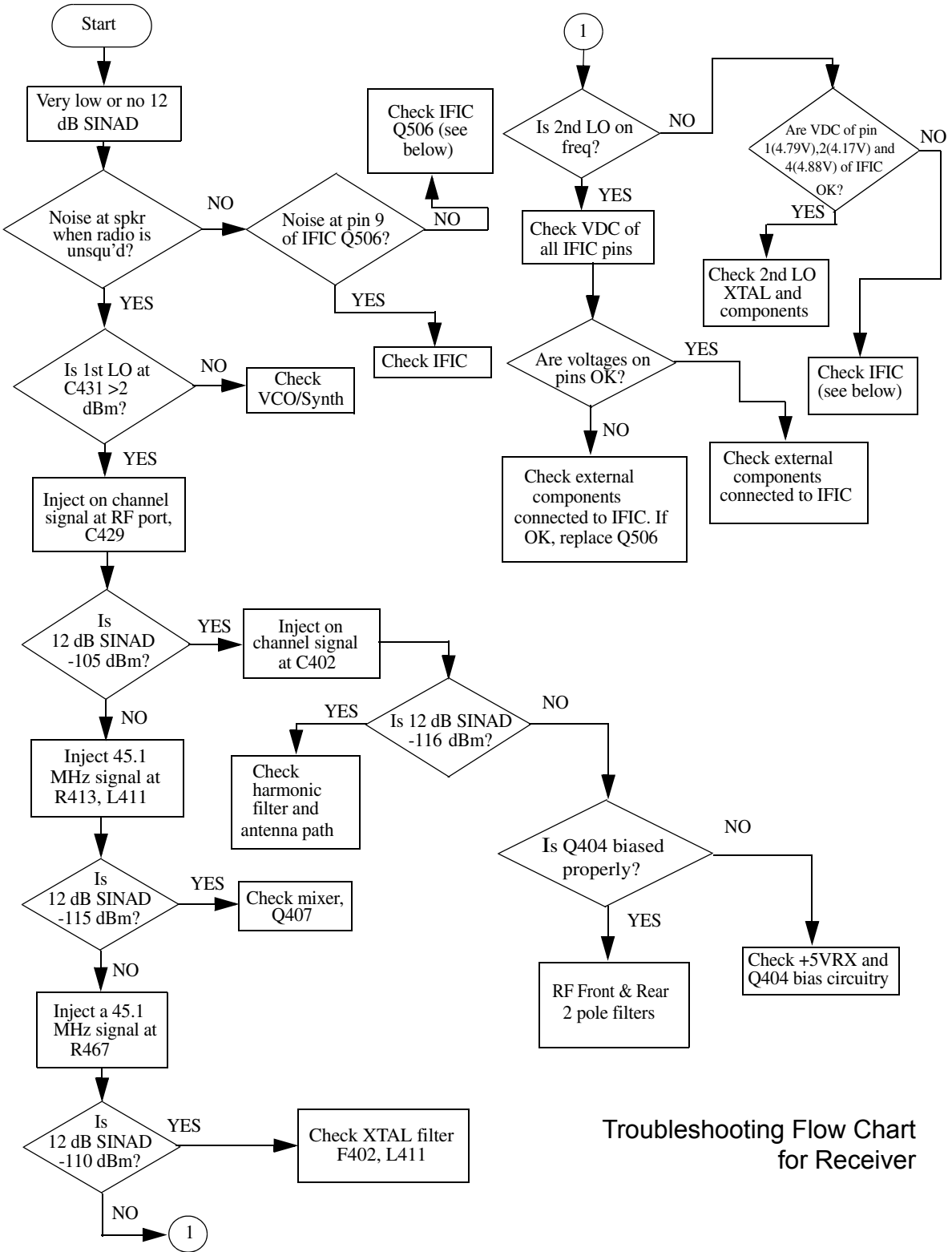

Figure 8-6.

### 8.5 Troubleshooting Charts



Troubleshooting Flow Chart for Receiver

Figure 8-7.

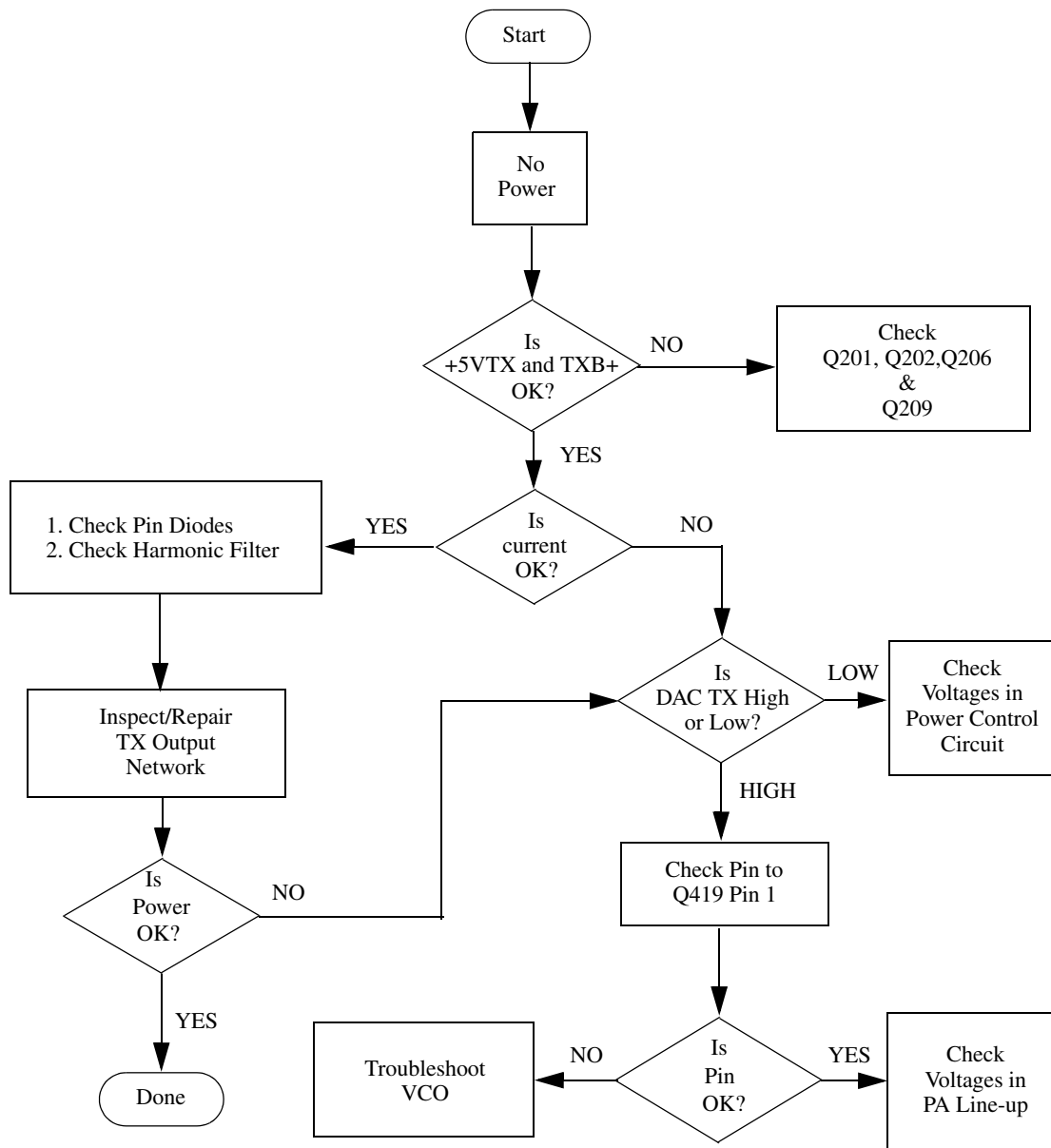

Troubleshooting Flow Chart for Transmitter

Figure 8-8.

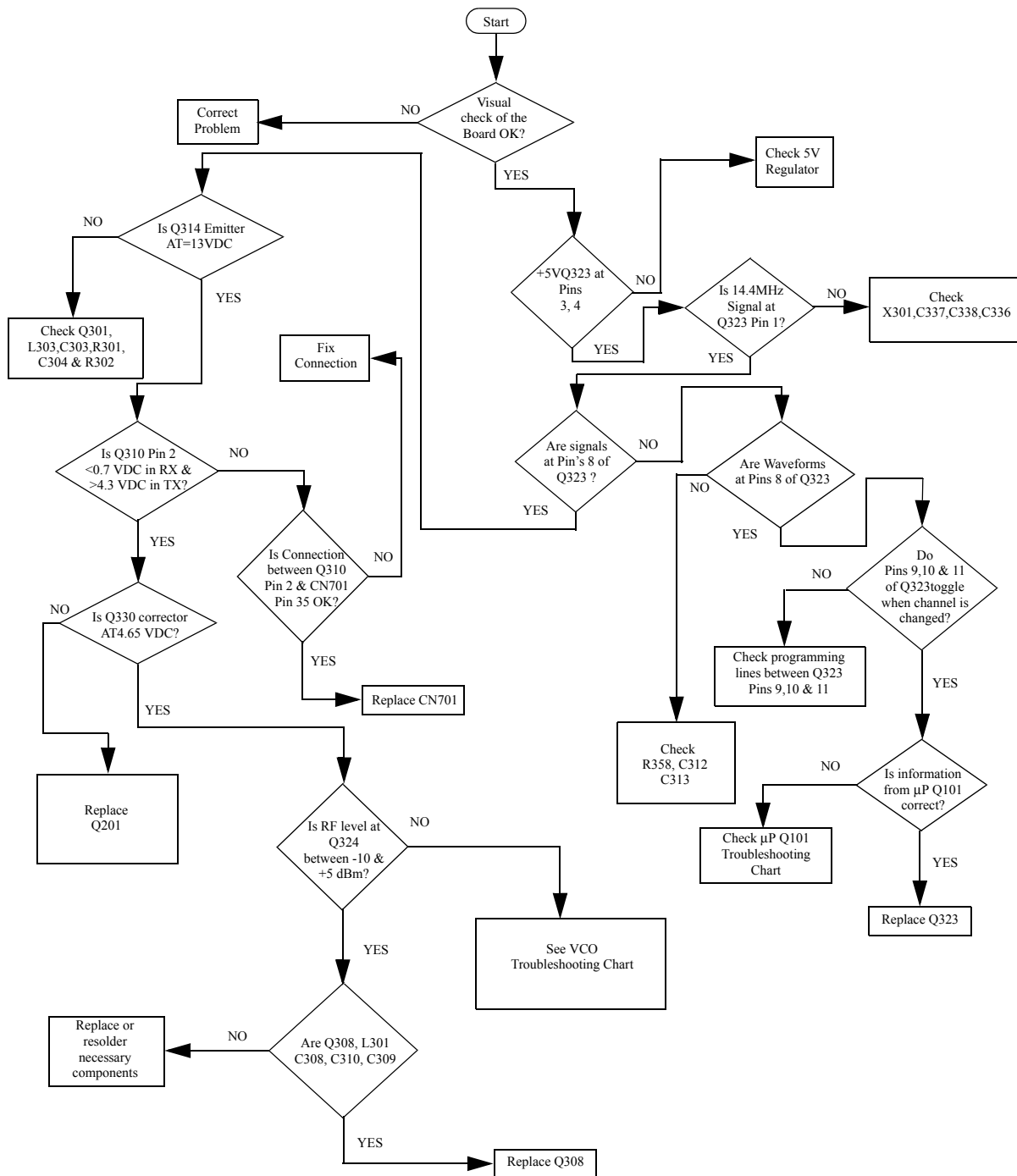

Troubleshooting Flow Chart for Synthesizer

Figure 8-9.

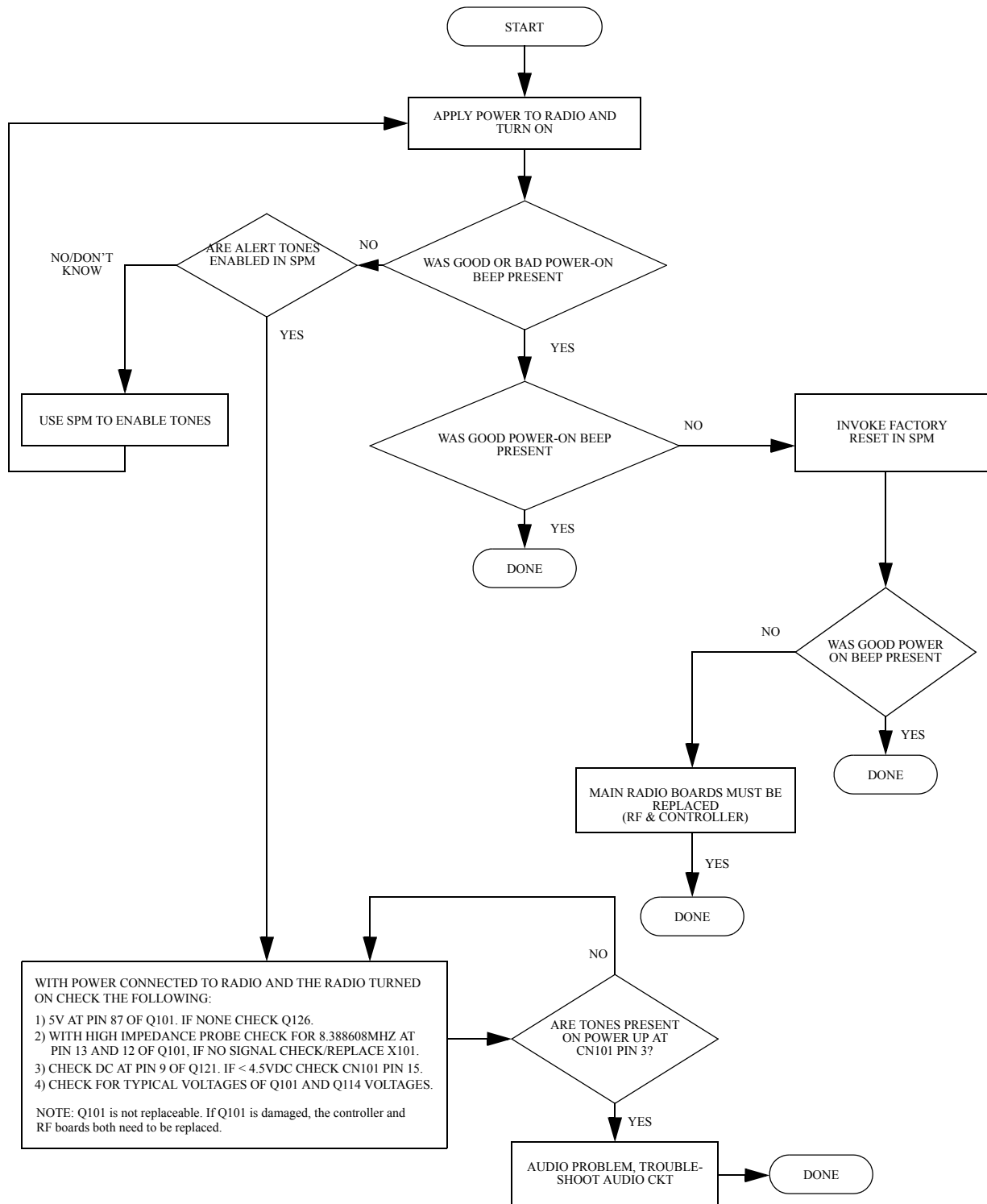

Troubleshooting Flow Chart for Microcontroller

Figure 8-10.

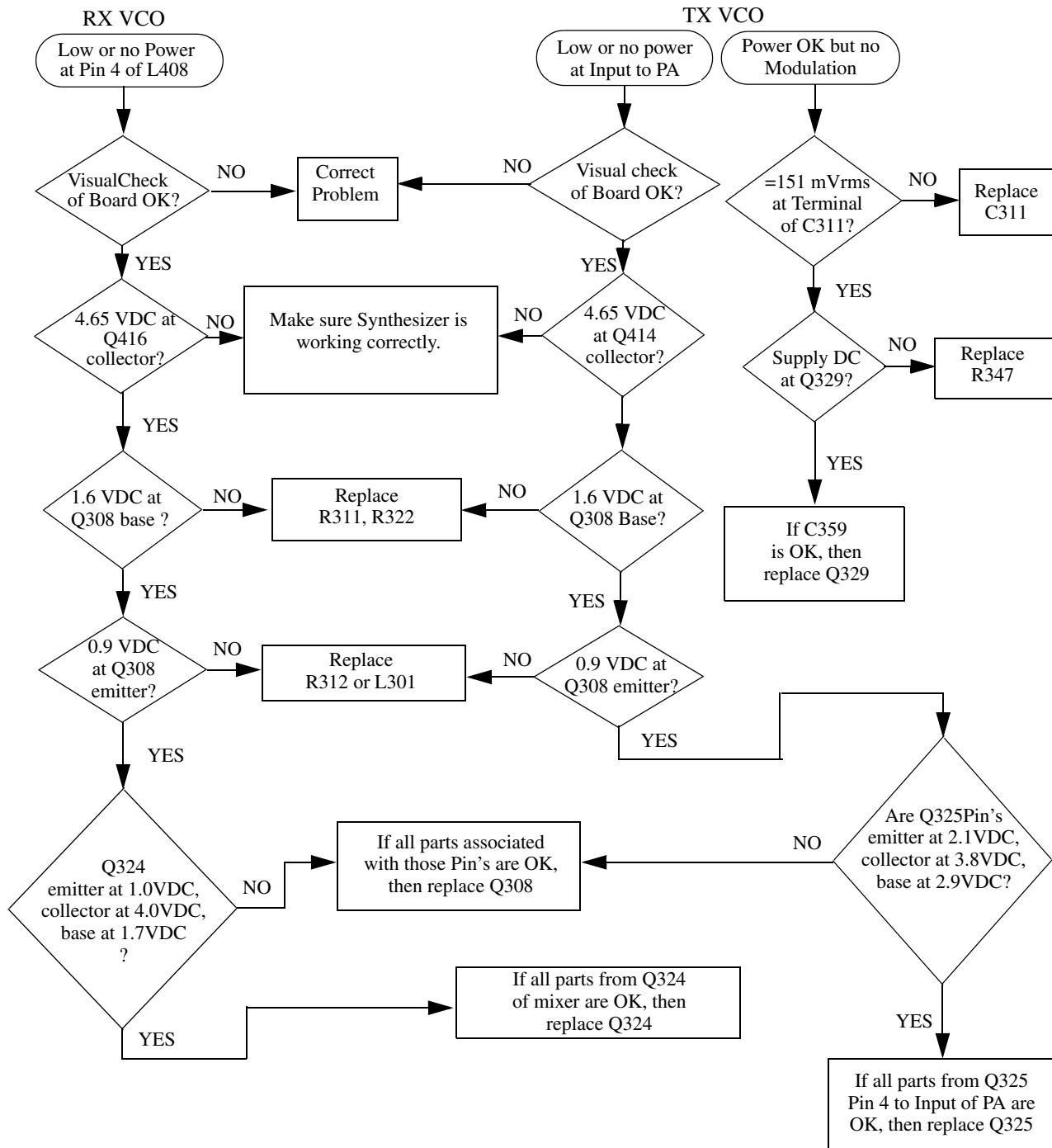

Note: Test Frequency 158MHz

Troubleshooting Flow Chart for VCO

Figure 8-11.

---

**Chapter 8 UHF 403-440 MHz Circuit Board/Schematic Diagrams and Parts List**

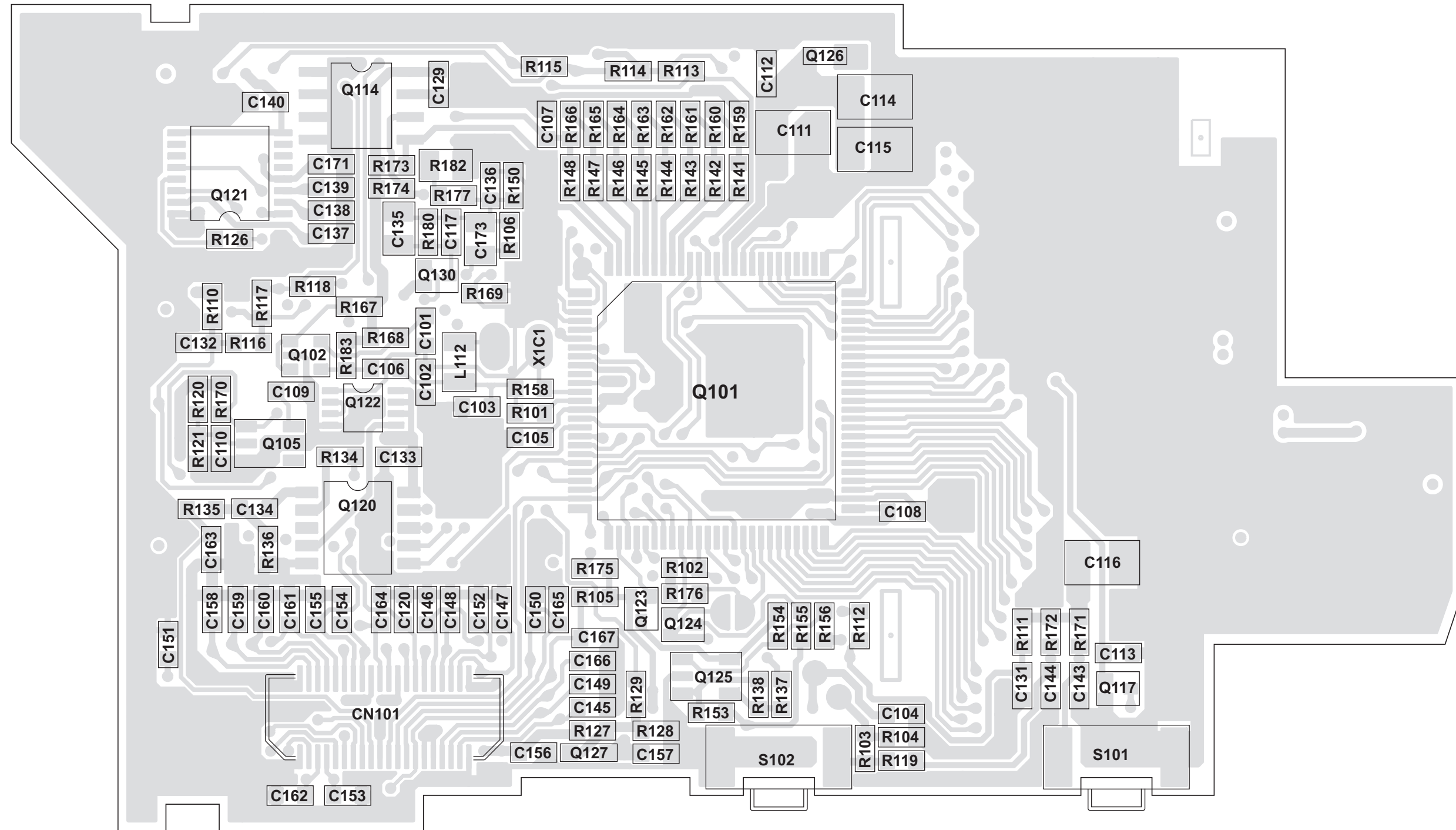

Figure 8-12. UHF 403-440 MHz Controller Board



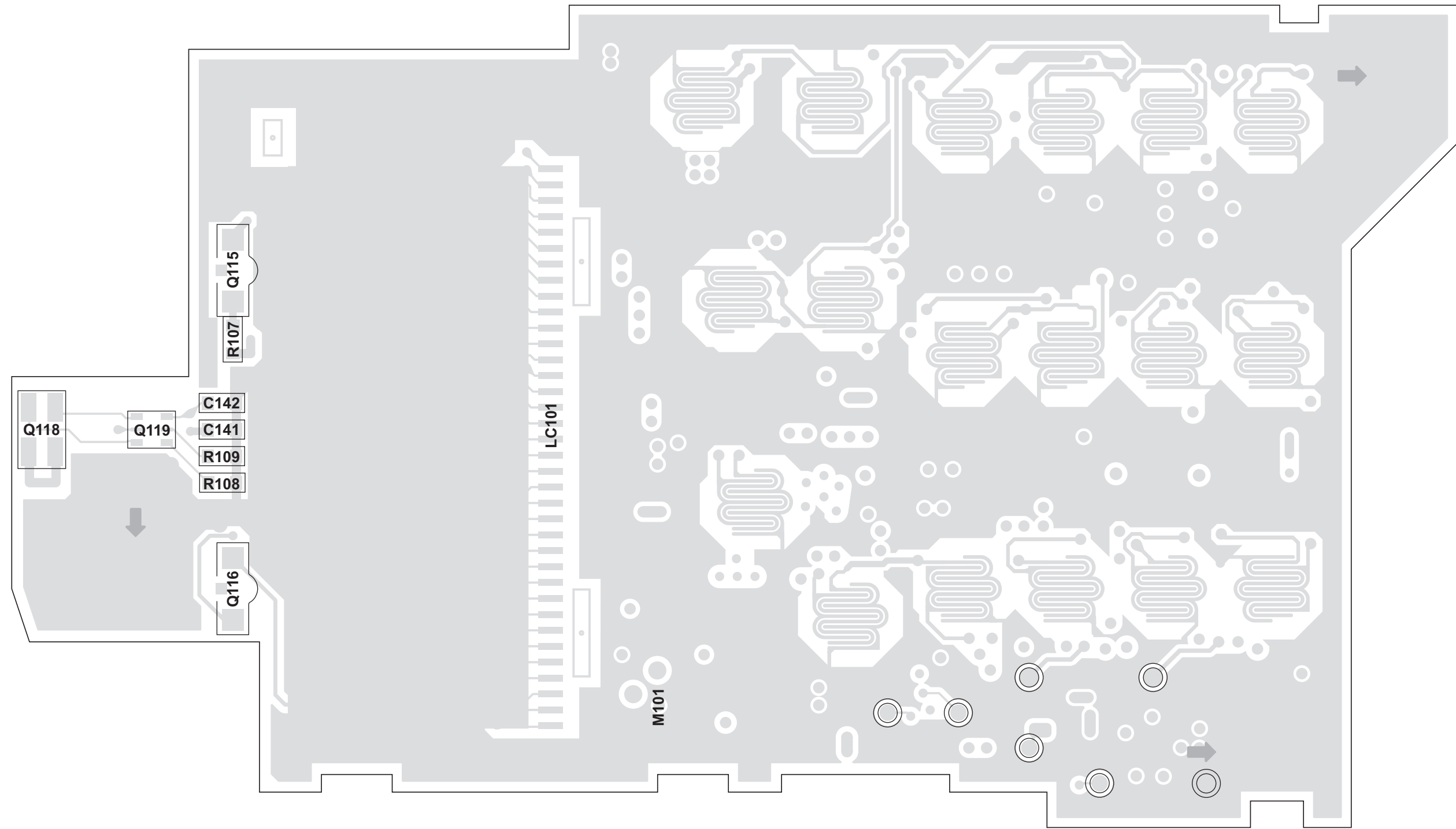

Figure 8-13. UHF 403-440 MHz Top Side Controller Board

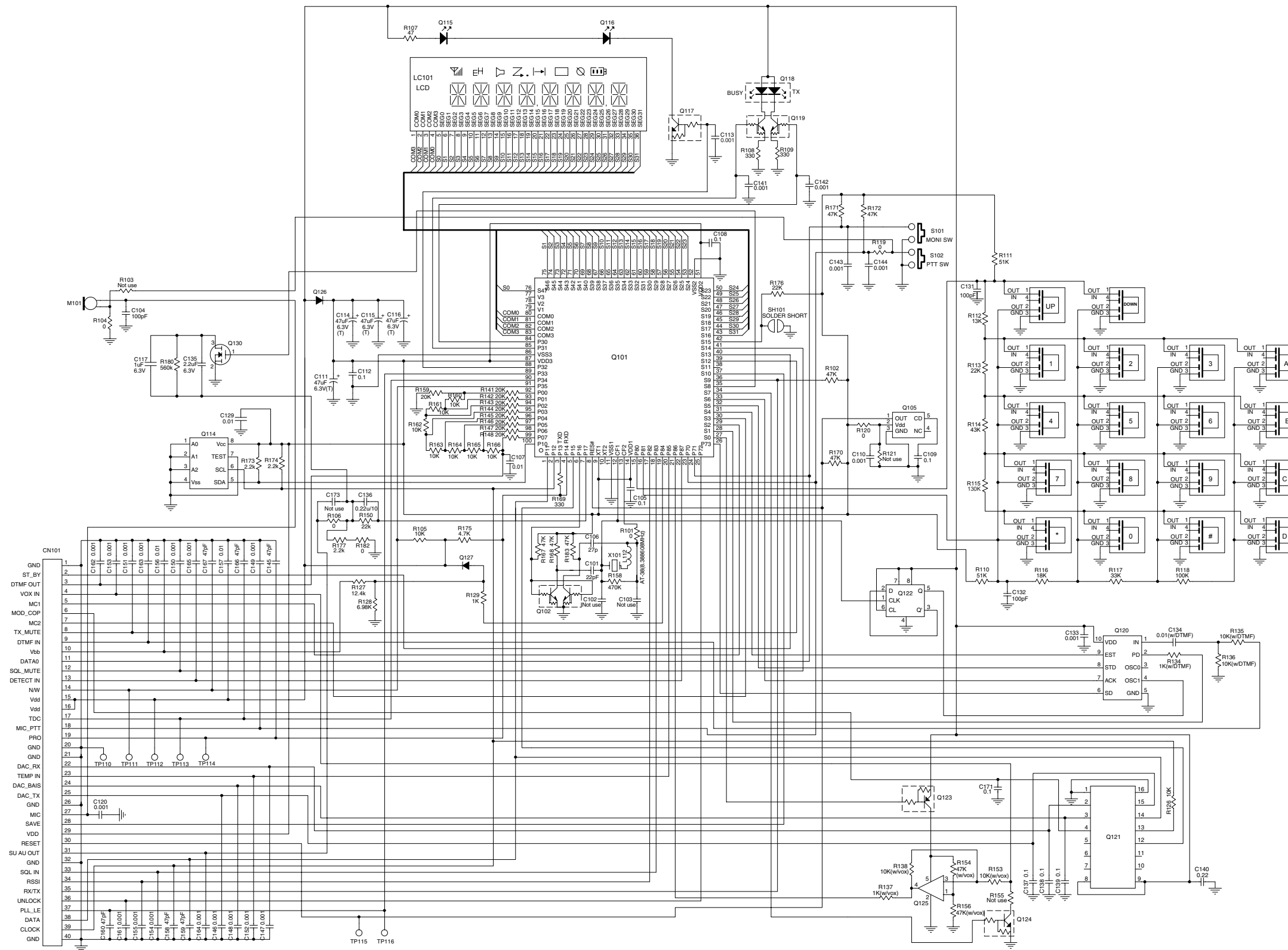

Figure 8-14. UHF 403-440 MHz Controller Board Schematic

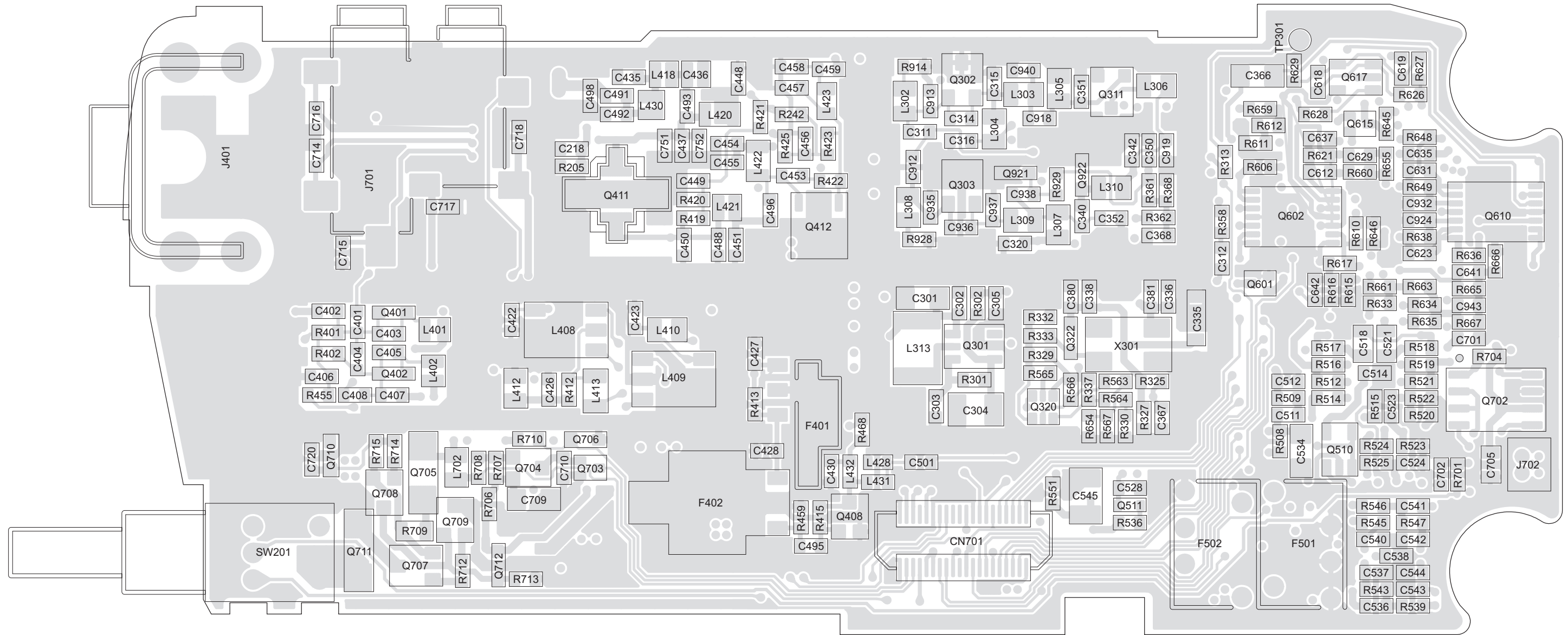

Figure 8-15. UHF 403-440 MHz Main Board Top Side

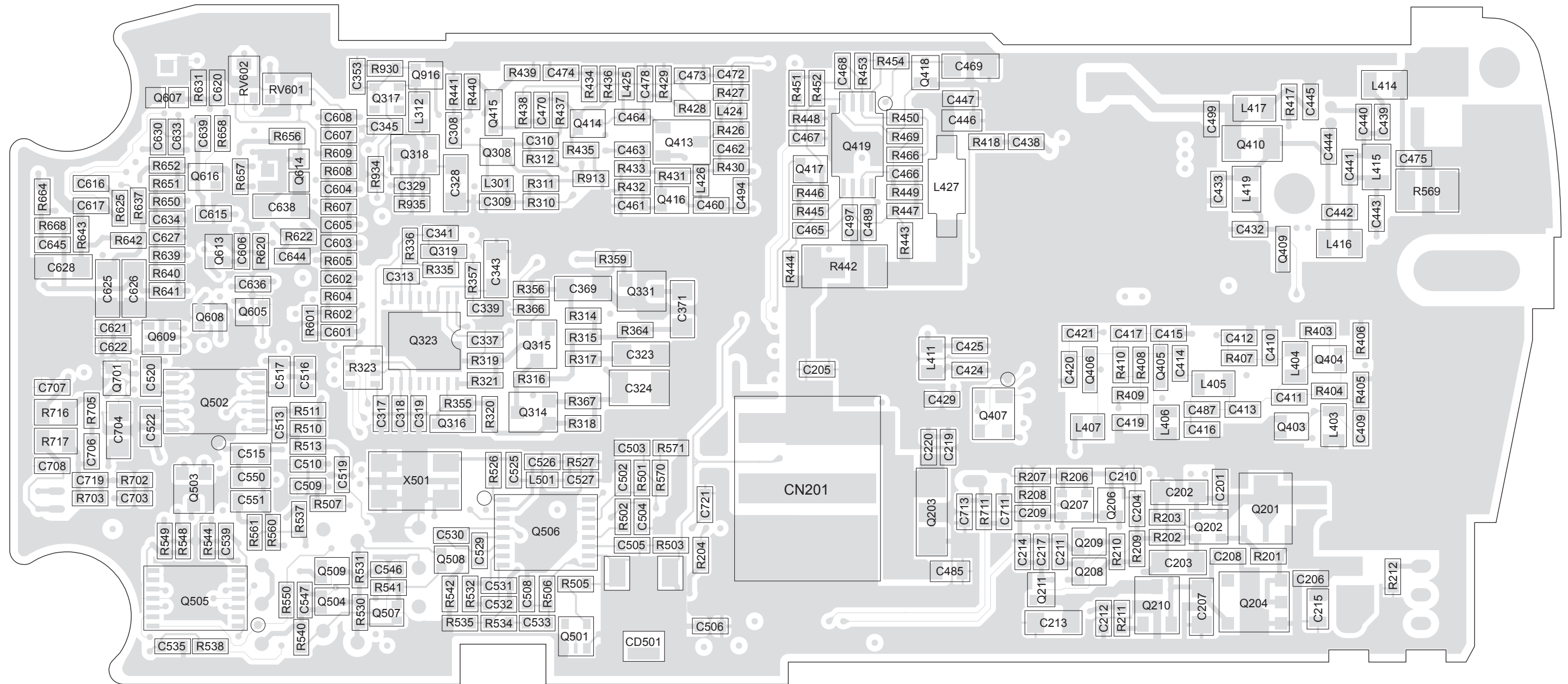

Figure 8-16. UHF 403-440 MHz Main Board Bottom Side

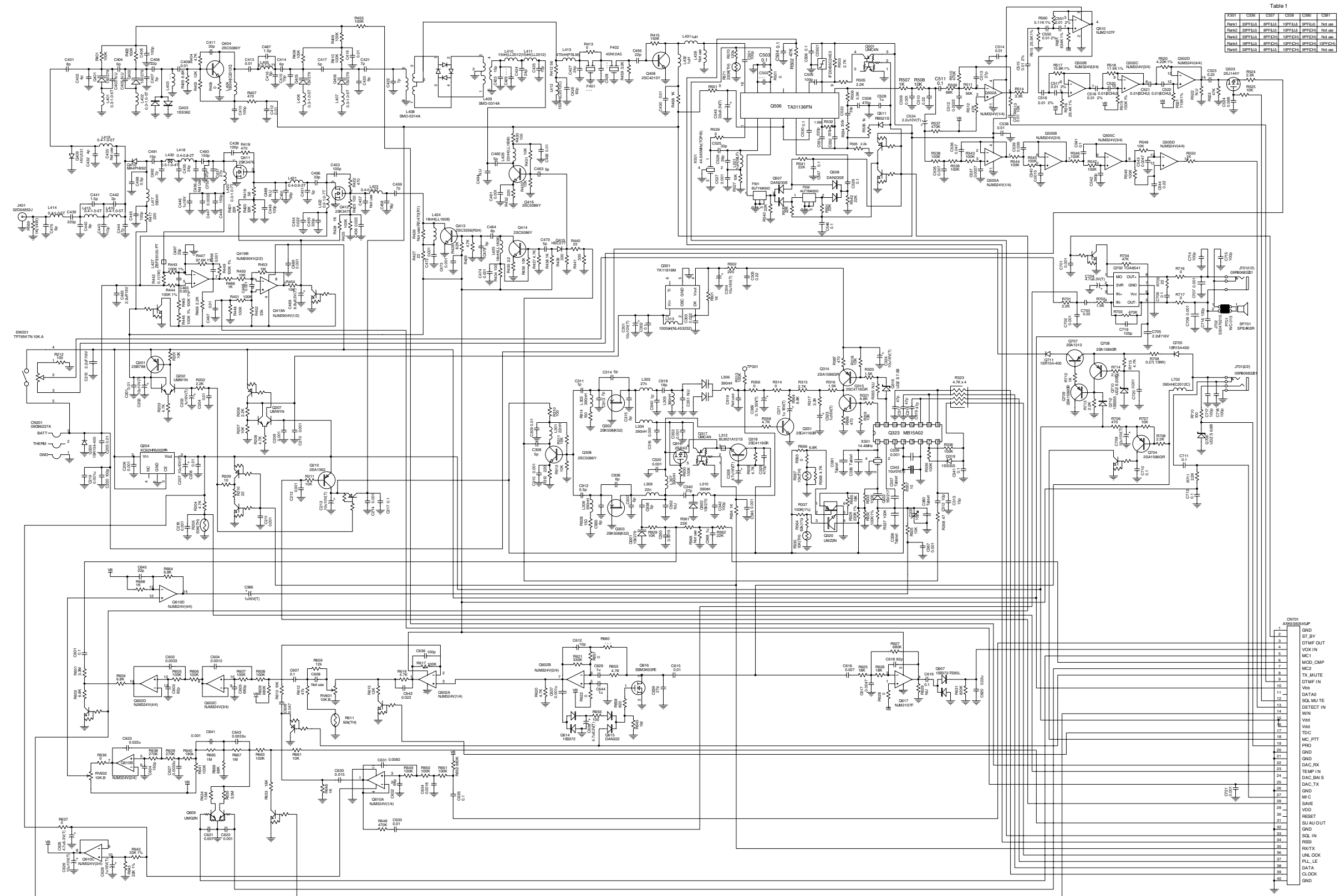

Table 1

Q101	Q102	Q103	Q104	Q105	Q106	Q107	Q108	Q109	Q110	Q111	Q112	Q113	Q114
Q101	Q102	Q103	Q104	Q105	Q106	Q107	Q108	Q109	Q110	Q111	Q112	Q113	Q114
Q101	Q102	Q103	Q104	Q105	Q106	Q107	Q108	Q109	Q110	Q111	Q112	Q113	Q114
Q101	Q102	Q103	Q104	Q105	Q106	Q107	Q108	Q109	Q110	Q111	Q112	Q113	Q114
Q101	Q102	Q103	Q104	Q105	Q106	Q107	Q108	Q109	Q110	Q111	Q112	Q113	Q114

Figure 8-17. UHF 403-440 MHz RF Schematics Diagram

## UHF 403-440 MHz Radio Parts List (Controller Board)

Circuit Ref	Description	Vendor	Vendor Part Number	Motorola Equivalent Part Number
C101	22pF; 50V; +-5%	Murata	GRM39CH220J50PT	2113740F35
C102	NU			
C103	10pF; 50V; +-5%	Murata	GRM39CH100J50PT	N/A
C104	100pF; 50V; +-5%	Murata	GRM39CH101J50PT	2113740F51
C105	0.1uF; 16V; +-10%	Murata	GRM39B104K16PT	N/A
C106	27pF; 50V; +-5%	Murata	GRM39CH270J50PT	2113740F37
C107	0.01uF; 50V; +-10%	Murata	GRM39B103K50PT	N/A
C108	0.1uF; 16V; +-10%	Murata	GRM39B104K16PT	N/A
C109	0.1uF; 16V; +-10%	Murata	GRM39B104K16PT	N/A
C110	0.001uF; 50V; +-10%	Murata	GRM39B102K50PT	N/A
C111	47uF;6.3V;+-20%	NI-CHEMI	6MCM476MB2TER	N/A
C112	0.1uF; 16V; +-10%	Murata	GRM39B104K16PT	N/A
C113	0.001uF; 50V; +-10%	Murata	GRM39B102K50PT	N/A
C114	47uF;6.3V;+-20%	NI-CHEMI	6MCM476MB2TER	N/A
C115	47uF;6.3V;+-20%	NI-CHEMI	6MCM476MB2TER	N/A
C116	47uF;6.3V;+-20%	NI-CHEMI	6MCM476MB2TER	N/A
C117	NU			
C120	0.001uF; 50V; +-10%	Murata	GRM39B102K50PT	N/A
C129	0.01uF; 50V; +-10%	Murata	GRM39B103K50PT	N/A
C131	33pF; 50V; +-5%	Murata	GRM39CH330J50PT	2113740F39
C132	33pF; 50V; +-5%	Murata	GRM39CH330J50PT	2113740F39
C133	0.001uF; 50V; +-10%	Murata	GRM39B102K50PT	N/A
C134	0.01uF; 50V; +-10%	Murata	GRM39B103K50PT	N/A
C135	2.2pF; 6.3V	Murata	GRM40B225K6.3PT	N/A
C136	NU			
C137	0.1uF; 16V; +-10%	Murata	GRM39B104K16PT	N/A
C138	0.1uF; 16V; +-10%	Murata	GRM39B104K16PT	N/A
C139	0.1uF; 16V; +-10%	Murata	GRM39B104K16PT	N/A
C140	0.22uF; 10V; +-10%	Murata	GRM39B224K10PT	2113928G01
C141	0.001uF; 50V; +-10%	Murata	GRM39B102K50PT	N/A
C142	0.001uF; 50V; +-10%	Murata	GRM39B102K50PT	N/A
C143	0.001uF; 50V; +-10%	Murata	GRM39B102K50PT	N/A
C144	0.001uF; 50V; +-10%	Murata	GRM39B102K50PT	N/A
C145	47pF; 50V; +-5%	Murata	GRM39CH470J50PT	2113740F43
C146	0.001uF; 50V; +-10%	Murata	GRM39B102K50PT	N/A
C147	0.001uF; 50V; +-10%	Murata	GRM39B102K50PT	N/A
C148	0.001uF; 50V; +-10%	Murata	GRM39B102K50PT	N/A
C149	0.001uF; 50V; +-10%	Murata	GRM39B102K50PT	N/A
C150	0.001uF; 50V; +-10%	Murata	GRM39B102K50PT	N/A
C151	0.001uF; 50V; +-10%	Murata	GRM39B102K50PT	N/A
C152	0.001uF; 50V; +-10%	Murata	GRM39B102K50PT	N/A
C153	0.001uF; 50V; +-10%	Murata	GRM39B102K50PT	N/A
C154	0.001uF; 50V; +-10%	Murata	GRM39B102K50PT	N/A
C155	0.001uF; 50V; +-10%	Murata	GRM39B102K50PT	N/A
C156	0.01uF; 50V; +-10%	Murata	GRM39B103K50PT	N/A
C157	0.01uF; 50V; +-10%	Murata	GRM39B103K50PT	N/A
C158	47pF; 50V; +-5%	Murata	GRM39CH470J50PT	2113740F43
C159	47pF; 50V; +-5%	Murata	GRM39CH470J50PT	2113740F43
C160	47pF; 50V; +-5%	Murata	GRM39CH470J50PT	2113740F43

Circuit Ref	Description	Vendor	Vendor Part Number	Motorola Equivalent Part Number
C161	0.001uF; 50V; +-10%	Murata	GRM39B102K50PT	N/A
C162	0.001uF; 50V; +-10%	Murata	GRM39B102K50PT	N/A
C163	0.001uF; 50V; +-10%	Murata	GRM39B102K50PT	N/A
C164	0.01uF; 50V; +-10%	Murata	GRM39B103K50PT	N/A
C165	0.001uF; 50V; +-10%	Murata	GRM39B102K50PT	N/A
C166	47pF; 50V; +-5%	Murata	GRM39CH470J50PT	2113740F43
C167	47pF; 50V; +-5%	Murata	GRM39CH470J50PT	2113740F43
C171	0.1uF; 16V; +-10%	Murata	GRM39B104K16PT	N/A
C173	NU			
C174	1uF; 6.3V; +-10%	Murata	GRM39B105K6.3PT	2113928P04
C175	0.01uF; 50V; +-10%	Murata	GRM39B103K50PT	N/A
C176	0.1uF; 16V; +-10%	Murata	GRM39B104K16PT	N/A
C181	0.22uF; 10V; +-10%	Murata	GRM39B224K10PT	2113928G01
C182	0.22uF; 10V; +-10%	Murata	GRM39B224K10PT	2113928G01
C183	470pF; 50V; +-5%	Murata	GRM39CH471J50PT	N/A
C191	0.001uF; 50V; +-10%	Murata	GRM39B102K50PT	N/A
CN101	Connector	Matsushita	AXK5S40245J/P	DSCN097002
L112	10uH	Taiyo Uden	LEM2520T100J	N/A
LC101	LCD	Picvue	HT138ZAS	DSL170003
M101	Capacitor Microphone	Bosung	OB-22P44	DSMI505001
PB101	CONTROL-PCB	Shikibo	K001C802-12	N/A
Q101	CPU	Sanyo	LC87F72C8A	DSIC092009
Q102	Dual NPN	Rohm	UMG2N TR	N/A
Q105	IC, CPU Reset	Rico	RN5VD30CATR	DSIC076007
Q114	IC, EEPROM	Seiko El.	S-24C16AFJ-01	DSIC510003
Q115	LED	Citizen	CL-200G-C-TS	N/A
Q116	LED	Citizen	CL-200G-C-TS	N/A
Q117	NPN	Rohm	DTC114EETL	N/A
Q118	Green/Red/Amber	Rohm	SML-020MLT T86NN	4804810T02
Q119	Dual NPN	Rohm	UMH6N TR	4880439V02
Q120	IC, DTMF Decoder	Sanyo	LC73881M	DSIC092007
Q121	IC, D/A Converter	Fujitsu	MB88347PFV	DSIC042002
Q122	IC, D Flip-flop	Toshiba	TC7W74FU TE12L	DSIC013029
Q123	PNP	Rohm	DTA144EETL	N/A
Q124	NU			
Q125	IC, Op-Amp	JRC	NJM2107F (TE1)	DSIC025016
Q126	Single	Rohm	RB521S-30 TE61	4805656W22
Q127	Diode	Rohm	1SS355 TE-17	4870360C15
Q130	FET	Toshiba	SSM3K03FE-TE85L	N/A
Q131	Diode	Toshiba	1SS372-TE85L	N/A
R101	0 ohm; 0.1W; +-5%	Rohm	MCR03 EZHJ 000	0662057B47
R102	47 Kohm; 0.1W; +-5%	Rohm	MCR03 EZHJ 473	0662057A89
R103	NU			
R104	0 ohm; 0.1W; +-5%	Rohm	MCR03 EZHJ 000	0662057B47
R105	10 Kohm; 0.1W; +-5%	Rohm	MCR03 EZHJ 103	0662057A73
R106	0 ohm; 0.1W; +-5%	Rohm	MCR03 EZHJ 000	0662057B47
R107	47 ohm; 0.1W; +-5%	Rohm	MCR03 EZHJ 470	0662057A17
R108	330 ohm; 0.1W; +-5%	Rohm	MCR03 EZHJ 331	0662057A37
R109	330 ohm; 0.1W; +-5%	Rohm	MCR03 EZHJ 331	0662057A37
R110	51 Kohm; 0.1W; +-5%	Rohm	MCR03 EZHJ 513	0662057A90
R111	51 Kohm; 0.1W; +-5%	Rohm	MCR03 EZHJ 513	0662057A90

Circuit Ref	Description	Vendor	Vendor Part Number	Motorola Equivalent Part Number
R112	13 Kohm; 0.1W; +-5%	Rohm	MCR03 EZHJ 133	0662057A76
R113	22 Kohm; 0.1W; +-5%	Rohm	MCR03 EZHJ 223	0662057A81
R114	43 Kohm; 0.1W; +-5%	Rohm	MCR03 EZHJ 433	0665027A88
R115	130 Kohm; 0.1W; +-5%	Rohm	MCR03 EZHJ 134	0662257B01
R116	18 Kohm; 0.1W; +-5%	Rohm	MCR03 EZHJ 183	0662057A79
R117	33 Kohm; 0.1W; +-5%	Rohm	MCR03 EZHJ 333	0662057A85
R118	100 Kohm; 0.1W; +-5%	Rohm	MCR03 EZHJ 104	0662057A97
R119	0 ohm; 0.1W; +-5%	Rohm	MCR03 EZHJ 000	0662057B47
R120	0 ohm; 0.1W; +-5%	Rohm	MCR03 EZHJ 000	0662057B47
R121	NU			
R126	10 Kohm; 0.1W; +-5%	Rohm	MCR03 EZHJ 103	0662057A73
R127	12.4 Kohm; 0.1W; +-1%	Rohm	MCR03 EZHF 1242	0662057P69
R128	6.98 Kohm; 0.1W; +-1%	Rohm	MCR03 EZHF 6981	0662057Y24
R129	1 Kohm; 0.1W; +-5%	Rohm	MCR03 EZHJ 102	0662057A49
R134	1 Kohm; 0.1W; +-5%	Rohm	MCR03 EZHJ 102	0662057A49
R135	10 Kohm; 0.1W; +-5%	Rohm	MCR03 EZHJ 103	0662057A73
R136	10 Kohm; 0.1W; +-5%	Rohm	MCR03 EZHJ 103	0662057A73
R137	1 Kohm; 0.1W; +-5%	Rohm	MCR03 EZHJ 102	0662057A49
R138	100 Kohm; 0.1W; +-5%	Rohm	MCR03 EZHJ 104	0662057A97
R141	20 Kohm; 0.1W; +-5%	Rohm	MCR03 EZHJ 203	0662057A80
R142	20 Kohm; 0.1W; +-5%	Rohm	MCR03 EZHJ 203	0662057A80
R143	20 Kohm; 0.1W; +-5%	Rohm	MCR03 EZHJ 203	0662057A80
R144	20 Kohm; 0.1W; +-5%	Rohm	MCR03 EZHJ 203	0662057A80
R145	20 Kohm; 0.1W; +-5%	Rohm	MCR03 EZHJ 203	0662057A80
R146	20 Kohm; 0.1W; +-5%	Rohm	MCR03 EZHJ 203	0662057A80
R147	20 Kohm; 0.1W; +-5%	Rohm	MCR03 EZHJ 203	0662057A80
R148	20 Kohm; 0.1W; +-5%	Rohm	MCR03 EZHJ 203	0662057A80
R150	2.2 Kohm; 0.1W; +-5%	Rohm	MCR03 EZHJ 222	0662057A57
R153	10 Kohm; 0.1W; +-5%	Rohm	MCR03 EZHJ 103	0662057A73
R154	47 Kohm; 0.1W; +-5%	Rohm	MCR03 EZHJ 473	0662057A89
R155	NU			
R156	47 Kohm; 0.1W; +-5%	Rohm	MCR03 EZHJ 473	0662057A89
R157	220 Kohm; 0.1W; +-5%	Rohm	MCR03 EZHJ 224	N/A
R158	470 Kohm; 0.1W; +-5%	Rohm	MCR03 EZHJ 474	0662057B14
R159	20 Kohm; 0.1W; +-5%	Rohm	MCR03 EZHJ 203	0662057A80
R160	10 Kohm; 0.1W; +-5%	Rohm	MCR03 EZHJ 103	0662057A73
R161	10 Kohm; 0.1W; +-5%	Rohm	MCR03 EZHJ 103	0662057A73
R162	10 Kohm; 0.1W; +-5%	Rohm	MCR03 EZHJ 103	0662057A73
R163	10 Kohm; 0.1W; +-5%	Rohm	MCR03 EZHJ 103	0662057A73
R164	10 Kohm; 0.1W; +-5%	Rohm	MCR03 EZHJ 103	0662057A73
R165	10 Kohm; 0.1W; +-5%	Rohm	MCR03 EZHJ 103	0662057A73
R166	10 Kohm; 0.1W; +-5%	Rohm	MCR03 EZHJ 103	0662057A73
R167	47 Kohm; 0.1W; +-5%	Rohm	MCR03 EZHJ 473	0662057A89
R168	47 Kohm; 0.1W; +-5%	Rohm	MCR03 EZHJ 473	0662057A89
R169	330 ohm; 0.1W; +-5%	Rohm	MCR03 EZHJ 331	0662057A37
R170	47 Kohm; 0.1W; +-5%	Rohm	MCR03 EZHJ 473	0662057A89
R171	47 Kohm; 0.1W; +-5%	Rohm	MCR03 EZHJ 473	0662057A89
R172	47 Kohm; 0.1W; +-5%	Rohm	MCR03 EZHJ 473	0662057A89
R173	2.2 Kohm; 0.1W; +-5%	Rohm	MCR03 EZHJ 222	0662057A57
R174	2.2 Kohm; 0.1W; +-5%	Rohm	MCR03 EZHJ 222	0662057A57
R175	4.7 Kohm; 0.1W; +-5%	Rohm	MCR03 EZHJ 472	0662057A65

Circuit Ref	Description	Vendor	Vendor Part Number	Motorola Equivalent Part Number
R176	22 Kohm; 0.1W; +-5%	Rohm	MCR03 EZHJ 223	0662057A81
R177	NU			
R180	10 Kohm; 0.1W; +-5%	Rohm	MCR03 EZHJ 103	0662057A73
R182	0 ohm; 0.1W; +-5%	Rohm	MCR10 EZHJ 000	N/A
R183	47 Kohm; 0.1W; +-5%	Rohm	MCR03 EZHJ 473	0662057A89
R184	10 Kohm; 0.1W; +-5%	Rohm	MCR03 EZHJ 103	0662057A73
R185	470 ohm; 0.1W; +-5%	Rohm	MCR03 EZHJ 471	0662057A41
R186	0 ohm; 0.1W; +-5%	Rohm	MCR03 EZHJ 000	0662057B47
S101	Tact Switch	Motorola	Y39A33110FP	4080523Z01
S102	Tact Switch	Motorola	Y39A33110FP	4080523Z01
X101	Filter, 8.388608 MHz	Daishinkuu	AT-38	DSXT182001

## UHF 403-440 MHz Radio Parts List (RF Board)

Circuit Ref	Description	Vendor	Vendor Part Number	Motorola Equivalent Part Number
	<b>CAPACITOR</b>			
C201	0.01uF; 50V; +-10%	Murata	GRM39B103K50PT	N/A
C202	10uF 10V	NI-CHEMI	10MCM106MATER	N/A
C203	1uF 16V	NI-CHEMI	16MC105MATER	N/A
C204	0.01uF; 50V; +-10%	Murata	GRM39B103K50PT	N/A
C205	0.01uF; 50V; +-10%	Murata	GRM39B103K50PT	N/A
C206	0.001uF; 50V; +-10%	Murata	GRM39B102K50PT	N/A
C207	10uF 10V	NI-CHEMI	10MCM106MATER	N/A
C208	0.01uF; 50V; +-10%	Murata	GRM39B103K50PT	N/A
C209	0.001uF; 50V; +-10%	Murata	GRM39B102K50PT	N/A
C210	0.001uF; 50V; +-10%	Murata	GRM39B102K50PT	N/A
C211	0.001uF; 50V; +-10%	Murata	GRM39B102K50PT	N/A
C212	0.001uF; 50V; +-10%	Murata	GRM39B102K50PT	N/A
C213	10uF 10V	NI-CHEMI	10MCM106MATER	N/A
C214	0.001uF; 50V; +-10%	Murata	GRM39B102K50PT	N/A
C215	2.2uF; 16V; +80% -20%	Murata	GRM40F225Z16PT	N/A
C217	0.1uF; 16V; +-10%	Murata	GRM39B104K16PT	N/A
C218	0.001uF; 50V; +-10%	Murata	GRM39B102K50PT	N/A
C219	0.001uF; 50V; +-10%	Murata	GRM39B102K50PT	N/A
C220	100pF; 50V; +-5%	Murata	GRM39CH101J50PT	2113740F51
C301	10uF 10V	NI-CHEMI	10MCM106MATER	N/A
C302	0.1uF; 16V; +-10%	Murata	GRM39B104K16PT	N/A
C303	0.022uF; 50V; +-10%	Murata	GRM39B223K25PT	N/A
C304	10uF; 16V	Ni-Chemi	16MCM106MB2TER	N/A
C305	0.22uF; 10V; +-10%	Murata	GRM39B224K10PT	2113928G05
C306	NU			
C307	NU			
C308	5pF; 50V; +-0.25pF	Murata	GRM39CH050C50PT	N/A
C309	0.01uF; 50V; +-10%	Murata	GRM39B103K50PT	N/A
C310	0.001uF; 50V; +-10%	Murata	GRM39B102K50PT	N/A
C311	1pF; 50V; +-5%	Murata	GRM39CK010C50PT	N/A
C312	10pF; 50V; +-0.5pF	Murata	GRM39CH100D50PT	2113740F27
C313	15pF; 50V; +-5%	Murata	GRM39CH150J50PT	2113740F31
C314	5pF; 50V; +-0.25pF	Murata	GRM39CH050C50PT	N/A
C315	5pF; 50V; +-0.25pF	Murata	GRM39CH050C50PT	N/A
C316	0.001uF; 50V; +-10%	Murata	GRM39B102K50PT	N/A
C317	47pF; 50V; +-5%	Murata	GRM39CH470J50PT	2113740F43
C318	47pF; 50V; +-5%	Murata	GRM39CH470J50PT	2113740F43
C319	47pF; 50V; +-5%	Murata	GRM39CH470J50PT	2113740F43
C320	0.001uF; 50V; +-10%	Murata	GRM39B102K50PT	N/A
C323	1uF 16V	NI-CHEMI	16MC105MATER	N/A
C324	10uF; 16V	Ni-Chemi	16MCM106MB2TER	N/A
C328	4.7uF 16V	NI-CHEMI	16MCM475MATER	N/A
C329	470pF; 50V; +-10%	Murata	GRM39B471K50PT	N/A
C335	10pF	Murata	TZV02Z100A110T00	N/A
C336	33pF; 50V; +-5%	Murata	GRM39UJ330J50PT	N/A
C337	8pF; 50V ; +-0.5pF	Murata	GRM39UJ080D50PT	N/A
C338	10pF; 50V; +-0.5pF	Murata	GRM39UJ100D50PT	N/A
C339	0.001uF; 50V; +-10%	Murata	GRM39B102K50PT	N/A

Circuit Ref	Description	Vendor	Vendor Part Number	Motorola Equivalent Part Number
C340	15pF; 50V; +-5%	Murata	GRM39CH150J50PT	2113740F31
C341	0.1uF; 16V; +-10%	Murata	GRM39B104K16PT	N/A
C342	100pF; 50V; +-5%	Murata	GRM39CH101J50PT	2113740F51
C343	10uF 10V	NI-CHEMI	10MCM106MATER	N/A
C345	0.001uF; 50V; +-10%	Murata	GRM39B102K50PT	N/A
C347	0.001uF; 50V; +-10%	Murata	GRM39B102K50PT	N/A
C350	0.0015uF; 50V; +-10%	Murata	GRM39B152K50PT	N/A
C351	NU			
C352	2pF; 50V; +-10%	Murata	GRM39CH020C50PT	N/A
C353	0.001uF; 50V; +-10%	Murata	GRM39B102K50PT	N/A
C366	4.7uF 16V	NI-CHEMI	16MCM475MATER	N/A
C367	0.001uF; 50V; +-10%	Murata	GRM39B102K50PT	N/A
C368	1uF; 6.3V; +-10%	Murata	GRM39B105K6.3PT	2113928P04
C369	0.1uF; 35V	NI-CHEMI	35MC104MATER	N/A
C371	1uF 16V	NI-CHEMI	16MC105MATER	N/A
C380	9pF; 50V; +-0.5pF	Murata	GRM39CH090D50PT	N/A
C381	NU			
C401	8pF; 50V; +-0.5pF	Murata	GRM39CH080D50PT	N/A
C402	4pF; 50V; +-0.25pF	Murata	GRM39CH040C50PT	N/A
C403	NU			
C404	6pF; 50V; +-0.25pF	Murata	GRM39CH060C50PT	N/A
C405	NU			
C406	100pF; 50V; +-5%	Murata	GRM39CH101J50PT	2113740F51
C407	5pF; 50V; +-5%	Murata	GRM39CK050C50PT	N/A
C408	22pF; 50V; +-5%	Murata	GRM39CH220J50PT	2113740F35
C409	0.01uF; 50V; +-10%	Murata	GRM39B103K50PT	N/A
C410	100pF; 50V; +-5%	Murata	GRM39CH101J50PT	2113740F51
C411	33pF; 50V; +-5%	Murata	GRM39CH330J50PT	2113740F39
C412	0.01uF; 50V; +-10%	Murata	GRM39B103K50PT	N/A
C413	0.01uF; 50V; +-10%	Murata	GRM39B103K50PT	N/A
C414	6pF; 50V; +-0.25pF	Murata	GRM39CH060C50PT	N/A
C415	10pF; 50V; +-0.5pF	Murata	GRM39CH100D50PT	2113740F27
C416	6pF; 50V; +-0.25pF	Murata	GRM39CH060C50PT	N/A
C417	4pF; 50V; +-0.25pF	Murata	GRM39CH040C50PT	N/A
C419	0.01uF; 50V; +-10%	Murata	GRM39B103K50PT	N/A
C420	9pF; 50V; +-0.5pF	Murata	GRM39CH090D50PT	N/A
C421	7pF; 50V; +-0.5pF	Murata	GRM39CH070D50PT	N/A
C422	7pF; 50V; +-0.5pF	Murata	GRM39CH070D50PT	N/A
C423	15pF; 50V; +-5%	Murata	GRM39CH150J50PT	2113740F31
C424	24pF; 50V; +-5%	Murata	GRM39CH240J50PT	2113740F36
C425	10pF; 50V; +-0.5pF	Murata	GRM39CH100D50PT	2113740F27
C426	82pF; 50V; +-5%	Murata	GRM39CH820J50PT	2113740F49
C427	24pF; 50V; +-5%	Murata	GRM39CH240J50PT	2113740F36
C428	NU			
C429	NU			
C430	0.01uF; 50V; +-10%	Murata	GRM39B103K50PT	N/A
C432	4pF; 50V; +-0.25pF	Murata	GRM39CH040C50PT	N/A
C433	NU			
C435	24pF; 50V; +-5%	Murata	GRM39CH240J50PT	2113740F36
C436	NU			
C437	27pF; 50V; +-5%	Murata	GRM39CH270J50PT	2113740F37



Circuit Ref	Description	Vendor	Vendor Part Number	Motorola Equivalent Part Number
C438	100pF; 50V; +-5%	Murata	GRM39CH101J50PT	2113740F51
C439	220pF; 50V; +-10%	Murata	GRM39B221K50PT	N/A
C440	9pF; 50V; +-0.5pF	Murata	GRM39CH090D50PT	N/A
C441	1.5pF; 50V; +-5%	Murata	GRM39CK1R5C50PT	N/A
C442	2pF; 50V; +-5%	Murata	GRM39CK020C50PT	N/A
C443	10pF; 50V; +-0.5pF	Murata	GRM39CH100D50PT	2113740F27
C444	7pF; 50V; +-0.5pF	Murata	GRM39CH070D50PT	N/A
C445	100pF; 50V; +-5%	Murata	GRM39CH101J50PT	2113740F51
C446	1uF; 16V; +-10%	Murata	GRM40B105K16PT	N/A
C447	0.0033uF; 50V; +-10%	Murata	GRM39B332K50PT	2155169M15
C448	150pF; 50V; +-5%	Murata	GRM39CH151J50PT	2113740F55
C449	100pF; 50V; +-5%	Murata	GRM39CH101J50PT	2113740F51
C450	56pF; 50V; +-5%	Murata	GRM39CH560J50PT	2113740F45
C451	10pF; 50V; +-0.5pF	Murata	GRM39CH100D50PT	2113740F27
C453	100pF; 50V; +-5%	Murata	GRM39CH101J50PT	2113740F51
C454	0.022uF; 50V; +-10%	Murata	GRM39B223K25PT	N/A
C455	330pF; 50V; +-10%	Murata	GRM39B331K50PT	N/A
C456	1uF; 16V; +-10%	Murata	GRM40B105K16PT	N/A
C457	NU			
C458	18pF; 50V; +-5%	Murata	GRM39CH180J50PT	2113740F33
C459	7pF; 50V; +-0.5pF	Murata	GRM39CH070D50PT	N/A
C460	5pF; 50V; +-0.25pF	Murata	GRM39CH050C50PT	N/A
C461	0.001uF; 50V; +-10%	Murata	GRM39B102K50PT	N/A
C462	0.01uF; 50V; +-10%	Murata	GRM39B103K50PT	N/A
C463	5pF; 50V; +-0.25pF	Murata	GRM39CH050C50PT	N/A
C464	8pF; 50V; +-0.5pF	Murata	GRM39CH080D50PT	N/A
C465	NU			
C466	0.001uF; 50V; +-10%	Murata	GRM39B102K50PT	N/A
C467	0.01uF; 50V; +-10%	Murata	GRM39B103K50PT	N/A
C468	0.001uF; 50V; +-10%	Murata	GRM39B102K50PT	N/A
C469	6.8uF; 6.3V	NI-CHEMI	6MCS685MATER	N/A
C470	5pF; 50V; +-0.25pF	Murata	GRM39CH050C50PT	N/A
C472	0.001uF; 50V; +-10%	Murata	GRM39B102K50PT	N/A
C473	0.001uF; 50V; +-10%	Murata	GRM39B102K50PT	N/A
C474	0.001uF; 50V; +-10%	Murata	GRM39B102K50PT	N/A
C475	6pF; 50V; +-0.25pF	Murata	GRM39CH060C50PT	N/A
C478	5pF; 50V; +-0.25pF	Murata	GRM39CH050C50PT	N/A
C485	2.2uF; 16V; +80% -20%	Murata	GRM40F225Z16PT	N/A
C487	2.5pF; 50V; +-10%	Murata	GRM39CK2R5C50PT	N/A
C488	NU			
C489	0.001uF; 50V; +-10%	Murata	GRM39B102K50PT	N/A
C490	NU			
C491	22pF; 50V; +-5%	Murata	GRM39CH220J50PT	2113740F35
C492	5pF; 50V; +-0.25pF	Murata	GRM39CH050C50PT	N/A
C493	150pF; 50V; +-5%	Murata	GRM39CH151J50PT	2113740F55
C494	NU			
C495	22pF; 50V; +-5%	Murata	GRM39CH220J50PT	2113740F35
C496	33pF; 50V; +-5%	Murata	GRM39CH330J50PT	2113740F39
C497	22pF; 50V; +-5%	Murata	GRM39CH220J50PT	2113740F35
C498	0.5pF; 50V; +-5%	Murata	GRM39CH0R5C50PT	N/A
C501	100pF; 50V; +-5%	Murata	GRM39CH101J50PT	2113740F51

Circuit Ref	Description	Vendor	Vendor Part Number	Motorola Equivalent Part Number
C502	NU			
C503	0.1uF; 16V; +-10%	Murata	GRM39B104K16PT	N/A
C504	0.1uF; 16V; +-10%	Murata	GRM39B104K16PT	N/A
C505	100pF; 50V; +-5%	Murata	GRM39CH101J50PT	2113740F51
C506	0.1uF; 16V; +-10%	Murata	GRM39B104K16PT	N/A
C508	470pF; 50V; +-10%	Murata	GRM39B471K50PT	N/A
C509	0.001uF; 50V; +-10%	Murata	GRM39B102K50PT	N/A
C510	0.22uF; 10V; +-10%	Murata	GRM39B224K10PT	2113928G05
C511	0.1uF; 16V; +-10%	Murata	GRM39B104K16PT	N/A
C512	0.0022uF; 50V; +-10%	Murata	GRM39B222K50PT	N/A
C513	27pF; 50V; +-5%	Murata	GRM39CH270J50PT	2113740F37
C514	0.01uF; 50V; +-10%	Murata	GRM39B103K50PT	N/A
C515	0.01uF; 16V; +-2%	Panasonic	ECHU1C103GX5	N/A
C516	0.01uF; 16V; +-2%	Panasonic	ECHU1C103GX5	N/A
C517	0.01uF; 16V; +-2%	Panasonic	ECHU1C103GX5	N/A
C518	0.01uF; 16V; +-2%	Panasonic	ECHU1C103GX5	N/A
C519	0.01uF; 50V; +-10%	Murata	GRM39B103K50PT	N/A
C520	0.01uF; 16V; +-2%	Panasonic	ECHU1C103GX5	N/A
C521	0.01uF; 16V; +-2%	Panasonic	ECHU1C103GX5	N/A
C522	0.01uF; 16V; +-2%	Panasonic	ECHU1C103GX5	N/A
C523	0.22uF; 10V; +-10%	Murata	GRM39B224K10PT	2113928G05
C524	0.068uF; 16V; +-10%	Murata	GRM39B683K16PT	N/A
C525	33pF; 50V; +-5%	Murata	GRM39CH330J50PT	2113740F39
C526	39pF; 50V; +-5%	Murata	GRM39CH390J50PT	2113740F41
C527	0.001uF; 50V; +-10%	Murata	GRM39B102K50PT	N/A
C528	1uF; 6.3V; +-10%	Murata	GRM39B105K6.3PT	2113928P04
C529	0.1uF; 16V; +-10%	Murata	GRM39B104K16PT	N/A
C530	0.1uF; 16V; +-10%	Murata	GRM39B104K16PT	N/A
C531	220pF; 50V; +-10%	Murata	GRM39B221K50PT	N/A
C532	220pF; 50V; +-5%	Murata	GRM39CH221J50PT	N/A
C533	56pF; 50V; +-5%	Murata	GRM39CH560J50PT	2113740F45
C534	2.2uF; 10V	NI-CHEMI	10MCS225MATER	N/A
C535	0.027uF; 25v; +-10%	Murata	GRM39B273K25PT	2155169N29
C536	0.047uF; 16V; +-10%	Murata	GRM39B473K16PT	N/A
C537	0.0027uF; 50V; +-10%	Murata	GRM39B272K50PT	N/A
C538	0.01uF; 50V; +-10%	Murata	GRM39B103K50PT	N/A
C539	0.039uF; 16v; +-10%	Murata	GRM39B393K16PT	N/A
C540	0.0015uF; 50V; +-10%	Murata	GRM39B152K50PT	N/A
C541	0.1uF; 16V; +-10%	Murata	GRM39B104K16PT	N/A
C542	390pF; 50V; +-10%	Murata	GRM39B391K50PT	2113741F15
C543	0.0047uF; 50V; +-10%	Murata	GRM39B472K50PT	N/A
C544	0.22uF; 10V; +-10%	Murata	GRM39B224K10PT	2113928G05
C545	33uF; 6.3V	NI-CHEMI	6MCM336MB2TER	N/A
C546	0.1uF; 16V; +-10%	Murata	GRM39B104K16PT	N/A
C547	0.1uF; 16V; +-10%	Murata	GRM39B104K16PT	N/A
C550	0.01uF; 16V; +-2%	Panasonic	ECHU1C103GX5	N/A
C551	0.01uF; 16V; +-2%	Panasonic	ECHU1C103GX5	N/A
C601	0.1uF; 16V; +-10%	Murata	GRM39B104K16PT	N/A
C602	0.0033uF; 50V; +-10%	Murata	GRM39B332K50PT	2155169M15
C603	82pF; 50V; +-5%	Murata	GRM39CH820J50PT	2113740F49
C604	0.0012uF; 50V; +-10%	Murata	GRM39B122K50PT	N/A

Circuit Ref	Description	Vendor	Vendor Part Number	Motorola Equivalent Part Number
C605	680pF; 50V; +10%	Murata	GRM39B681K50PT	N/A
C606	0.1uF; 16V; +-10%	Murata	GRM39B104K16PT	N/A
C607	0.1uF; 16V; +-10%	Murata	GRM39B104K16PT	N/A
C608	NU			
C612	10pF; 50V; +-0.5pF	Murata	GRM39CH100D50PT	2113740F27
C615	0.01uF; 50V; +-10%	Murata	GRM39B103K50PT	N/A
C616	0.027uF; 25v; +-10%	Murata	GRM39B273K25PT	2155169N29
C617	0.0047uF; 50V; +-10%	Murata	GRM39B472K50PT	N/A
C618	82pF; 50V; +-5%	Murata	GRM39CH820J50PT	2113740F49
C619	0.1uF; 16V; +-10%	Murata	GRM39B104K16PT	N/A
C620	NU			
C621	0.001uF; 50V; +-10%	Murata	GRM39B102K50PT	N/A
C622	0.001uF; 50V; +-10%	Murata	GRM39B102K50PT	N/A
C623	0.022uF; 50V; +-10%	Murata	GRM39B223K25PT	N/A
C624	150pF; 50V; +-5%	Murata	GRM39CH151J50PT	2113740F55
C625	4.7uF; 6.3V	NI-CHEMI	6MCS475MATER	N/A
C626	10uF 10V	NI-CHEMI	10MCM106MATER	N/A
C627	0.0033uF; 50V; +-10%	Murata	GRM39B332K50PT	2155169M15
C628	1uF 16V	NI-CHEMI	16MC105MATER	N/A
C629	1uF; 6.3V; +-10%	Murata	GRM39B105K6.3PT	2113928P04
C630	0.015uF; 50V; +-10%	Murata	GRM39B152K50PT	2113932E03
C631	0.0082uF; 50V; +-10%	Murata	GRM39B822K50PT	N/A
C632	68pF; 50V; +-5%	Murata	GRM39CH680J50PT	2113740F47
C633	0.01uF; 50V; +-10%	Murata	GRM39B103K50PT	N/A
C634	0.0018uF; 50V; +-10%	Murata	GRM39B182K50PT	2155116E54
C635	0.1uF; 16V; +-10%	Murata	GRM39B104K16PT	N/A
C636	100pF; 50V; +-5%	Murata	GRM39CH101J50PT	2113740F51
C637	0.001uF; 50V; +-10%	Murata	GRM39B102K50PT	N/A
C638	4.7uF; 6.3V	NI-CHEMI	6MCS475MATER	N/A
C639	27pF; 50V; +-5%	Murata	GRM39CH270J50PT	2113740F37
C641	0.0027uF; 50V; +-10%	Murata	GRM39B272K50PT	N/A
C642	0.022uF; 50V; +-10%	Murata	GRM39B223K25PT	N/A
C643	0.01uF; 50V; +-10%	Murata	GRM39B103K50PT	N/A
C644	1uF; 6.3V; +-10%	Murata	GRM39B105K6.3PT	2113928P04
C645	22pF; 50V; +-5%	Murata	GRM39CH220J50PT	2113740F35
C701	0.001uF; 50V; +-10%	Murata	GRM39B102K50PT	N/A
C702	0.001uF; 50V; +-10%	Murata	GRM39B102K50PT	N/A
C703	0.22uF; 10V; +-10%	Murata	GRM39B224K10PT	2113928G05
C704	4.7uF; 6.3V	NI-CHEMI	6MCS475MATER	N/A
C705	2.2uF; 16V; +80% -20%	Murata	GRM40F225Z16PT	N/A
C706	0.1uF; 16V; +-10%	Murata	GRM39B104K16PT	N/A
C707	0.001uF; 50V; +-10%	Murata	GRM39B102K50PT	N/A
C708	0.001uF; 50V; +-10%	Murata	GRM39B102K50PT	N/A
C709	10uF 10V	NI-CHEMI	10MCM106MATER	N/A
C710	0.1uF; 16V; +-10%	Murata	GRM39B104K16PT	N/A
C711	0.1uF; 16V; +-10%	Murata	GRM39B104K16PT	N/A
C713	0.1uF; 16V; +-10%	Murata	GRM39B104K16PT	N/A
C714	100pF; 50V; +-5%	Murata	GRM39CH101J50PT	2113740F51
C715	100pF; 50V; +-5%	Murata	GRM39CH101J50PT	2113740F51
C716	100pF; 50V; +-5%	Murata	GRM39CH101J50PT	2113740F51
C717	100pF; 50V; +-5%	Murata	GRM39CH101J50PT	2113740F51

Circuit Ref	Description	Vendor	Vendor Part Number	Motorola Equivalent Part Number
C718	100pF; 50V; +-5%	Murata	GRM39CH101J50PT	2113740F51
C719	220pF; 50V; +-5%	Murata	GRM39CH221J50PT	N/A
C720	0.001uF; 50V; +-10%	Murata	GRM39B102K50PT	N/A
C721	0.001uF; 50V; +-10%	Murata	GRM39B102K50PT	N/A
C752	27pF; 50V; +-5%	Murata	GRM39CH270J50PT	2113740F37
C912	0.5pF; 50V; +-5%	Murata	GRM39CK0R5C50PT	N/A
C913	7pF; 50V; +-0.5pF	Murata	GRM39CH070D50PT	N/A
C917	NU			
C918	18pF; 50V; +-5%	Murata	GRM39CH180J50PT	2113740F33
C919	0.022uF; 50V; +-10%	Murata	GRM39B223K25PT	N/A
C935	6pF; 50V; +-0.25pF	Murata	GRM39CH060C50PT	N/A
C936	6pF; 50V; +-0.25pF	Murata	GRM39CH060C50PT	N/A
C937	6pF; 50V; +-0.25pF	Murata	GRM39CH060C50PT	N/A
C938	2pF; 50V; +-10%	Murata	GRM39CH020C50PT	N/A
C939	NU			
C940	1pF; 50V; +-5%	Murata	GRM39CK010C50PT	N/A
	<b>TRANSISTOR:</b>			
Q201	PNP	NEC	2SB798-T1 DK	N/A
Q202	Digital transistor	Rohm	UMW1N TL	N/A
Q206	PNP	Rohm	DTA123YETL	N/A
Q207	Digital transistor	Rohm	UMW1N TL	N/A
Q208	PNP	Rohm	DTA114EETL	4808317Y01
Q209	Digital transistor	Rohm	DTC114EETL	N/A
Q210	PNP	Toshiba	2SA1362-GR TE85L	N/A
Q211	PNP	Rohm	DTA123YETL	N/A
Q302	FET	NEC	2SK508-T1B K52	N/A
Q303	FET	NEC	2SK508-T1B K52	N/A
Q308	NPN	Toshiba	2SC5086-Y TE85L	N/A
Q314	Transistor	Toshiba	2SA1586-GR TE85L	N/A
Q315	NPN	Toshiba	2SC4116-GR TE85L	N/A
Q317	Digital transistor	Rohm	UMC4N TR	N/A
Q318	NPN	Toshiba	2SC4116-GR TE85L	N/A
Q320	Transistor	Rohm	UMZ2N-TR	4809939C06
Q331	NPN	Toshiba	2SC4116-GR TE85L	N/A
Q404	NPN	Toshiba	2SC5086-Y TE85L	N/A
Q408	Transistor	Toshiba	2SC4215-Y TE85L	N/A
Q411	FET	Toshiba	2SK3476	DSTR013027
Q412	FET	Toshiba	2SK3475	DSTR013026
Q413	NPN	NEC	2SC3356-T1B R24	N/A
Q414	NPN	Toshiba	2SC5086-Y TE85L	N/A
Q416	NPN	Toshiba	2SC5086-Y TE85L	N/A
Q417	Digital transistor	Rohm	DTC114EETL	N/A
Q418	Digital transistor	Rohm	DTC144EETL	4880048M03
Q501	Digital transistor	Rohm	UMC4N TR	N/A
Q503	FET	Toshiba	2SJ144Y-TE85L	N/A
Q504	Digital transistor	Rohm	DTC144EETL	4880048M03
Q509	PNP	Rohm	DTA144EETL	N/A
Q601	Digital transistor	Rohm	DTC144EETL	4880048M03
Q605	Digital transistor	Rohm	DTC144EETL	4880048M03
Q608	Digital transistor	Rohm	DTC144EETL	4880048M03
Q609	Digital transistor	Rohm	UMG2N TR	N/A

Circuit Ref	Description	Vendor	Vendor Part Number	Motorola Equivalent Part Number
Q613	PNP	Rohm	DTA144EETL	N/A
Q616	FET	Toshiba	SSM3K03FE-TE85L	N/A
Q701	Digital transistor	Rohm	DTC144EETL	4880048M03
Q703	Digital transistor	Rohm	DTC144EETL	4880048M03
Q704	Transistor	Toshiba	2SA1586-GR TE85L	N/A
Q707	PNP	Toshiba	2SA1313-Y TE85L	N/A
Q708	Transistor	Toshiba	2SA1586-GR TE85L	N/A
Q709	Transistor	Toshiba	2SA1586-GR TE85L	N/A
Q916	FET	NEC	2SJ243-T1	N/A
	<b>DIODE:</b>			
Q203	Single	Rohm	1SR154-400 TE25	4842006M02
Q311	Var. Cap. Diode	Toshiba	1SV228-TPH3	N/A
Q316	Zener ;7.6V	Rohm	UDZ S 7.5B TE-17	N/A
Q319	Single	Rohm	1SS355 TE-17	4870360C15
Q322	Var. Cap. Diode	Toshiba	1SV217-TPH3	N/A
Q401	Var. Cap. Diode	Toshiba	1SV279-TPH3	N/A
Q402	Var. Cap. Diode	Toshiba	1SV279-TPH3	N/A
Q403	Dual Varactor	Toshiba	1SS362-TE85L	N/A
Q405	Var. Cap. Diode	Toshiba	1SV279-TPH3	N/A
Q406	Var. Cap. Diode	Toshiba	1SV279-TPH3	N/A
Q407	Diode	HP	HSMS-2817	N/A
Q409	Single	Hitachi	HVU131TRF	N/A
Q410	Diode	MA/COM	MA4PH262	N/A
Q415	Single	Hitachi	HSC277TRF	N/A
Q420	NU			
Q507	Dual	Rohm	DAN235ETL	N/A
Q508	Dual	Rohm	DAN235ETL	N/A
Q511	Diode	Rohm	RB521S-30 TE61	N/A
Q607	NU			
Q614	Diode	Toshiba	1SS372-TE85L	N/A
Q615	Dual	Rohm	DAN222TL	4809606E02
Q705	Single	Rohm	1SR154-400 TE25	4842006M02
Q706	Zener;6.9V	Rohm	UDZ S 6.8B TE-17	4842006M03
Q710	Zener;20.39V	Rohm	UDZ S 20B TE-17	N/A
Q711	Single	Rohm	1SR154-400 TE25	4842006M02
Q712	Single	Rohm	1SS355 TE-17	4870360C15
Q921	Var. Cap. Diode	Toshiba	JDV2S01E-TPH3	N/A
Q922	Var. Cap. Diode	Toshiba	1SV270-TPH3	N/A
	<b>INTEGRATED CIRCUIT:</b>			
Q204	IC	Torex	XC62HR5002PR	DSIC510004
Q301	IC	TOKO	TK11816M	DSIC011011
Q323	IC	Fujitsu	MB15A02PFV1-ER	DSIC042003
Q419	IC, Op-Amp	JRC	NJM2904V(Te1)	DSIC510001
Q502	IC, Op-Amp	JRC	NJM324V(Te1)	DSIC510002
Q505	IC, Op-Amp	JRC	NJM324V(Te1)	DSIC510002
Q506	IC	Toshiba	TA31136FN-TP1	DSIC013007
Q510	IC, Op-Amp	JRC	NJM2107F (TE1)	DSIC025016
Q602	IC, Op-Amp	JRC	NJM324V(Te1)	DSIC510002
Q610	IC, Op-Amp	JRC	NJM324V(Te1)	DSIC510002
Q617	IC, Op-Amp	JRC	NJM2107F (TE1)	DSIC025016
Q702	IC	Philips	TDA8541T/N1	DSIC174004

Circuit Ref	Description	Vendor	Vendor Part Number	Motorola Equivalent Part Number
	<b>COIL:</b>			
L301	22nH	TOKO	LL1608-FS22NJ	N/A
L302	390nH	Sagami Elec	C2012C-R39J	2462587V41
L303	27nH	Sagami Elec	C2012C-27NG	N/A
L304	390nH	Sagami Elec	C2012C-R39J	2462587V41
L305	390nH	Sagami Elec	C2012C-R39J	2462587V41
L306	390nH	Sagami Elec	C2012C-R39J	2462587V41
L307	390nH	Sagami Elec	C2012C-R39J	2462587V41
L308	390nH	Sagami Elec	C2012C-R39J	2462587V41
L309	22nH	Sagami Elec	C2012C-22NG	N/A
L310	390nH	Sagami Elec	C2012C-R39J	2462587V41
L312	Chip emifil	Murata	BLM21A121SPT	2480067M02
L313	1000uH	TDK	NL453232T-102J	N/A
L401	Airwound Coil	Uchida/Latest	E2-0.30-1.0-5TL	N/A
L402	Airwound Coil	Uchida/Latest	E2-0.30-1.0-5TL	N/A
L403	NU			
L404	180nH	Sagami Elec	C2012C-R15J	2462587V36
L405	Airwound Coil	Uchida/Latest	E2-0.30-1.0-7TL	N/A
L406	Airwound Coil	Uchida/Latest	E2-0.30-1.0-5TL	N/A
L407	Airwound Coil	Uchida/Latest	E2-0.30-1.0-5TL	N/A
L408	Coil	Latest	SMD-0314A	N/A
L409	Coil	Latest	SMD-0314A	N/A
L410	15nH	TOKO	LL2012-FH15NJ	N/A
L411	15nH	TOKO	LL2012-FH15NJ	N/A
L412	50nH	Sagami Elec	C2012C-R15J	N/A
L413	470nH	Toko	FSLM2520-R47K	2485602J33
L414	Airwound Coil	Uchida/Latest	E2-0.40-1.0-5TL	N/A
L415	Airwound Coil	Uchida/Latest	E2-0.40-1.0-5TL	N/A
L416	Airwound Coil	Uchida/Latest	E2-0.40-1.0-5TL	N/A
L417	390nH	Sagami Elec	C2012C-R39J	2462587V41
L418	Airwound Coil	Uchida/Latest	E2-0.40-0.8-2TL	N/A
L419	Airwound Coil	Uchida/Latest	E2-0.40-1.0-5TL	N/A
L420	Airwound Coil	Uchida/Latest	E2-0.30-1.0-7TL	N/A
L421	Airwound Coil	Uchida/Latest	E2-0.40-0.9-3TL	N/A
L422	Airwound Coil	Uchida/Latest	E2-0.30-1.0-7TL	N/A
L423	Airwound Coil	Uchida/Latest	E2-0.40-0.9-3TL	N/A
L424	18nH	TOKO	LL1608-FS18NJ	N/A
L425	18nH	TOKO	LL1608-FS18NJ	N/A
L426	22nH	TOKO	LL1608-FS22NJ	N/A
L427	Chip Beads	TDK	ZBFS5105-PT	N/A
L428	NU			
L430	Airwound Coil	Uchida/Latest	E2-0.30-1.0-4TL	4880048M03
L431	1uH	TDK	MLF1608A1R0KT	N/A
L432	1uH	TDK	MLF1608A1R0KT	N/A
L501	1uH	TDK	MLF1608A1R0KT	N/A
L702	390nH	Sagami Elec	C2012C-R39J	2462587V41
	<b>JACK:</b>			
CN201	Connector contact Battery	Motorola	09D86237A	0986237A01
CN701	Connector	Matsushita	AXK6S40545J/P	DSCN097003
J401	Antenna Jack	Motorola	02D80689C	0280689C01
J701	Audio Jack	Motorola	09R80683Z	0980683Z01

Circuit Ref	Description	Vendor	Vendor Part Number	Motorola Equivalent Part Number
	<b>CERAMIC FILTER:</b>			
F401	NU			
F501	Ceramic filter	Toko	BLFYM455D	N/A
F502	455Khz	TOKO	ALFYM455G	N/A
	<b>CRYSTAL</b>			
F402	Filter , 45.1 MHz	HERTZ	45N12A5 (45.1MHz) UM-5J-SMD	DSXF137006
X301	Crystal	Nikko Denshi	TOP-B 14.4MHz RANK-2	DSXT181002
X501	Crystal	Nikko Denshi	TOP-B 44.645MHz +- 10ppm, +-4ppm	DSXT181006
	<b>MISCELLANEOUS</b>			
CD501	Discriminator	Samsung	IFD0455C24E03	N/A
J702	Connector	Molex	53047-0210	N/A
P701	SP WIRE Assembly	EU-connector	WC-013	N/A
PB201	PCB	SHIKIBO	K001C803-8	N/A
SW201	Potentiometers	Tocos	TP76N17N A10Kohm 10SK	DSVR010008
SP701	Speaker	Orient sound	K028NA	N/A
	<b>RESISTOR:</b>			
R201	10 Kohm; 0.1W; +-5%	Rohm	MCR03 EZHJ 103	0662057A73
R202	2.2 Kohm; 0.1W; +-5%	Rohm	MCR03 EZHJ 222	0662057A57
R203	4.7 Kohm; 0.1W; +-5%	Rohm	MCR03 EZHJ 472	0662057A65
R204	4.7 Kohm; 0.1W; +-5%	Rohm	MCR03 EZHJ 472	0662057A65
R205	50K ohm	Hokuriku	NSM3503J400J	N/A
R206	NU			
R207	10 Kohm; 0.1W; +-5%	Rohm	MCR03 EZHJ 103	0662057A73
R208	4.7 Kohm; 0.1W; +-5%	Rohm	MCR03 EZHJ 472	0662057A65
R209	10 ohm; 0.1W; +-5%	Rohm	MCR03 EZHJ 100	0662057A01
R210	22 ohm; 0.1W; +-5%	Rohm	MCR03 EZHJ 220	0662057A09
R211	10 Kohm; 0.1W; +-5%	Rohm	MCR03 EZHJ 103	0662057A73
R212	100 ohm; 0.1W; +-5%	Rohm	MCR03 EZHJ 101	0662057A25
R301	1 Kohm; 0.1W; +-5%	Rohm	MCR03 EZHJ 102	0662057A49
R302	220 ohm; 0.1W; +-5%	Rohm	MCR03 EZHJ 221	0662057A33
R310	100 ohm; 0.1W; +-5%	Rohm	MCR03 EZHJ 101	0662057A25
R311	15 Kohm; 0.1W; +-5%	Rohm	MCR03 EZHJ 153	0662057A77
R312	220 ohm; 0.1W; +-5%	Rohm	MCR03 EZHJ 221	0662057A33
R313	100 Kohm; 0.1W; +-5%	Rohm	MCR03 EZHJ 104	0662057A97
R314	0 ohm; 0.1W; +-5%	Rohm	MCR03 EZHJ 000	0662057B47
R315	2.7 Kohm; 0.1W; +-5%	Rohm	MCR03 EZHJ 272	0662057A59
R316	1.5 Kohm; 0.1W; +-5%	Rohm	MCR03 EZHJ 152	0662057A53
R317	3.3 Kohm; 0.1W; +-5%	Rohm	MCR03 EZHJ 332	0662057A61
R318	10 Kohm; 0.1W; +-5%	Rohm	MCR03 EZHJ 103	0662057A73
R319	10 Kohm; 0.1W; +-5%	Rohm	MCR03 EZHJ 103	0662057A73
R320	6.8 Kohm; 0.1W; +-5%	Rohm	MCR03 EZHJ 682	0662057A69
R321	6.8 Kohm; 0.1W; +-5%	Rohm	MCR03 EZHJ 682	0662057A69
R323	Chip network resistor	Hokuriku	CRA168-472J	DSRA508001
R325	10 Kohm; 0.1W; +-5%	Rohm	MCR03 EZHJ 103	0662057A73
R327	100 Kohm; 0.1W; +-5%	Rohm	MCR03 EZHJ 104	0662057A97
R329	220 Kohm; 0.1W; +-1%	Rohm	MCR03 EZHF 2203	N/A

Circuit Ref	Description	Vendor	Vendor Part Number	Motorola Equivalent Part Number
R330	10K ohm	Murata	NTH5G16P39A103K07 TH	N/A
R332	100 Kohm; 0.1W; +-1%	Rohm	MCR03 EZHF 1003	0662057P95
R333	100 Kohm; 0.1W; +-5%	Rohm	MCR03 EZHJ 104	0662057A97
R335	100 Kohm; 0.1W; +-5%	Rohm	MCR03 EZHJ 104	0662057A97
R336	100 Kohm; 0.1W; +-5%	Rohm	MCR03 EZHJ 104	0662057A97
R337	150 Kohm; 0.1W; +-1%	Rohm	MCR03 EZHF 1503	0662057P97
R355	NU			
R356	4.7 Kohm; 0.1W; +-5%	Rohm	MCR03 EZHJ 472	0662057A65
R357	10 ohm; 0.1W; +-5%	Rohm	MCR03 EZHJ 100	0662057A01
R358	47 ohm; 0.1W; +-5%	Rohm	MCR03 EZHJ 470	0662057A17
R359	4.7 Kohm; 0.1W; +-5%	Rohm	MCR03 EZHJ 472	0662057A65
R361	22 Kohm; 0.1W; +-5%	Rohm	MCR03 EZHJ 223	0662057A81
R362	22 Kohm; 0.1W; +-5%	Rohm	MCR03 EZHJ 223	0662057A81
R364	6.8 Kohm; 0.1W; +-5%	Rohm	MCR03 EZHJ 682	0662057A69
R366	470 ohm; 0.1W; +-5%	Rohm	MCR03 EZHJ 471	0662057A41
R367	470 ohm; 0.1W; +-5%	Rohm	MCR03 EZHJ 471	0662057A41
R401	100 Kohm; 0.1W; +-5%	Rohm	MCR03 EZHJ 104	0662057A97
R402	100 Kohm; 0.1W; +-5%	Rohm	MCR03 EZHJ 104	0662057A97
R403	12 Kohm; 0.1W; +-5%	Rohm	MCR03 EZHJ 123	0662057A51
R404	4.7 Kohm; 0.1W; +-5%	Rohm	MCR03 EZHJ 472	0662057A65
R405	6.8 Kohm; 0.1W; +-5%	Rohm	MCR03 EZHJ 682	0662057A69
R406	0 ohm; 0.1W; +-5%	Rohm	MCR03 EZHJ 000	0662057B47
R407	470 ohm; 0.1W; +-5%	Rohm	MCR03 EZHJ 471	0662057A41
R408	100 Kohm; 0.1W; +-5%	Rohm	MCR03 EZHJ 104	0662057A97
R409	100 Kohm; 0.1W; +-5%	Rohm	MCR03 EZHJ 104	0662057A97
R410	100 Kohm; 0.1W; +-5%	Rohm	MCR03 EZHJ 104	0662057A97
R412	56 ohm; 0.1W; +-5%	Rohm	MCR03 EZHJ 560	0662057A19
R413	0 ohm; 0.1W; +-5%	Rohm	MCR03 EZHJ 000	0662057B47
R415	150 Kohm; 0.1W; +-5%	Rohm	MCR03 EZHJ 154	0662057B02
R416	NU			
R417	220 ohm; 0.1W; +-5%	Rohm	MCR03 EZHJ 221	0662057A33
R418	470 ohm; 0.1W; +-5%	Rohm	MCR03 EZHJ 471	0662057A41
R419	56 ohm; 0.1W; +-5%	Rohm	MCR03 EZHJ 560	0662057A19
R420	33 Kohm; 0.1W; +-5%	Rohm	MCR03 EZHJ 333	0662057A85
R421	22 Kohm; 0.1W; +-5%	Rohm	MCR03 EZHJ 223	0662057A81
R422	470 ohm; 0.1W; +-5%	Rohm	MCR03 EZHJ 471	0662057A41
R423	100 ohm; 0.1W; +-5%	Rohm	MCR03 EZHJ 101	0662057A25
R424	33 Kohm; 0.1W; +-5%	Rohm	MCR03 EZHJ 333	0662057A85
R425	100 Kohm; 0.1W; +-5%	Rohm	MCR03 EZHJ 104	0662057A97
R426	NU			
R427	22 ohm; 0.1W; +-5%	Rohm	MCR03 EZHJ 220	0662057A09
R428	820 Kohm; 0.1W; +-5%	Rohm	MCR03 EZHJ 824	0662057B20
R429	4.7 Kohm; 0.1W; +-5%	Rohm	MCR03 EZHJ 472	0662057A65
R430	100 ohm; 0.1W; +-5%	Rohm	MCR03 EZHJ 101	0662057A25
R431	10 Kohm; 0.1W; +-5%	Rohm	MCR03 EZHJ 103	0662057A73
R432	220 ohm; 0.1W; +-5%	Rohm	MCR03 EZHJ 221	0662057A33
R433	10 Kohm; 0.1W; +-5%	Rohm	MCR03 EZHJ 103	0662057A73
R434	100 ohm; 0.1W; +-5%	Rohm	MCR03 EZHJ 101	0662057A25
R435	2.2 ohm; 0.1W; +-5%	Rohm	MCR03 EZHJ 2R2	0662057W09
R436	10 Kohm; 0.1W; +-5%	Rohm	MCR03 EZHJ 103	0662057A73

Circuit Ref	Description	Vendor	Vendor Part Number	Motorola Equivalent Part Number
R437	4.7 Kohm; 0.1W; +-5%	Rohm	MCR03 EZHJ 472	0662057A65
R438	1 Kohm; 0.1W; +-5%	Rohm	MCR03 EZHJ 102	0662057A49
R439	330 ohm; 0.1W; +-5%	Rohm	MCR03 EZHJ 331	0662057A37
R440	22 ohm; 0.1W; +-5%	Rohm	MCR03 EZHJ 220	0662057A09
R441	330 ohm; 0.1W; +-5%	Rohm	MCR03 EZHJ 331	0662057A37
R442	0.1ohm 1W	Hokuriku	LPR1R100FE	N/A
R443	100 Kohm; 0.1W; +-1%	Rohm	MCR03 EZHF 1003	0662057P95
R444	100 Kohm; 0.1W; +-1%	Rohm	MCR03 EZHF 1003	0662057P95
R445	100 Kohm; 0.1W; +-1%	Rohm	MCR03 EZHF 1003	0662057P95
R446	100 Kohm; 0.1W; +-1%	Rohm	MCR03 EZHF 1003	0662057P95
R447	97.6 Kohm; 0.1W; +-1%	Rohm	MCR03 EZHF 9762	N/A
R448	100 Kohm; 0.1W; +-5%	Rohm	MCR03 EZHJ 104	0662057A97
R449	100 Kohm; 0.1W; +-1%	Rohm	MCR03 EZHF 1003	0662057P95
R450	10 Kohm; 0.1W; +-5%	Rohm	MCR03 EZHJ 103	0662057A73
R451	100 Kohm; 0.1W; +-5%	Rohm	MCR03 EZHJ 104	0662057A97
R452	33 Kohm;0.1W;+-5%	Rohm	MCR03 EZHJ 333	0662057A85
R453	1 Mohm; 0.1W; +-5%	Rohm	MCR03 EZHJ 105	0662057B22
R454	15 Kohm; 0.1W; +-5%	Rohm	MCR03 EZHJ 153	0662057A77
R455	100 Kohm; 0.1W; +-5%	Rohm	MCR03 EZHJ 104	0662057A97
R459	3.3 Kohm; 0.1W; +-5%	Rohm	MCR03 EZHJ 332	0662057A61
R466	1 Kohm; 0.1W; +-5%	Rohm	MCR03 EZHJ 102	0662057A49
R468	1 Kohm; 0.1W; +-5%	Rohm	MCR03 EZHJ 102	0662057A49
R469	2.2 Kohm; 0.1W; +-5%	Rohm	MCR03 EZHJ 222	0662057A57
R501	0 ohm; 0.1W; +-5%	Rohm	MCR03 EZHJ 000	0662057B47
R502	47 Kohm; 0.1W; +-5%	Rohm	MCR03 EZHJ 473	0662057A89
R503	2.7 Kohm; 0.1W; +-5%	Rohm	MCR03 EZHJ 272	0662057A59
R505	2.2 Kohm; 0.1W; +-5%	Rohm	MCR03 EZHJ 222	0662057A57
R506	3.3 Kohm; 0.1W; +-5%	Rohm	MCR03 EZHJ 332	0662057A61
R507	1 Kohm; 0.1W; +-5%	Rohm	MCR03 EZHJ 102	0662057A49
R508	10 Kohm; 0.1W; +-5%	Rohm	MCR03 EZHJ 103	0662057A73
R509	68 Kohm; 0.1W; +-5%	Rohm	MCR03 EZHJ 683	0662057A93
R510	470 Kohm; 0.1W; +-5%	Rohm	MCR03 EZHJ 474	0662057B14
R511	56 Kohm; 0.1W; +-5%	Rohm	MCR03 EZHJ 563	0662057A91
R512	47 Kohm; 0.1W; +-5%	Rohm	MCR03 EZHJ 473	0662057A89
R513	10 Kohm; 0.1W; +-5%	Rohm	MCR03 EZHJ 103	0662057A73
R514	1 Kohm; 0.1W; +-5%	Rohm	MCR03 EZHJ 102	0662057A49
R515	25.5 Kohm; 0.1W; +-1%	Rohm	MCR03 EZHF 2552	0662057T92
R516	29.4 Kohm; 0.1W; +-1%	Rohm	MCR03 EZHF 2942	0662057P29
R517	15.8 Kohm; 0.1W; +-1%	Rohm	MCR03 EZHF 1582	0662057Z03
R518	11.5 Kohm; 0.1W; +-1%	Rohm	MCR03 EZHF 1152	0662057Z35
R519	150 Kohm; 0.1W; +-1%	Rohm	MCR03 EZHF 1503	0662057P97
R520	4.22 Kohm; 0.1W; +-1%	Rohm	MCR03 EZHF 4221	N/A
R521	715 Kohm; 0.1W; +-1%	Rohm	MCR03 EZHF 7153	0662057T99
R522	NU			
R523	47 Kohm; 0.1W; +-5%	Rohm	MCR03 EZHJ 473	0662057A89
R524	2.2 Kohm; 0.1W; +-5%	Rohm	MCR03 EZHJ 222	0662057A57
R525	10 Kohm; 0.1W; +-5%	Rohm	MCR03 EZHJ 103	0662057A73
R526	0 ohm; 0.1W; +-5%	Rohm	MCR03 EZHJ 000	0662057B47
R527	10 Kohm; 0.1W; +-5%	Rohm	MCR03 EZHJ 103	0662057A73
R530	22 Kohm; 0.1W; +-5%	Rohm	MCR03 EZHJ 223	0662057A81
R531	22 Kohm; 0.1W; +-5%	Rohm	MCR03 EZHJ 223	0662057A81

Circuit Ref	Description	Vendor	Vendor Part Number	Motorola Equivalent Part Number
R532	1.5 Mohm;0.1W;+-5%	Rohm	MCR03 EZHJ 155	N/A
R534	330 Kohm; 0.1W; +-5%	Rohm	MCR03 EZHJ 334	0662057B10
R535	2.2 Kohm; 0.1W; +-5%	Rohm	MCR03 EZHJ 222	0662057A57
R536	1 Kohm; 0.1W; +-5%	Rohm	MCR03 EZHJ 102	0662057A49
R537	470 Kohm; 0.1W; +-5%	Rohm	MCR03 EZHJ 474	0662057B14
R538	100 Kohm; 0.1W; +-5%	Rohm	MCR03 EZHJ 104	0662057A97
R539	100 Kohm; 0.1W; +-5%	Rohm	MCR03 EZHJ 104	0662057A97
R540	22 Kohm; 0.1W; +-5%	Rohm	MCR03 EZHJ 223	0662057A81
R541	22 Kohm; 0.1W; +-5%	Rohm	MCR03 EZHJ 223	0662057A81
R542	22 Kohm; 0.1W; +-5%	Rohm	MCR03 EZHJ 223	0662057A81
R543	100 Kohm; 0.1W; +-5%	Rohm	MCR03 EZHJ 104	0662057A97
R544	100 Kohm; 0.1W; +-5%	Rohm	MCR03 EZHJ 104	0662057A97
R545	100 Kohm; 0.1W; +-5%	Rohm	MCR03 EZHJ 104	0662057A97
R546	100 Kohm; 0.1W; +-5%	Rohm	MCR03 EZHJ 104	0662057A97
R547	100 Kohm; 0.1W; +-5%	Rohm	MCR03 EZHJ 104	0662057A97
R548	10 Kohm; 0.1W; +-5%	Rohm	MCR03 EZHJ 103	0662057A73
R549	100 Kohm; 0.1W; +-5%	Rohm	MCR03 EZHJ 104	0662057A97
R550	1 Kohm; 0.1W; +-5%	Rohm	MCR03 EZHJ 102	0662057A49
R551	0 ohm; 0.1W; +-5%	Rohm	MCR03 EZHJ 000	0662057B47
R560	5.6 Kohm; 0.1W; +-1%	Rohm	MCR03 EZHF 562	N/A
R561	634 Kohm; 0.1W; +-5%	Rohm	MCR03 EZHF 6343	N/A
R563	0 ohm; 0.1W; +-5%	Rohm	MCR03 EZHJ 000	0662057B47
R564	82 Kohm; 0.1W; +-1%	Rohm	MCR03 EZHF 8202	N/A
R565	18 Kohm; 0.1W; +-5%	Rohm	MCR03 EZHJ 183	0662057A79
R566	6.8 Kohm; 0.1W; +-5%	Rohm	MCR03 EZHJ 682	0662057A69
R567	10K ohm	Murata	NTH5G16P39A103K07 TH	N/A
R568	4.7 Kohm; 0.1W; +-5%	Rohm	MCR03 EZHJ 472	0662057A65
R569	1 Kohm; 0.25W; +-5%	Hokuriku	CR1/4-102J	N/A
R570	120 Kohm; 0.1W; +-5%	Rohm	MCR03 EZHJ 124	N/A
R571	220 Kohm	MURATA	NCP18WM224K03RB	N/A
R601	1 Mohm; 0.1W; +-5%	Rohm	MCR03 EZHJ 105	0662057B22
R602	6.8 Kohm; 0.1W; +-5%	Rohm	MCR03 EZHJ 682	0662057A69
R604	6.8 Kohm; 0.1W; +-5%	Rohm	MCR03 EZHJ 682	0662057A69
R605	100 Kohm; 0.1W; +-5%	Rohm	MCR03 EZHJ 104	0662057A97
R606	100 Kohm; 0.1W; +-5%	Rohm	MCR03 EZHJ 104	0662057A97
R607	100 Kohm; 0.1W; +-5%	Rohm	MCR03 EZHJ 104	0662057A97
R608	100 Kohm; 0.1W; +-5%	Rohm	MCR03 EZHJ 104	0662057A97
R609	680 Kohm; 0.1W; +-5%	Rohm	MCR03 EZHJ 684	0662057B18
R610	10 Kohm; 0.1W; +-5%	Rohm	MCR03 EZHJ 103	0662057A73
R611	50K ohm	Hokuriku	NSM3503J400J	N/A
R612	47 Kohm; 0.1W; +-5%	Rohm	MCR03 EZHJ 473	0662057A89
R615	12 Kohm; 0.1W; +-5%	Rohm	MCR03 EZHJ 123	0662057A51
R616	4.7 Kohm; 0.1W; +-5%	Rohm	MCR03 EZHJ 472	0662057A65
R617	100 Kohm; 0.1W; +-5%	Rohm	MCR03 EZHJ 104	0662057A97
R620	4.7 Kohm; 0.1W; +-5%	Rohm	MCR03 EZHJ 472	0662057A65
R621	330 Kohm; 0.1W; +-5%	Rohm	MCR03 EZHJ 334	0662057B10
R622	0 ohm; 0.1W; +-5%	Rohm	MCR03 EZHJ 000	0662057B47
R625	18 Kohm; 0.1W; +-5%	Rohm	MCR03 EZHJ 183	0662057A79
R626	18 Kohm; 0.1W; +-5%	Rohm	MCR03 EZHJ 183	0662057A79
R627	680 Kohm; 0.1W; +-5%	Rohm	MCR03 EZHJ 684	0662057B18

Circuit Ref	Description	Vendor	Vendor Part Number	Motorola Equivalent Part Number
R628	0 ohm; 0.1W; +-5%	Rohm	MCR03 EZHJ 000	0662057B47
R629	NU			
R631	NU			
R633	18 Kohm; 0.1W; +-5%	Rohm	MCR03 EZHJ 183	0662057A79
R634	470 Kohm; 0.1W; +-5%	Rohm	MCR03 EZHJ 474	0662057B14
R635	1 Mohm; 0.1W; +-5%	Rohm	MCR03 EZHJ 105	0662057B22
R636	0 ohm; 0.1W; +-5%	Rohm	MCR03 EZHJ 000	0662057B47
R637	0 ohm; 0.1W; +-5%	Rohm	MCR03 EZHJ 000	0662057B47
R638	270 Kohm; 0.1W; +-5%	Rohm	MCR03 EZHJ 274	NA
R639	270 Kohm; 0.1W; +-5%	Rohm	MCR03 EZHJ 274	NA
R640	220 Kohm; 0.1W; +-5%	Rohm	MCR03 EZHJ 224	N/A
R641	47 Kohm; 0.1W; +-5%	Rohm	MCR03 EZHJ 473	0662057A89
R642	33 Kohm; 0.1W; +-1%	Rohm	MCR03 EZHF 3302	N/A
R643	22 Kohm; 0.1W; +-1%	Rohm	MCR03 EZHF 2202	N/A
R645	1 Mohm; 0.1W; +-5%	Rohm	MCR03 EZHJ 105	0662057B22
R646	1 Kohm; 0.1W; +-5%	Rohm	MCR03 EZHJ 102	0662057A49
R648	470 Kohm; 0.1W; +-5%	Rohm	MCR03 EZHJ 474	0662057B14
R649	100 Kohm; 0.1W; +-5%	Rohm	MCR03 EZHJ 104	0662057A97
R650	100 Kohm; 0.1W; +-5%	Rohm	MCR03 EZHJ 104	0662057A97
R651	100 Kohm; 0.1W; +-5%	Rohm	MCR03 EZHJ 104	0662057A97
R652	680 Kohm; 0.1W; +-5%	Rohm	MCR03 EZHJ 684	0662057B18
R655	4.7 Kohm; 0.1W; +-5%	Rohm	MCR03 EZHJ 472	0662057A65
R656	100 ohm; 0.1W; +-5%	Rohm	MCR03 EZHJ 101	0662057A25
R657	0 ohm; 0.1W; +-5%	Rohm	MCR03 EZHJ 000	0662057B47
R658	820 ohm; 0.1W; +-5%	Rohm	MCR03 EZHJ 821	0662057A47
R659	12 Kohm; 0.1W; +-5%	Rohm	MCR03 EZHJ 123	0662057A51
R660	NU			
R661	10 Kohm; 0.1W; +-5%	Rohm	MCR03 EZHJ 103	0662057A73
R663	100 Kohm; 0.1W; +-5%	Rohm	MCR03 EZHJ 104	0662057A97
R664	6.8 Kohm; 0.1W; +-5%	Rohm	MCR03 EZHJ 682	0662057A69
R665	1 Mohm; 0.1W; +-5%	Rohm	MCR03 EZHJ 105	0662057B22
R666	68 Kohm; 0.1W; +-5%	Rohm	MCR03 EZHJ 683	0662057A93
R667	330 Kohm; 0.1W; +-5%	Rohm	MCR03 EZHJ 334	0662057B10
R668	1 Kohm; 0.1W; +-5%	Rohm	MCR03 EZHJ 102	0662057A49
R669	0 ohm; 0.1W; +-5%	Rohm	MCR03 EZHJ 000	0662057B47
R701	2.2 Kohm; 0.1W; +-5%	Rohm	MCR03 EZHJ 222	0662057A57
R702	1.5 Kohm; 0.1W; +-5%	Rohm	MCR03 EZHJ 152	0662057A53
R703	330 Kohm; 0.1W; +-5%	Rohm	MCR03 EZHJ 334	0662057B10
R704	47 Kohm; 0.1W; +-5%	Rohm	MCR03 EZHJ 473	0662057A89
R705	22 ohm; 0.1W; +-5%	Rohm	MCR03 EZHJ 220	0662057A09
R706	470 ohm; 0.1W; +-5%	Rohm	MCR03 EZHJ 471	0662057A41
R707	10 Kohm; 0.1W; +-5%	Rohm	MCR03 EZHJ 103	0662057A73
R708	2.2 Kohm; 0.1W; +-5%	Rohm	MCR03 EZHJ 222	0662057A57
R709	0.27 ohm; 0.125W; +-5%	Rohm	MCR10 EZHJ R27	0662057C02
R710	100 ohm; 0.1W; +-5%	Rohm	MCR03 EZHJ 101	0662057A25
R711	2.2 Kohm; 0.1W; +-5%	Rohm	MCR03 EZHJ 222	0662057A57
R712	1 Kohm; 0.1W; +-5%	Rohm	MCR03 EZHJ 102	0662057A49
R713	2.2 Kohm; 0.1W; +-5%	Rohm	MCR03 EZHJ 222	0662057A57
R714	2.2 Kohm; 0.1W; +-5%	Rohm	MCR03 EZHJ 222	0662057A57
R715	4.7 Kohm; 0.1W; +-5%	Rohm	MCR03 EZHJ 472	0662057A65
R716	0 ohm; 0.1W; +-5%	Rohm	MCR10 EZH J 000	0662057C01

Circuit Ref	Description	Vendor	Vendor Part Number	Motorola Equivalent Part Number
R717	0 ohm; 0.1W; +-5%	Rohm	MCR10 EZH J 000	0662057C01
R913	10 Kohm; 0.1W; +-5%	Rohm	MCR03 EZHJ 103	0662057A73
R914	150 Kohm; 0.1W; +-5%	Rohm	MCR03 EZHJ 151	N/A
R928	150 Kohm; 0.1W; +-5%	Rohm	MCR03 EZHJ 151	N/A
R929	10 Kohm; 0.1W; +-5%	Rohm	MCR03 EZHJ 103	0662057A73
R930	100 Kohm; 0.1W; +-5%	Rohm	MCR03 EZHJ 104	0662057A97
R934	1 Kohm; 0.1W; +-5%	Rohm	MCR03 EZHJ 102	0662057A49
R935	4.7 Kohm; 0.1W; +-5%	Rohm	MCR03 EZHJ 472	0662057A65
RV601	10 Kohm; 0.1W; +-5%	Rohm	MVR22 HXBR N 103	N/A
RV602	10 Kohm; 0.1W; +-5%	Rohm	MVR22 HXBR N 103	N/A

---

**Chapter 8 UHF 435-480 MHz Circuit Board/Schematic Diagrams and Parts List**

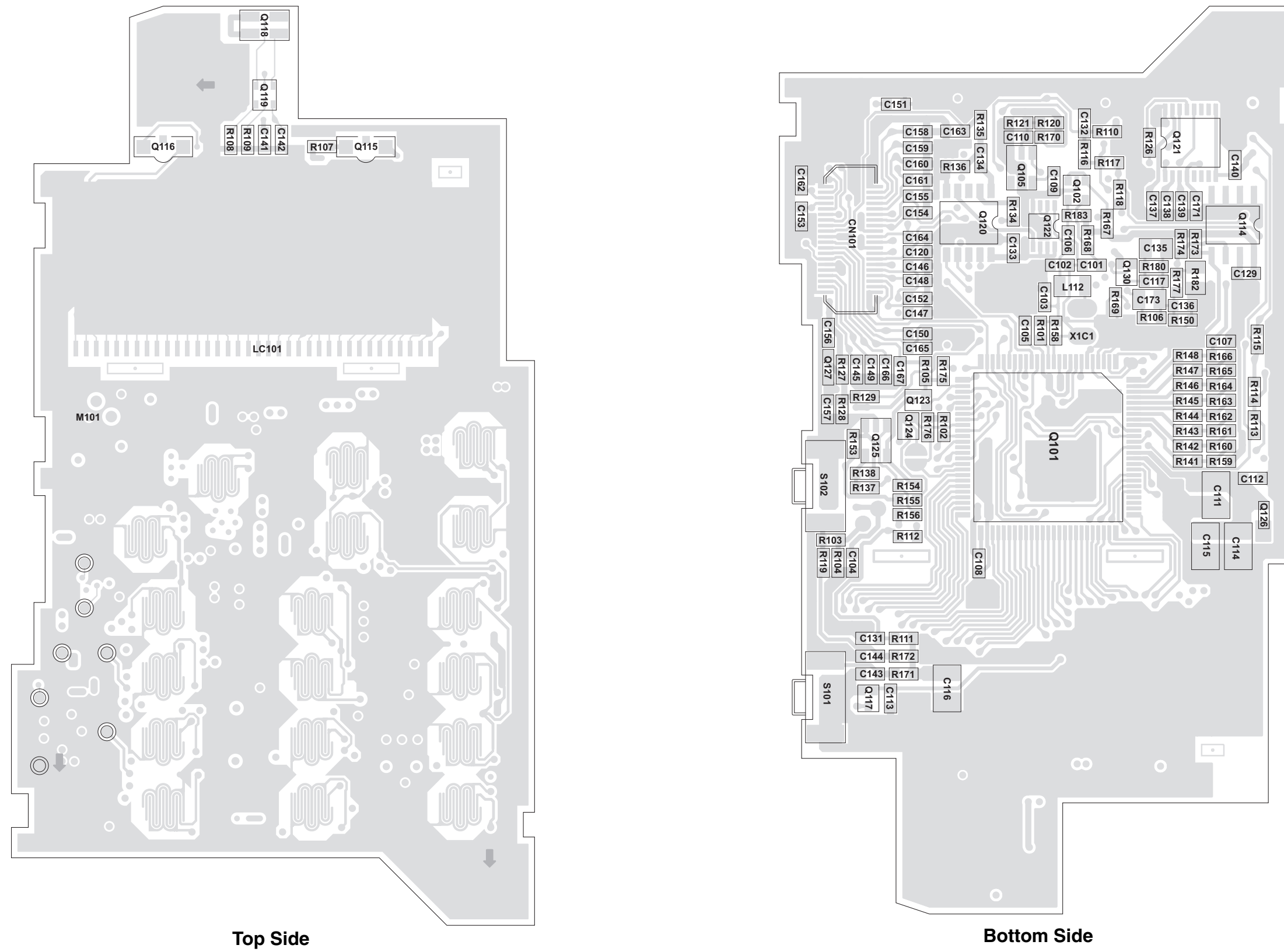

Figure 8-18. UHF 435-480 MHz Controller Board



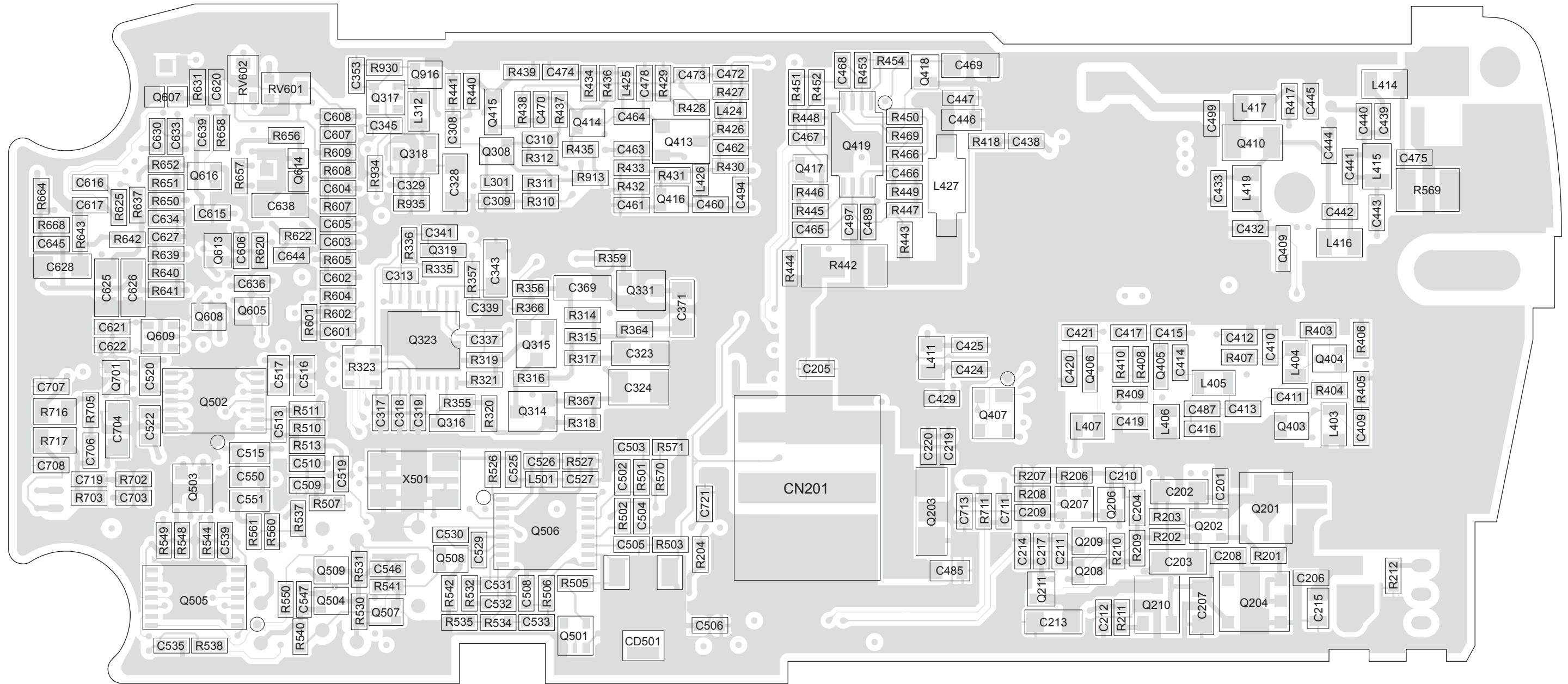

Figure 8-19. UHF 435-480 MHz Main Board Top Side

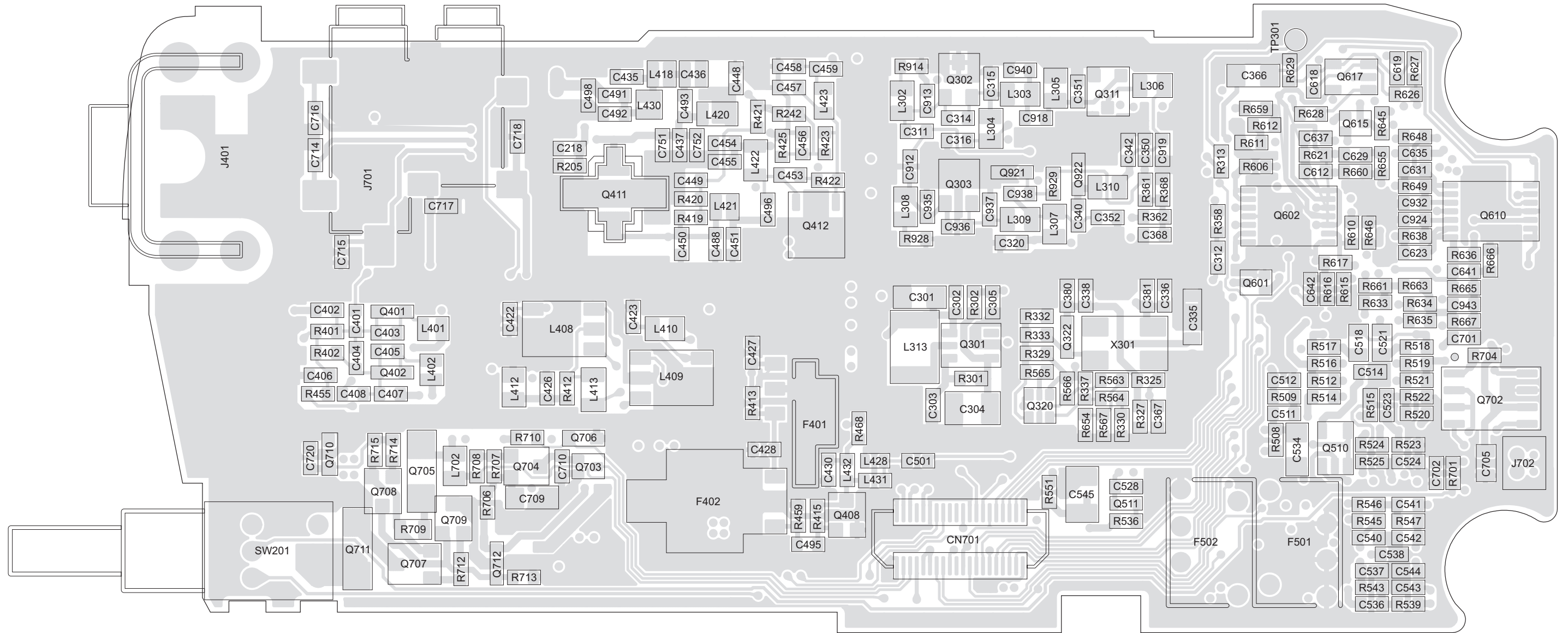

Figure 8-20. UHF 435-480 MHz Main Board Bottom Side

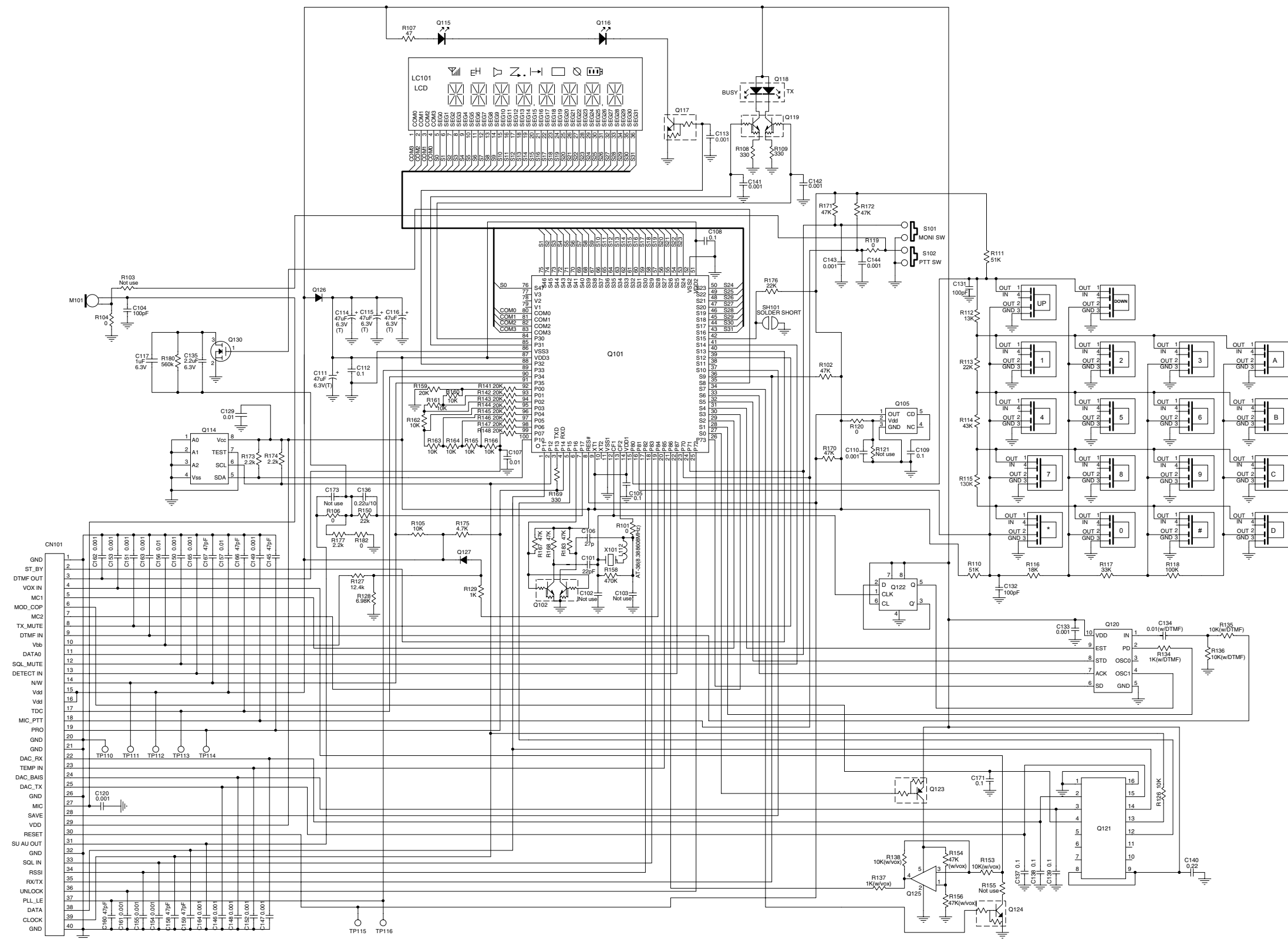

Figure 8-21. UHF 435-480 MHz Complete Controller Board Schematic Diagram

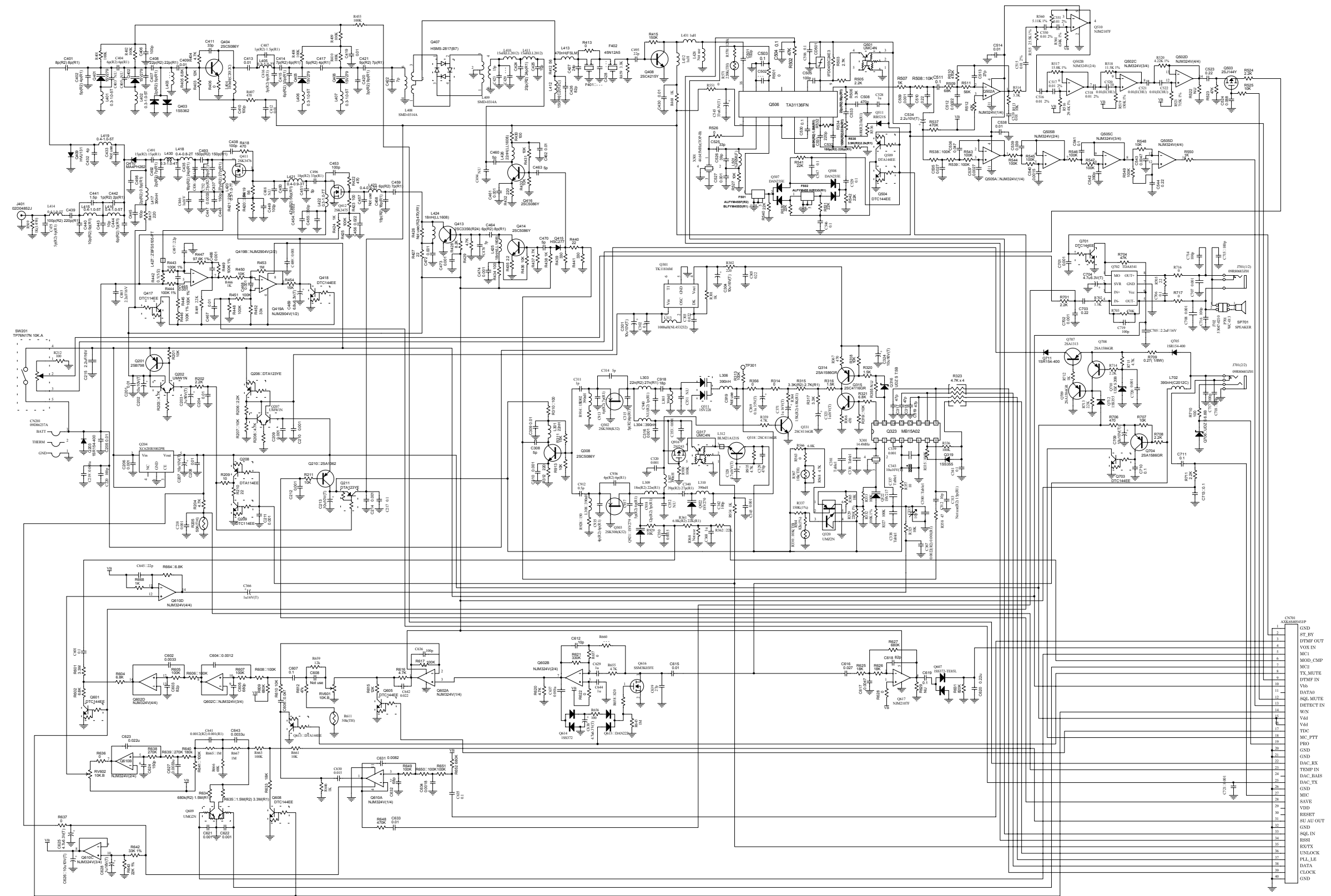

Figure 8-22. UHF 435-480 MHz Main Board

## UHF 435-480 MHz Radio Parts List (Controller Board)

Circuit Ref	Description	Vendor	Vendor Part Number	Motorola Equivalent Part Number
C101	22pF; 50V; +-5%	Murata	GRM39CH220J50PT	2113740F35
C102	NU			
C103	10pF; 50V; +-5%	Murata	GRM39CH100J50PT	N/A
C104	100pF; 50V; +-5%	Murata	GRM39CH101J50PT	2113740F51
C105	0.1uF; 16V; +-10%	Murata	GRM39B104K16PT	N/A
C106	27pF; 50V; +-5%	Murata	GRM39CH270J50PT	2113740F37
C107	0.01uF; 50V; +-10%	Murata	GRM39B103K50PT	N/A
C108	0.1uF; 16V; +-10%	Murata	GRM39B104K16PT	N/A
C109	0.1uF; 16V; +-10%	Murata	GRM39B104K16PT	N/A
C110	0.001uF; 50V; +-10%	Murata	GRM39B102K50PT	N/A
C111	47uF;6.3V;+-20%	NI-CHEMI	6MCM476MB2TER	N/A
C112	0.1uF; 16V; +-10%	Murata	GRM39B104K16PT	N/A
C113	0.001uF; 50V; +-10%	Murata	GRM39B102K50PT	N/A
C114	47uF;6.3V;+-20%	NI-CHEMI	6MCM476MB2TER	N/A
C115	47uF;6.3V;+-20%	NI-CHEMI	6MCM476MB2TER	N/A
C116	47uF;6.3V;+-20%	NI-CHEMI	6MCM476MB2TER	N/A
C117	NU			
C120	0.001uF; 50V; +-10%	Murata	GRM39B102K50PT	N/A
C129	0.01uF; 50V; +-10%	Murata	GRM39B103K50PT	N/A
C131	33pF; 50V; +-5%	Murata	GRM39CH330J50PT	2113740F39
C132	33pF; 50V; +-5%	Murata	GRM39CH330J50PT	2113740F39
C133	0.001uF; 50V; +-10%	Murata	GRM39B102K50PT	N/A
C134	0.01uF; 50V; +-10%	Murata	GRM39B103K50PT	N/A
C135	2.2pF; 6.3V	Murata	GRM40B225K6.3PT	N/A
C136	NU			
C137	0.1uF; 16V; +-10%	Murata	GRM39B104K16PT	N/A
C138	0.1uF; 16V; +-10%	Murata	GRM39B104K16PT	N/A
C139	0.1uF; 16V; +-10%	Murata	GRM39B104K16PT	N/A
C140	0.22uF; 10V; +-10%	Murata	GRM39B224K10PT	2113928G01
C141	0.001uF; 50V; +-10%	Murata	GRM39B102K50PT	N/A
C142	0.001uF; 50V; +-10%	Murata	GRM39B102K50PT	N/A
C143	0.001uF; 50V; +-10%	Murata	GRM39B102K50PT	N/A
C144	0.001uF; 50V; +-10%	Murata	GRM39B102K50PT	N/A
C145	47pF; 50V; +-5%	Murata	GRM39CH470J50PT	2113740F43
C146	0.001uF; 50V; +-10%	Murata	GRM39B102K50PT	N/A
C147	0.001uF; 50V; +-10%	Murata	GRM39B102K50PT	N/A
C148	0.001uF; 50V; +-10%	Murata	GRM39B102K50PT	N/A
C149	0.001uF; 50V; +-10%	Murata	GRM39B102K50PT	N/A
C150	0.001uF; 50V; +-10%	Murata	GRM39B102K50PT	N/A
C151	0.001uF; 50V; +-10%	Murata	GRM39B102K50PT	N/A
C152	0.001uF; 50V; +-10%	Murata	GRM39B102K50PT	N/A
C153	0.001uF; 50V; +-10%	Murata	GRM39B102K50PT	N/A
C154	0.001uF; 50V; +-10%	Murata	GRM39B102K50PT	N/A
C155	0.001uF; 50V; +-10%	Murata	GRM39B102K50PT	N/A
C156	0.01uF; 50V; +-10%	Murata	GRM39B103K50PT	N/A
C157	0.01uF; 50V; +-10%	Murata	GRM39B103K50PT	N/A
C158	47pF; 50V; +-5%	Murata	GRM39CH470J50PT	2113740F43
C159	47pF; 50V; +-5%	Murata	GRM39CH470J50PT	2113740F43
C160	47pF; 50V; +-5%	Murata	GRM39CH470J50PT	2113740F43

Circuit Ref	Description	Vendor	Vendor Part Number	Motorola Equivalent Part Number
C161	0.001uF; 50V; +-10%	Murata	GRM39B102K50PT	N/A
C162	0.001uF; 50V; +-10%	Murata	GRM39B102K50PT	N/A
C163	0.001uF; 50V; +-10%	Murata	GRM39B102K50PT	N/A
C164	0.01uF; 50V; +-10%	Murata	GRM39B103K50PT	N/A
C165	0.001uF; 50V; +-10%	Murata	GRM39B102K50PT	N/A
C166	47pF; 50V; +-5%	Murata	GRM39CH470J50PT	2113740F43
C167	47pF; 50V; +-5%	Murata	GRM39CH470J50PT	2113740F43
C171	0.1uF; 16V; +-10%	Murata	GRM39B104K16PT	N/A
C173	NU			
C174	1uF; 6.3V; +-10%	Murata	GRM39B105K6.3PT	2113928P04
C175	0.01uF; 50V; +-10%	Murata	GRM39B103K50PT	N/A
C176	0.1uF; 16V; +-10%	Murata	GRM39B104K16PT	N/A
C181	0.22uF; 10V; +-10%	Murata	GRM39B224K10PT	2113928G01
C182	0.22uF; 10V; +-10%	Murata	GRM39B224K10PT	2113928G01
C183	470pF; 50V; +-5%	Murata	GRM39CH471J50PT	N/A
C191	0.001uF; 50V; +-10%	Murata	GRM39B102K50PT	N/A
CN101	Connector	Matsushita	AXK5S40245J/P	DSCN097002
L112	10uH	Taiyo Uden	LEM2520T100J	N/A
LC101	LCD	Picvue	HT138ZAS	DSL170003
M101	Capacitor Microphone	Bosung	OB-22P44	DSMI505001
PB101	CONTROL-PCB	Shikibo	K001C802-12	N/A
Q101	CPU	Sanyo	LC87F72C8A	DSIC092009
Q102	Dual NPN	Rohm	UMG2N TR	N/A
Q105	IC,CPU Reset	Rico	RN5VD30CATR	DSIC076007
Q114	IC, EEPROM	Seiko El.	S-24C16AFJ-01	DSIC510003
Q115	LED	Citizen	CL-200G-C-TS	N/A
Q116	LED	Citizen	CL-200G-C-TS	N/A
Q117	NPN	Rohm	DTC114EETL	N/A
Q118	Green/Red/Amber	Rohm	SML-020MLT T86NN	4804810T02
Q119	Dual NPN	Rohm	UMH6N TR	4880439V02
Q120	IC, DTMF Decoder	Sanyo	LC73881M	DSIC092007
Q121	IC, D/A Converter	Fujitsu	MB88347PFV	DSIC042002
Q122	IC, D Flip-flop	Toshiba	TC7W74FU TE12L	DSIC013029
Q123	PNP	Rohm	DTA144EETL	N/A
Q124	NU			
Q125	IC, Op-Amp	JRC	NJM2107F (TE1)	DSIC025016
Q126	Single	Rohm	RB521S-30 TE61	4805656W22
Q127	Diode	Rohm	1SS355 TE-17	4870360C15
Q130	FET	Toshiba	SSM3K03FE-TE85L	N/A
Q131	Diode	Toshiba	1SS372-TE85L	N/A
R101	0 ohm; 0.1W; +-5%	Rohm	MCR03 EZHJ 000	0662057B47
R102	47 Kohm; 0.1W; +-5%	Rohm	MCR03 EZHJ 473	0662057A89
R103	NU			
R104	0 ohm; 0.1W; +-5%	Rohm	MCR03 EZHJ 000	0662057B47
R105	10 Kohm; 0.1W; +-5%	Rohm	MCR03 EZHJ 103	0662057A73
R106	0 ohm; 0.1W; +-5%	Rohm	MCR03 EZHJ 000	0662057B47
R107	47 ohm; 0.1W; +-5%	Rohm	MCR03 EZHJ 470	0662057A17
R108	330 ohm; 0.1W; +-5%	Rohm	MCR03 EZHJ 331	0662057A37
R109	330 ohm; 0.1W; +-5%	Rohm	MCR03 EZHJ 331	0662057A37
R110	51 Kohm; 0.1W; +-5%	Rohm	MCR03 EZHJ 513	0662057A90
R111	51 Kohm; 0.1W; +-5%	Rohm	MCR03 EZHJ 513	0662057A90

Circuit Ref	Description	Vendor	Vendor Part Number	Motorola Equivalent Part Number
R112	13 Kohm; 0.1W; +-5%	Rohm	MCR03 EZHJ 133	0662057A76
R113	22 Kohm; 0.1W; +-5%	Rohm	MCR03 EZHJ 223	0662057A81
R114	43 Kohm; 0.1W; +-5%	Rohm	MCR03 EZHJ 433	0665027A88
R115	130 Kohm; 0.1W; +-5%	Rohm	MCR03 EZHJ 134	0662257B01
R116	18 Kohm; 0.1W; +-5%	Rohm	MCR03 EZHJ 183	0662057A79
R117	33 Kohm; 0.1W; +-5%	Rohm	MCR03 EZHJ 333	0662057A85
R118	100 Kohm; 0.1W; +-5%	Rohm	MCR03 EZHJ 104	0662057A97
R119	0 ohm; 0.1W; +-5%	Rohm	MCR03 EZHJ 000	0662057B47
R120	0 ohm; 0.1W; +-5%	Rohm	MCR03 EZHJ 000	0662057B47
R121	NU			
R126	10 Kohm; 0.1W; +-5%	Rohm	MCR03 EZHJ 103	0662057A73
R127	12.4 Kohm; 0.1W; +-1%	Rohm	MCR03 EZHF 1242	0662057P69
R128	6.98 Kohm; 0.1W; +-1%	Rohm	MCR03 EZHF 6981	0662057Y24
R129	1 Kohm; 0.1W; +-5%	Rohm	MCR03 EZHJ 102	0662057A49
R134	1 Kohm; 0.1W; +-5%	Rohm	MCR03 EZHJ 102	0662057A49
R135	10 Kohm; 0.1W; +-5%	Rohm	MCR03 EZHJ 103	0662057A73
R136	10 Kohm; 0.1W; +-5%	Rohm	MCR03 EZHJ 103	0662057A73
R137	1 Kohm; 0.1W; +-5%	Rohm	MCR03 EZHJ 102	0662057A49
R138	100 Kohm; 0.1W; +-5%	Rohm	MCR03 EZHJ 104	0662057A97
R141	20 Kohm; 0.1W; +-5%	Rohm	MCR03 EZHJ 203	0662057A80
R142	20 Kohm; 0.1W; +-5%	Rohm	MCR03 EZHJ 203	0662057A80
R143	20 Kohm; 0.1W; +-5%	Rohm	MCR03 EZHJ 203	0662057A80
R144	20 Kohm; 0.1W; +-5%	Rohm	MCR03 EZHJ 203	0662057A80
R145	20 Kohm; 0.1W; +-5%	Rohm	MCR03 EZHJ 203	0662057A80
R146	20 Kohm; 0.1W; +-5%	Rohm	MCR03 EZHJ 203	0662057A80
R147	20 Kohm; 0.1W; +-5%	Rohm	MCR03 EZHJ 203	0662057A80
R148	20 Kohm; 0.1W; +-5%	Rohm	MCR03 EZHJ 203	0662057A80
R150	2.2 Kohm; 0.1W; +-5%	Rohm	MCR03 EZHJ 222	0662057A57
R153	10 Kohm; 0.1W; +-5%	Rohm	MCR03 EZHJ 103	0662057A73
R154	47 Kohm; 0.1W; +-5%	Rohm	MCR03 EZHJ 473	0662057A89
R155	NU			
R156	47 Kohm; 0.1W; +-5%	Rohm	MCR03 EZHJ 473	0662057A89
R157	220 Kohm; 0.1W; +-5%	Rohm	MCR03 EZHJ 224	N/A
R158	470 Kohm; 0.1W; +-5%	Rohm	MCR03 EZHJ 474	0662057B14
R159	20 Kohm; 0.1W; +-5%	Rohm	MCR03 EZHJ 203	0662057A80
R160	10 Kohm; 0.1W; +-5%	Rohm	MCR03 EZHJ 103	0662057A73
R161	10 Kohm; 0.1W; +-5%	Rohm	MCR03 EZHJ 103	0662057A73
R162	10 Kohm; 0.1W; +-5%	Rohm	MCR03 EZHJ 103	0662057A73
R163	10 Kohm; 0.1W; +-5%	Rohm	MCR03 EZHJ 103	0662057A73
R164	10 Kohm; 0.1W; +-5%	Rohm	MCR03 EZHJ 103	0662057A73
R165	10 Kohm; 0.1W; +-5%	Rohm	MCR03 EZHJ 103	0662057A73
R166	10 Kohm; 0.1W; +-5%	Rohm	MCR03 EZHJ 103	0662057A73
R167	47 Kohm; 0.1W; +-5%	Rohm	MCR03 EZHJ 473	0662057A89
R168	47 Kohm; 0.1W; +-5%	Rohm	MCR03 EZHJ 473	0662057A89
R169	330 ohm; 0.1W; +-5%	Rohm	MCR03 EZHJ 331	0662057A37
R170	47 Kohm; 0.1W; +-5%	Rohm	MCR03 EZHJ 473	0662057A89
R171	47 Kohm; 0.1W; +-5%	Rohm	MCR03 EZHJ 473	0662057A89
R172	47 Kohm; 0.1W; +-5%	Rohm	MCR03 EZHJ 473	0662057A89
R173	2.2 Kohm; 0.1W; +-5%	Rohm	MCR03 EZHJ 222	0662057A57
R174	2.2 Kohm; 0.1W; +-5%	Rohm	MCR03 EZHJ 222	0662057A57
R175	4.7 Kohm; 0.1W; +-5%	Rohm	MCR03 EZHJ 472	0662057A65

Circuit Ref	Description	Vendor	Vendor Part Number	Motorola Equivalent Part Number
R176	22 Kohm; 0.1W; +-5%	Rohm	MCR03 EZHJ 223	0662057A81
R177	NU			
R180	10 Kohm; 0.1W; +-5%	Rohm	MCR03 EZHJ 103	0662057A73
R182	0 ohm; 0.1W; +-5%	Rohm	MCR10 EZHJ 000	N/A
R183	47 Kohm; 0.1W; +-5%	Rohm	MCR03 EZHJ 473	0662057A89
R184	10 Kohm; 0.1W; +-5%	Rohm	MCR03 EZHJ 103	0662057A73
R185	470 ohm; 0.1W; +-5%	Rohm	MCR03 EZHJ 471	0662057A41
R186	0 ohm; 0.1W; +-5%	Rohm	MCR03 EZHJ 000	0662057B47
S101	Tact Switch	Motorola	Y39A33110FP	4080523Z01
S102	Tact Switch	Motorola	Y39A33110FP	4080523Z01
X101	Filter, 8.388608 MHz	Daishinkuu	AT-38	DSXT182001

## UHF 435-480 MHz Radio Parts List (RF Board)

Circuit Ref	Description	Vendor	Vendor Part Number	Motorola Equivalent Part Number
C201	0.01uF; 50V; +-10%	Murata	GRM39B103K50PT	N/A
C202	10uF 10V	NI-CHEMI	10MCM106MATER	N/A
C203	1uF 16V	NI-CHEMI	16MC105MATER	N/A
C204	0.01uF; 50V; +-10%	Murata	GRM39B103K50PT	N/A
C205	0.01uF; 50V; +-10%	Murata	GRM39B103K50PT	N/A
C206	0.001uF; 50V; +-10%	Murata	GRM39B102K50PT	N/A
C207	10uF 10V	NI-CHEMI	10MCM106MATER	N/A
C208	0.01uF; 50V; +-10%	Murata	GRM39B103K50PT	N/A
C209	0.001uF; 50V; +-10%	Murata	GRM39B102K50PT	N/A
C210	0.001uF; 50V; +-10%	Murata	GRM39B102K50PT	N/A
C211	0.001uF; 50V; +-10%	Murata	GRM39B102K50PT	N/A
C212	0.001uF; 50V; +-10%	Murata	GRM39B102K50PT	N/A
C213	10uF 10V	NI-CHEMI	10MCM106MATER	N/A
C214	0.001uF; 50V; +-10%	Murata	GRM39B102K50PT	N/A
C215	2.2uF; 16V; +80% -20%	Murata	GRM40F225Z16PT	N/A
C217	0.1uF; 16V; +-10%	Murata	GRM39B104K16PT	N/A
C218	0.001uF; 50V; +-10%	Murata	GRM39B102K50PT	N/A
C219	0.001uF; 50V; +-10%	Murata	GRM39B102K50PT	N/A
C220	100pF; 50V; +-5%	Murata	GRM39CH101J50PT	2113740F51
C301	10uF 10V	NI-CHEMI	10MCM106MATER	N/A
C302	0.1uF; 16V; +-10%	Murata	GRM39B104K16PT	N/A
C303	0.022uF; 50V; +-10%	Murata	GRM39B223K25PT	N/A
C304	10uF; 16V	Ni-Chemi	16MCM106MB2TER	N/A
C305	0.22uF; 10V; +-10%	Murata	GRM39B224K10PT	2113928G05
C306	NU			
C307	NU			
C308	5pF; 50V; +-0.25pF	Murata	GRM39CH050C50PT	N/A
C309	0.01uF; 50V; +-10%	Murata	GRM39B103K50PT	N/A
C310	0.001uF; 50V; +-10%	Murata	GRM39B102K50PT	N/A
C311	1pF; 50V; +-5%	Murata	GRM39CK010C50PT	N/A
C312	10pF; 50V; +-0.5pF	Murata	GRM39CH100D50PT	2113740F27
C314	3pF; 50V; +-0.25pF	Murata	GRM39CH030C50PT	2103689A09
C315	6pF; 50V; +-0.25pF	Murata	GRM39CH060C50PT	N/A
C316	0.001uF; 50V; +-10%	Murata	GRM39B102K50PT	N/A
C317	47pF; 50V; +-5%	Murata	GRM39CH470J50PT	2113740F43
C318	47pF; 50V; +-5%	Murata	GRM39CH470J50PT	2113740F43
C319	47pF; 50V; +-5%	Murata	GRM39CH470J50PT	2113740F43
C320	0.001uF; 50V; +-10%	Murata	GRM39B102K50PT	N/A
C323	1uF 16V	NI-CHEMI	16MC105MATER	N/A
C324	10uF; 16V	Ni-Chemi	16MCM106MB2TER	N/A
C328	4.7uF 16V	NI-CHEMI	16MCM475MATER	N/A
C329	470pF; 50V; +-10%	Murata	GRM39B471K50PT	N/A
C335	10pF	Murata	TZV02Z100A110T00	N/A
C336	33pF; 50V; +-5%	Murata	GRM39UJ330J50PT	N/A
C337	8pF; 50V ; +-0.5pF	Murata	GRM39UJ080D50PT	N/A
C338	10pF; 50V; +-0.5pF	Murata	GRM39UJ100D50PT	N/A
C339	0.001uF; 50V; +-10%	Murata	GRM39B102K50PT	N/A
C340	47pF; 50V; +-5%	Murata	GRM39CH470J50PT	2113740F43
C341	0.1uF; 16V; +-10%	Murata	GRM39B104K16PT	N/A

Circuit Ref	Description	Vendor	Vendor Part Number	Motorola Equivalent Part Number
C342	100pF; 50V; +-5%	Murata	GRM39CH101J50PT	2113740F51
C343	10uF 10V	NI-CHEMI	10MCM106MATER	N/A
C345	0.001uF; 50V; +-10%	Murata	GRM39B102K50PT	N/A
C347	0.001uF; 50V; +-10%	Murata	GRM39B102K50PT	N/A
C350	0.0015uF; 50V; +-10%	Murata	GRM39B152K50PT	N/A
C351	NU			
C352	2pF; 50V; +-10%	Murata	GRM39CH020C50PT	N/A
C353	0.001uF; 50V; +-10%	Murata	GRM39B102K50PT	N/A
C366	1uF 16V	NI-CHEMI	16MC105MATER	N/A
C367	0.0022uF; 50V; +-10%	Murata	GRM39B222K50PT	N/A
C368	1uF; 6.3V; +-10%	Murata	GRM39B105K6.3PT	2113928P04
C369	0.1uF; 35V	NI-CHEMI	35MC104MATER	N/A
C371	1uF 16V	NI-CHEMI	16MC105MATER	N/A
C380	9pF; 50V ; +-0.5pF	Murata	GRM39UJ090D50PT	N/A
C381	NU			
C401	8pF; 50V; +-0.5pF	Murata	GRM39CH080D50PT	N/A
C402	5pF; 50V; +-0.25pF	Murata	GRM39CH050C50PT	N/A
C403	NU			
C404	6pF; 50V; +-0.25pF	Murata	GRM39CH060C50PT	N/A
C405	NU			
C406	100pF; 50V; +-5%	Murata	GRM39CH101J50PT	2113740F51
C407	2pF; 50V; +-5%	Murata	GRM39CK020C50PT	N/A
C408	22pF; 50V; +-5%	Murata	GRM39CH220J50PT	2113740F35
C409	0.01uF; 50V; +-10%	Murata	GRM39B103K50PT	N/A
C410	100pF; 50V; +-5%	Murata	GRM39CH101J50PT	2113740F51
C411	33pF; 50V; +-5%	Murata	GRM39CH330J50PT	2113740F39
C412	0.01uF; 50V; +-10%	Murata	GRM39B103K50PT	N/A
C413	0.01uF; 50V; +-10%	Murata	GRM39B103K50PT	N/A
C414	7pF; 50V; +-0.5pF	Murata	GRM39CH070D50PT	N/A
C415	6pF; 50V; +-0.25pF	Murata	GRM39CH060C50PT	N/A
C416	5pF; 50V; +-0.25pF	Murata	GRM39CH050C50PT	N/A
C417	5pF; 50V; +-0.25pF	Murata	GRM39CH050C50PT	N/A
C419	0.01uF; 50V; +-10%	Murata	GRM39B103K50PT	N/A
C420	3pF; 50V; +-0.25pF	Murata	GRM39CH030C50PT	2103689A09
C421	9pF; 50V; +-0.5pF	Murata	GRM39CH090D50PT	N/A
C422	7pF; 50V; +-0.5pF	Murata	GRM39CH070D50PT	N/A
C423	3pF; 50V; +-0.25pF	Murata	GRM39CH030C50PT	2103689A09
C424	NU			
C425	NU			
C426	82pF; 50V; +-5%	Murata	GRM39CH820J50PT	2113740F49
C427	24pF; 50V; +-5%	Murata	GRM39CH240J50PT	2113740F36
C428	NU			
C429	NU			
C430	0.01uF; 50V; +-10%	Murata	GRM39B103K50PT	N/A
C432	4pF; 50V; +-0.25pF	Murata	GRM39CH040C50PT	N/A
C433	NU			
C435	16pF;50V;+-5%	Murata	GRM39CH160J50PT	2113740F32
C436	NU			
C437	27pF; 50V; +-5%	Murata	GRM39CH270J50PT	2113740F37
C438	100pF; 50V; +-5%	Murata	GRM39CH101J50PT	2113740F51
C439	100pF; 50V; +-5%	Murata	GRM39CH101J50PT	2113740F51

Circuit Ref	Description	Vendor	Vendor Part Number	Motorola Equivalent Part Number
C440	10pF; 50V; +-0.5pF	Murata	GRM39CH100D50PT	2113740F27
C441	1.5pF; 50V; +-5%	Murata	GRM39CK1R5C50PT	N/A
C442	1pF; 50V; +-5%	Murata	GRM39CK010C50PT	N/A
C443	10pF; 50V; +-0.5pF	Murata	GRM39CH100D50PT	2113740F27
C444	6pF; 50V; +-0.25pF	Murata	GRM39CH060C50PT	N/A
C445	100pF; 50V; +-5%	Murata	GRM39CH101J50PT	2113740F51
C446	1uF; 16V; +-10%	Murata	GRM40B105K16PT	N/A
C447	0.0033uF; 50V; +-10%	Murata	GRM39B332K50PT	2155169M15
C448	150pF; 50V; +-5%	Murata	GRM39CH151J50PT	2113740F55
C449	100pF; 50V; +-5%	Murata	GRM39CH101J50PT	2113740F51
C450	47pF; 50V; +-5%	Murata	GRM39CH470J50PT	2113740F43
C451	10pF; 50V; +-0.5pF	Murata	GRM39CH100D50PT	2113740F27
C451	10pF; 50V; +-0.5pF	Murata	GRM39CH100D50PT	2113740F27
C453	100pF; 50V; +-5%	Murata	GRM39CH101J50PT	2113740F51
C454	0.022uF; 50V; +-10%	Murata	GRM39B223K25PT	N/A
C455	330pF; 50V; +-10%	Murata	GRM39B331K50PT	N/A
C456	1uF; 50V; +-10%	Murata	GRM39B105K6.3PT	2113928P04
C457	NU			
C458	15pF; 50V; +-5%	Murata	GRM39CH150J50PT	2113740F31
C459	6pF; 50V; +-0.25pF	Murata	GRM39CH060C50PT	N/A
C460	5pF; 50V; +-0.25pF	Murata	GRM39CH050C50PT	N/A
C461	0.001uF; 50V; +-10%	Murata	GRM39B102K50PT	N/A
C462	0.01uF; 50V; +-10%	Murata	GRM39B103K50PT	N/A
C463	5pF; 50V; +-0.25pF	Murata	GRM39CH050C50PT	N/A
C464	6pF; 50V; +-0.25pF	Murata	GRM39CH060C50PT	N/A
C465	NU			
C466	0.001uF; 50V; +-10%	Murata	GRM39B102K50PT	N/A
C467	0.01uF; 50V; +-10%	Murata	GRM39B103K50PT	N/A
C468	0.001uF; 50V; +-10%	Murata	GRM39B102K50PT	N/A
C469	6.8uF; 6.3V	NI-CHEMI	6MCS685MATER	N/A
C470	5pF; 50V; +-0.25pF	Murata	GRM39CH050C50PT	N/A
C472	0.001uF; 50V; +-10%	Murata	GRM39B102K50PT	N/A
C473	0.001uF; 50V; +-10%	Murata	GRM39B102K50PT	N/A
C474	0.001uF; 50V; +-10%	Murata	GRM39B102K50PT	N/A
C475	5pF; 50V; +-0.25pF	Murata	GRM39CH050C50PT	N/A
C478	5pF; 50V; +-0.25pF	Murata	GRM39CH050C50PT	N/A
C485	2.2uF; 16V; +80% -20%	Murata	GRM40F225Z16PT	N/A
C487	1pF; 50V; +-5%	Murata	GRM39CK010C50PT	N/A
C488	NU			
C489	0.001uF; 50V; +-10%	Murata	GRM39B102K50PT	N/A
C490	NU			
C491	15pF; 50V; +-5%	Murata	GRM39CH150J50PT	2113740F31
C492	2pF; 50V; +-10%	Murata	GRM39CH020C50PT	N/A
C493	150pF; 50V; +-5%	Murata	GRM39CH151J50PT	2113740F55
C494	3pF; 50V; +-0.25pF	Murata	GRM39CH030C50PT	2103689A09
C495	22pF; 50V; +-5%	Murata	GRM39CH220J50PT	2113740F35
C496	18pF; 50V; +-5%	Murata	GRM39CH180J50PT	2113740F33
C497	22pF; 50V; +-5%	Murata	GRM39CH220J50PT	2113740F35
C498	2pF; 50V; +-10%	Murata	GRM39CH020C50PT	N/A
C501	100pF; 50V; +-5%	Murata	GRM39CH101J50PT	2113740F51
C502	NU			

Circuit Ref	Description	Vendor	Vendor Part Number	Motorola Equivalent Part Number
C503	0.1uF; 16V; +-10%	Murata	GRM39B104K16PT	N/A
C504	0.1uF; 16V; +-10%	Murata	GRM39B104K16PT	N/A
C505	100pF; 50V; +-5%	Murata	GRM39CH101J50PT	2113740F51
C506	0.1uF; 16V; +-10%	Murata	GRM39B104K16PT	N/A
C508	470pF; 50V; +-10%	Murata	GRM39B471K50PT	N/A
C509	0.001uF; 50V; +-10%	Murata	GRM39B102K50PT	N/A
C510	0.22uF; 10V; +-10%	Murata	GRM39B224K10PT	2113928G05
C511	0.1uF; 16V; +-10%	Murata	GRM39B104K16PT	N/A
C512	0.0022uF; 50V; +-10%	Murata	GRM39B222K50PT	N/A
C513	27pF; 50V; +-5%	Murata	GRM39CH270J50PT	2113740F37
C514	0.01uF; 50V; +-10%	Murata	GRM39B103K50PT	N/A
C515	0.01uF; 16V; +-2%	Panasonic	ECHU1C103GX5	N/A
C516	0.01uF; 16V; +-2%	Panasonic	ECHU1C103GX5	N/A
C517	0.01uF; 16V; +-2%	Panasonic	ECHU1C103GX5	N/A
C518	0.01uF; 16V; +-2%	Panasonic	ECHU1C103GX5	N/A
C519	0.01uF; 50V; +-10%	Murata	GRM39B103K50PT	N/A
C520	0.01uF; 16V; +-2%	Panasonic	ECHU1C103GX5	N/A
C521	0.01uF; 16V; +-2%	Panasonic	ECHU1C103GX5	N/A
C522	0.01uF; 16V; +-2%	Panasonic	ECHU1C103GX5	N/A
C523	0.22uF; 10V; +-10%	Murata	GRM39B224K10PT	2113928G05
C524	0.068uF; 16V; +-10%	Murata	GRM39B683K16PT	N/A
C525	33pF; 50V; +-5%	Murata	GRM39CH330J50PT	2113740F39
C526	39pF; 50V; +-5%	Murata	GRM39CH390J50PT	2113740F41
C527	0.001uF; 50V; +-10%	Murata	GRM39B102K50PT	N/A
C528	1uF; 6.3V; +-10%	Murata	GRM39B105K6.3PT	2113928P04
C529	0.1uF; 16V; +-10%	Murata	GRM39B104K16PT	N/A
C530	0.1uF; 16V; +-10%	Murata	GRM39B104K16PT	N/A
C531	220pF; 50V; +-10%	Murata	GRM39B221K50PT	N/A
C532	220pF; 50V; +-5%	Murata	GRM39CH221J50PT	N/A
C533	56pF; 50V; +-5%	Murata	GRM39CH560J50PT	2113740F45
C534	2.2uF; 10V	NI-CHEMI	10MCS225MATER	N/A
C535	0.027uF; 25v; +-10%	Murata	GRM39B273K25PT	2155169N29
C536	0.047uF; 16V; +-10%	Murata	GRM39B473K16PT	N/A
C537	0.0027uF; 50V; +-10%	Murata	GRM39B272K50PT	N/A
C538	0.01uF; 50V; +-10%	Murata	GRM39B103K50PT	N/A
C539	0.039uF; 16v; +-10%	Murata	GRM39B393K16PT	N/A
C540	0.0015uF; 50V; +-10%	Murata	GRM39B152K50PT	N/A
C541	0.1uF; 16V; +-10%	Murata	GRM39B104K16PT	N/A
C542	390pF; 50V; +-10%	Murata	GRM39B391K50PT	2113741F15
C543	0.0047uF; 50V; +-10%	Murata	GRM39B472K50PT	N/A
C544	0.22uF; 10V; +-10%	Murata	GRM39B224K10PT	2113928G05
C545	33uF; 6.3V	NI-CHEMI	6MCM336MB2TER	N/A
C546	0.1uF; 16V; +-10%	Murata	GRM39B104K16PT	N/A
C547	0.1uF; 16V; +-10%	Murata	GRM39B104K16PT	N/A
C550	0.01uF; 16V; +-2%	Panasonic	ECHU1C103GX5	N/A
C551	0.01uF; 16V; +-2%	Panasonic	ECHU1C103GX5	N/A
C601	100pF; 50V; +-5%	Murata	GRM39CH101J50PT	2113740F51
C602	0.0033uF; 50V; +-10%	Murata	GRM39B332K50PT	2155169M15
C603	82pF; 50V; +-5%	Murata	GRM39CH820J50PT	2113740F49
C604	0.0012uF; 50V; +-10%	Murata	GRM39B122K50PT	N/A
C605	680pF; 50V; +-10%	Murata	GRM39B681K50PT	N/A



Circuit Ref	Description	Vendor	Vendor Part Number	Motorola Equivalent Part Number
C606	0.1uF; 16V; +-10%	Murata	GRM39B104K16PT	N/A
C607	0.1uF; 16V; +-10%	Murata	GRM39B104K16PT	N/A
C608	NU			
C612	10pF; 50V; +-0.5pF	Murata	GRM39CH100D50PT	2113740F27
C615	0.01uF; 50V; +-10%	Murata	GRM39B103K50PT	N/A
C616	0.027uF; 25v; +-10%	Murata	GRM39B273K25PT	2155169N29
C617	0.0047uF; 50V; +-10%	Murata	GRM39B472K50PT	N/A
C618	82pF; 50V; +-5%	Murata	GRM39CH820J50PT	2113740F49
C619	0.1uF; 16V; +-10%	Murata	GRM39B104K16PT	N/A
C620	NU			
C621	0.001uF; 50V; +-10%	Murata	GRM39B102K50PT	N/A
C622	0.001uF; 50V; +-10%	Murata	GRM39B102K50PT	N/A
C623	0.022uF; 50V; +-10%	Murata	GRM39B223K25PT	N/A
C624	150pF; 50V; +-5%	Murata	GRM39CH151J50PT	2113740F55
C625	4.7uF; 6.3V	NI-CHEMI	6MCS475MATER	N/A
C626	10uF 10V	NI-CHEMI	10MCM106MATER	N/A
C627	0.0033uF; 50V; +-10%	Murata	GRM39B332K50PT	2155169M15
C628	1uF 16V	NI-CHEMI	16MC105MATER	N/A
C629	1uF; 6.3V; +-10%	Murata	GRM39B105K6.3PT	2113928P04
C630	0.015uF; 50V; +-10%	Murata	GRM39B152K50PT	2113932E03
C631	0.0082uF; 50V; +-10%	Murata	GRM39B822K50PT	N/A
C632	68pF; 50V; +-5%	Murata	GRM39CH680J50PT	2113740F47
C633	0.01uF; 50V; +-10%	Murata	GRM39B103K50PT	N/A
C634	0.0018uF; 50V; +-10%	Murata	GRM39B182K50PT	2155116E54
C635	0.1uF; 16V; +-10%	Murata	GRM39B104K16PT	N/A
C636	100pF; 50V; +-5%	Murata	GRM39CH101J50PT	2113740F51
C637	0.001uF; 50V; +-10%	Murata	GRM39B102K50PT	N/A
C638	4.7uF; 6.3V	NI-CHEMI	6MCS475MATER	N/A
C639	27pF; 50V; +-5%	Murata	GRM39CH270J50PT	2113740F37
C641	0.0012uF; 50V; +-10%	Murata	GRM39B122K50PT	N/A
C642	0.022uF; 50V; +-10%	Murata	GRM39B223K25PT	N/A
C643	0.0033uF; 50V; +-10%	Murata	GRM39B332K50PT	2155169M15
C644	1uF; 6.3V; +-10%	Murata	GRM39B105K6.3PT	2113928P04
C645	22pF; 50V; +-5%	Murata	GRM39CH220J50PT	2113740F35
C701	0.001uF; 50V; +-10%	Murata	GRM39B102K50PT	N/A
C702	0.001uF; 50V; +-10%	Murata	GRM39B102K50PT	N/A
C703	0.22uF; 10V; +-10%	Murata	GRM39B224K10PT	2113928G05
C704	4.7uF; 6.3V	NI-CHEMI	6MCS475MATER	N/A
C705	2.2uF; 16V; +80% -20%	Murata	GRM40F225Z16PT	N/A
C706	0.1uF; 16V; +-10%	Murata	GRM39B104K16PT	N/A
C707	0.001uF; 50V; +-10%	Murata	GRM39B102K50PT	N/A
C708	0.001uF; 50V; +-10%	Murata	GRM39B102K50PT	N/A
C709	10uF 10V	NI-CHEMI	10MCM106MATER	N/A
C710	0.1uF; 16V; +-10%	Murata	GRM39B104K16PT	N/A
C711	0.1uF; 16V; +-10%	Murata	GRM39B104K16PT	N/A
C713	0.1uF; 16V; +-10%	Murata	GRM39B104K16PT	N/A
C714	100pF; 50V; +-5%	Murata	GRM39CH101J50PT	2113740F51
C715	100pF; 50V; +-5%	Murata	GRM39CH101J50PT	2113740F51
C716	100pF; 50V; +-5%	Murata	GRM39CH101J50PT	2113740F51
C717	100pF; 50V; +-5%	Murata	GRM39CH101J50PT	2113740F51
C718	100pF; 50V; +-5%	Murata	GRM39CH101J50PT	2113740F51

Circuit Ref	Description	Vendor	Vendor Part Number	Motorola Equivalent Part Number
C719	220pF; 50V; +-5%	Murata	GRM39CH221J50PT	N/A
C720	0.001uF; 50V; +-10%	Murata	GRM39B102K50PT	N/A
C721	0.001uF; 50V; +-10%	Murata	GRM39B102K50PT	N/A
C752	20pF;50V;+-5%	Murata	GRM39CH200J50PT	2113740F34
C912	1pF; 50V; +-5%	Murata	GRM39CK010C50PT	N/A
C913	3pF; 50V; +-0.25pF	Murata	GRM39CH030C50PT	2103689A09
C917	NU			
C918	100pF; 50V; +-5%	Murata	GRM39CH101J50PT	2113740F51
C919	0.022uF; 50V; +-10%	Murata	GRM39B223K25PT	N/A
C935	6pF; 50V; +-0.25pF	Murata	GRM39CH060C50PT	N/A
C936	6pF; 50V; +-0.25pF	Murata	GRM39CH060C50PT	N/A
C937	6pF; 50V; +-0.25pF	Murata	GRM39CH060C50PT	N/A
C938	2pF; 50V; +-10%	Murata	GRM39CH020C50PT	N/A
C939	NU			
C940	NU			
CD501	Discriminator	Samsung	IFD0455C24E03	N/A
CN201	Connector contact Battery	Motorola	09D86237A	0986237A01
CN701	Connector	Matsushita	AXK6S40545J/P	DSCN097003
F401	NU			
F402	Filter , 45.1 MHz	HERTZ	45N12A5 (45.1MHz) UM-5J-SMD	DSXF137006
F501	Ceramic filter	Toko	BLFYM455D	N/A
F502	455Khz	TOKO	ALFYM455G	N/A
J401	Antenna Jack	Motorola	02D80689C	0280689C01
J701	Audio Jack	Motorola	09R80683Z	0980683Z01
J702	Connector	Molex	53047-0210	N/A
L301	22nH	TOKO	LL1608-FS22NJ	N/A
L302	390nH	Sagami Elec	C2012C-R39J	2462587V41
L303	18nH	Sagami Elec	C2012C-18NG	N/A
L304	390nH	Sagami Elec	C2012C-R39J	2462587V41
L305	390nH	Sagami Elec	C2012C-R39J	2462587V41
L306	390nH	Sagami Elec	C2012C-R39J	2462587V41
L307	390nH	Sagami Elec	C2012C-R39J	2462587V41
L308	390nH	Sagami Elec	C2012C-R39J	2462587V41
L309	18nH	Sagami Elec	C2012C-18NG	N/A
L310	390nH	Sagami Elec	C2012C-R39J	2462587V41
L312	Chip emifil	Murata	BLM21A121SPT	2480067M02
L313	1000uH	TDK	NL453232T-102J	N/A
L401	Airwound Coil	Uchida/Latest	E2-0.30-1.0-5TL	N/A
L402	Airwound Coil	Uchida/Latest	E2-0.30-1.0-5TL	N/A
L403	NU			
L404	180nH	Sagami Elec	C2012C-R15J	2462587V36
L405	Airwound Coil	Uchida/Latest	E2-0.30-1.0-7TL	N/A
L406	Airwound Coil	Uchida/Latest	E2-0.30-1.0-5TL	N/A
L407	Airwound Coil	Uchida/Latest	E2-0.30-1.0-5TL	N/A
L408	Coil	Latest	SMD-0314A	N/A
L409	Coil	Latest	SMD-0314A	N/A
L410	15nH	TOKO	LL2012-FH15NJ	N/A
L411	0 ohm; 0.1W; +-5%	Rohm	MCR10 EZH J 000	0662057C01
L412	150nH	Sagami Elec	C2012C-R15J (150nH)	N/A
L413	470nH	Toko	FSLM2520-R47K	2485602J33

Circuit Ref	Description	Vendor	Vendor Part Number	Motorola Equivalent Part Number
L414	Airwound Coil	Uchida/Latest	E2-0.40-1.0-5TL	N/A
L415	Airwound Coil	Uchida/Latest	E2-0.40-1.0-5TL	N/A
L416	Airwound Coil	Uchida/Latest	E2-0.40-1.0-5TL	N/A
L417	390nH	Sagami Elec	C2012C-R39J	2462587V41
L418	Airwound Coil	Uchida/Latest	E2-0.40-0.8-2TL	N/A
L419	Airwound Coil	Uchida/Latest	E2-0.40-1.0-5TL	N/A
L420	Airwound Coil	Uchida/Latest	E2-0.30-1.0-7TL	N/A
L421	Airwound Coil	Uchida/Latest	E2-0.40-0.9-3TL	N/A
L422	Airwound Coil	Uchida/Latest	E2-0.30-1.0-7TL	N/A
L423	Airwound Coil	Uchida/Latest	E2-0.40-0.9-3TL	N/A
L424	18nH	TOKO	LL1608-FS18NJ	N/A
L425	18nH	TOKO	LL1608-FS18NJ	N/A
L426	22nH	TOKO	LL1608-FS22NJ	N/A
L427	Chip Beads	TDK	ZBFS5105-PT	N/A
L428	NU			
L430	Airwound Coil	Uchida/Latest	E2-0.30-1.0-4TL	4880048M03
L431	1uH	TDK	MLF1608A1R0KT	N/A
L432	1uH	TDK	MLF1608A1R0KT	N/A
L501	1uH	TDK	MLF1608A1R0KT	N/A
L702	390nH	Sagami Elec	C2012C-R39J	2462587V41
P701	SP WIRE Assembly	EU-connector	WC-013	N/A
PB201	RF-VHF-PCB	Shikibo	K001C803-6	N/A
Q201	PNP	NEC	2SB798-T1 DK	N/A
Q202	Digital transistor	Rohm	UMW1N TL	N/A
Q203	Single	Rohm	1SR154-400 TE25	4842006M02
Q204	IC	Torex	XC62HR5002PR	DSIC510004
Q206	PNP	Rohm	DTA123YETL	N/A
Q207	Digital transistor	Rohm	UMW1N TL	N/A
Q208	PNP	Rohm	DTA114EETL	4808317Y01
Q209	Digital transistor	Rohm	DTC114EETL	N/A
Q210	PNP	Toshiba	2SA1362-GR TE85L	N/A
Q211	PNP	Rohm	DTA123YETL	N/A
Q301	IC	TOKO	TK11816M	DSIC011011
Q302	FET	NEC	2SK508-T1B K52	N/A
Q303	FET	NEC	2SK508-T1B K52	N/A
Q308	NPN	Toshiba	2SC5086-Y TE85L	N/A
Q311	Var. Cap. Diode	Toshiba	1SV228-TPH3	N/A
Q314	Transistor	Toshiba	2SA1586-GR TE85L	N/A
Q315	NPN	Toshiba	2SC4116-GR TE85L	N/A
Q316	Zener ;7.6V	Rohm	UDZ S 7.5B TE-17	N/A
Q317	Digital transistor	Rohm	UMC4N TR	N/A
Q318	NPN	Toshiba	2SC4116-GR TE85L	N/A
Q319	Single	Rohm	1SS355 TE-17	4870360C15
Q320	Transistor	Rohm	UMZ2N-TR	4809939C06
Q322	Var. Cap. Diode	Toshiba	1SV217-TPH3	N/A
Q323	IC	Fujitsu	MB15A02PFV1-ER	DSIC042003
Q331	NPN	Toshiba	2SC4116-GR TE85L	N/A
Q401	Var. Cap. Diode	Toshiba	1SV279-TPH3	N/A
Q402	Var. Cap. Diode	Toshiba	1SV279-TPH3	N/A
Q403	Dual Varactor	Toshiba	1SS362-TE85L	N/A
Q404	NPN	Toshiba	2SC5086-Y TE85L	N/A

Circuit Ref	Description	Vendor	Vendor Part Number	Motorola Equivalent Part Number
Q405	Var. Cap. Diode	Toshiba	1SV279-TPH3	N/A
Q406	Var. Cap. Diode	Toshiba	1SV279-TPH3	N/A
Q407	Diode	HP	HSMS-2817	N/A
Q408	Transistor	Toshiba	2SC4215-Y TE85L	N/A
Q409	Single	Hitachi	HVU131TRF	N/A
Q410	Diode	MA/COM	MA4PH262	N/A
Q411	FET	Toshiba	2SK3476	DSTR013027
Q412	FET	Toshiba	2SK3475	DSTR013026
Q413	NPN	NEC	2SC3356-T1B R24	N/A
Q414	NPN	Toshiba	2SC5086-Y TE85L	N/A
Q415	Single	Hitachi	HSC277TRF	N/A
Q416	NPN	Toshiba	2SC5086-Y TE85L	N/A
Q417	Digital transistor	Rohm	DTC114EETL	N/A
Q418	Digital transistor	Rohm	DTC144EETL	4880048M03
Q419	IC, Op-Amp	JRC	NJM2904V(TE1)	DSIC510001
Q420	NU			
Q501	Digital transistor	Rohm	UMC4N TR	N/A
Q502	IC, Op-Amp	JRC	NJM324V(TE1)	DSIC510002
Q503	FET	Toshiba	2SJ144Y-TE85L	N/A
Q504	Digital transistor	Rohm	DTC144EETL	4880048M03
Q505	IC, Op-Amp	JRC	NJM324V(TE1)	DSIC510002
Q506	IC	Toshiba	TA31136FN-TP1	DSIC013007
Q507	Dual	Rohm	DAN235ETL	N/A
Q508	Dual	Rohm	DAN235ETL	N/A
Q509	PNP	Rohm	DTA144EETL	N/A
Q510	IC, Op-Amp	JRC	NJM2107F (TE1)	DSIC025016
Q511	Diode	Rohm	RB521S-30 TE61	N/A
Q601	Digital transistor	Rohm	DTC144EETL	4880048M03
Q602	IC, Op-Amp	JRC	NJM324V(TE1)	DSIC510002
Q605	Digital transistor	Rohm	DTC144EETL	4880048M03
Q607	NU			
Q608	Digital transistor	Rohm	DTC144EETL	4880048M03
Q609	Digital transistor	Rohm	UMG2N TR	N/A
Q610	IC, Op-Amp	JRC	NJM324V(TE1)	DSIC510002
Q613	PNP	Rohm	DTA144EETL	N/A
Q614	Diode	Toshiba	1SS372-TE85L	N/A
Q615	Dual	Rohm	DAN222TL	4809606E02
Q616	FET	Toshiba	SSM3K03FE-TE85L	N/A
Q617	IC, Op-Amp	JRC	NJM2107F (TE1)	DSIC025016
Q701	Digital transistor	Rohm	DTC144EETL	4880048M03
Q702	IC	Philips	TDA8541T/N1	DSIC174004
Q703	Digital transistor	Rohm	DTC144EETL	4880048M03
Q704	Transistor	Toshiba	2SA1586-GR TE85L	N/A
Q705	Single	Rohm	1SR154-400 TE25	4842006M02
Q706	Zener;6.9V	Rohm	UDZ S 6.8B TE-17	4842006M03
Q707	PNP	Toshiba	2SA1313-Y TE85L	N/A
Q708	Transistor	Toshiba	2SA1586-GR TE85L	N/A
Q709	Transistor	Toshiba	2SA1586-GR TE85L	N/A
Q710	Zener;20.39V	Rohm	UDZ S 20B TE-17	N/A
Q711	Single	Rohm	1SR154-400 TE25	4842006M02
Q712	Single	Rohm	1SS355 TE-17	4870360C15

Circuit Ref	Description	Vendor	Vendor Part Number	Motorola Equivalent Part Number
Q916	FET	NEC	2SJ243-T1	N/A
Q921	Var. Cap. Diode	Toshiba	JDV2S01E-TPH3	N/A
Q922	Var. Cap. Diode	Toshiba	1SV270-TPH3	N/A
R201	10 Kohm; 0.1W; +-5%	Rohm	MCR03 EZHJ 103	0662057A73
R202	2.2 Kohm; 0.1W; +-5%	Rohm	MCR03 EZHJ 222	0662057A57
R203	4.7 Kohm; 0.1W; +-5%	Rohm	MCR03 EZHJ 472	0662057A65
R204	4.7 Kohm; 0.1W; +-5%	Rohm	MCR03 EZHJ 472	0662057A65
R205	50K ohm	Hokuriku	NSM3503J400J	N/A
R206	NU			
R207	10 Kohm; 0.1W; +-5%	Rohm	MCR03 EZHJ 103	0662057A73
R208	4.7 Kohm; 0.1W; +-5%	Rohm	MCR03 EZHJ 472	0662057A65
R209	10 ohm; 0.1W; +-5%	Rohm	MCR03 EZHJ 100	0662057A01
R210	22 ohm; 0.1W; +-5%	Rohm	MCR03 EZHJ 220	0662057A09
R211	10 Kohm; 0.1W; +-5%	Rohm	MCR03 EZHJ 103	0662057A73
R212	100 ohm; 0.1W; +-5%	Rohm	MCR03 EZHJ 101	0662057A25
R301	1 Kohm; 0.1W; +-5%	Rohm	MCR03 EZHJ 102	0662057A49
R302	220 ohm; 0.1W; +-5%	Rohm	MCR03 EZHJ 221	0662057A33
R310	100 ohm; 0.1W; +-5%	Rohm	MCR03 EZHJ 101	0662057A25
R311	15 Kohm; 0.1W; +-5%	Rohm	MCR03 EZHJ 153	0662057A77
R312	220 ohm; 0.1W; +-5%	Rohm	MCR03 EZHJ 221	0662057A33
R313	100 Kohm; 0.1W; +-5%	Rohm	MCR03 EZHJ 104	0662057A97
R314	0 ohm; 0.1W; +-5%	Rohm	MCR03 EZHJ 000	0662057B47
R315	3.3 Kohm; 0.1W; +-5%	Rohm	MCR03 EZHJ 332	0662057A61
R316	2.7 Kohm; 0.1W; +-5%	Rohm	MCR03 EZHJ 272	0662057A59
R317	3.3 Kohm; 0.1W; +-5%	Rohm	MCR03 EZHJ 332	0662057A61
R318	10 Kohm; 0.1W; +-5%	Rohm	MCR03 EZHJ 103	0662057A73
R319	10 Kohm; 0.1W; +-5%	Rohm	MCR03 EZHJ 103	0662057A73
R320	6.8 Kohm; 0.1W; +-5%	Rohm	MCR03 EZHJ 682	0662057A69
R321	6.8 Kohm; 0.1W; +-5%	Rohm	MCR03 EZHJ 682	0662057A69
R323	Chip network resistor	Hokuriku	CRA168-472J	DSRA508001
R325	10 Kohm; 0.1W; +-5%	Rohm	MCR03 EZHJ 103	0662057A73
R327	100 Kohm; 0.1W; +-5%	Rohm	MCR03 EZHJ 104	0662057A97
R329	220 Kohm; 0.1W; +-1%	Rohm	MCR03 EZHF 2203	N/A
R330	10K ohm	Murata	NTH5G16P39A103K07 TH	N/A
R332	100 Kohm; 0.1W; +-1%	Rohm	MCR03 EZHF 1003	0662057P95
R333	100 Kohm; 0.1W; +-5%	Rohm	MCR03 EZHJ 104	0662057A97
R335	100 Kohm; 0.1W; +-5%	Rohm	MCR03 EZHJ 104	0662057A97
R336	100 Kohm; 0.1W; +-5%	Rohm	MCR03 EZHJ 104	0662057A97
R337	150 Kohm; 0.1W; +-1%	Rohm	MCR03 EZHF 1503	0662057P97
R355	NU			
R356	4.7 Kohm; 0.1W; +-5%	Rohm	MCR03 EZHJ 472	0662057A65
R357	10 ohm; 0.1W; +-5%	Rohm	MCR03 EZHJ 100	0662057A01
R358	47 ohm; 0.1W; +-5%	Rohm	MCR03 EZHJ 470	0662057A17
R359	4.7 Kohm; 0.1W; +-5%	Rohm	MCR03 EZHJ 472	0662057A65
R361	22 Kohm; 0.1W; +-5%	Rohm	MCR03 EZHJ 223	0662057A81
R362	22 Kohm; 0.1W; +-5%	Rohm	MCR03 EZHJ 223	0662057A81
R364	6.8 Kohm; 0.1W; +-5%	Rohm	MCR03 EZHJ 682	0662057A69
R366	470 ohm; 0.1W; +-5%	Rohm	MCR03 EZHJ 471	0662057A41
R367	470 ohm; 0.1W; +-5%	Rohm	MCR03 EZHJ 471	0662057A41
R368	100 Kohm; 0.1W; +-5%	Rohm	MCR03 EZHJ 104	0662057A97

Circuit Ref	Description	Vendor	Vendor Part Number	Motorola Equivalent Part Number
R401	100 Kohm; 0.1W; +-5%	Rohm	MCR03 EZHJ 104	0662057A97
R402	100 Kohm; 0.1W; +-5%	Rohm	MCR03 EZHJ 104	0662057A97
R403	12 Kohm; 0.1W; +-5%	Rohm	MCR03 EZHJ 123	0662057A51
R404	4.7 Kohm; 0.1W; +-5%	Rohm	MCR03 EZHJ 472	0662057A65
R405	6.8 Kohm; 0.1W; +-5%	Rohm	MCR03 EZHJ 682	0662057A69
R406	0 ohm; 0.1W; +-5%	Rohm	MCR03 EZHJ 000	0662057B47
R407	470 ohm; 0.1W; +-5%	Rohm	MCR03 EZHJ 471	0662057A41
R408	100 Kohm; 0.1W; +-5%	Rohm	MCR03 EZHJ 104	0662057A97
R409	100 Kohm; 0.1W; +-5%	Rohm	MCR03 EZHJ 104	0662057A97
R410	100 Kohm; 0.1W; +-5%	Rohm	MCR03 EZHJ 104	0662057A97
R412	56 ohm; 0.1W; +-5%	Rohm	MCR03 EZHJ 560	0662057A19
R413	0 ohm; 0.1W; +-5%	Rohm	MCR03 EZHJ 000	0662057B47
R415	150 Kohm; 0.1W; +-5%	Rohm	MCR03 EZHJ 154	0662057B02
R416	NU			
R417	220 ohm; 0.1W; +-5%	Rohm	MCR03 EZHJ 221	0662057A33
R418	470 ohm; 0.1W; +-5%	Rohm	MCR03 EZHJ 471	0662057A41
R419	56 ohm; 0.1W; +-5%	Rohm	MCR03 EZHJ 560	0662057A19
R420	33 Kohm; 0.1W; +-5%	Rohm	MCR03 EZHJ 333	0662057A85
R421	22 Kohm; 0.1W; +-5%	Rohm	MCR03 EZHJ 223	0662057A81
R422	470 ohm; 0.1W; +-5%	Rohm	MCR03 EZHJ 471	0662057A41
R423	100 ohm; 0.1W; +-5%	Rohm	MCR03 EZHJ 101	0662057A25
R424	1 Kohm; 0.1W; +-5%	Rohm	MCR03 EZHJ 102	0662057A49
R425	100 Kohm; 0.1W; +-5%	Rohm	MCR03 EZHJ 104	0662057A97
R426	NU			
R427	22 ohm; 0.1W; +-5%	Rohm	MCR03 EZHJ 220	0662057A09
R428	820 Kohm; 0.1W; +-5%	Rohm	MCR03 EZHJ 824	0662057B20
R429	4.7 Kohm; 0.1W; +-5%	Rohm	MCR03 EZHJ 472	0662057A65
R430	100 ohm; 0.1W; +-5%	Rohm	MCR03 EZHJ 101	0662057A25
R431	10 Kohm; 0.1W; +-5%	Rohm	MCR03 EZHJ 103	0662057A73
R432	220 ohm; 0.1W; +-5%	Rohm	MCR03 EZHJ 221	0662057A33
R433	10 Kohm; 0.1W; +-5%	Rohm	MCR03 EZHJ 103	0662057A73
R434	100 ohm; 0.1W; +-5%	Rohm	MCR03 EZHJ 101	0662057A25
R435	2.2 ohm; 0.1W; +-5%	Rohm	MCR03 EZHJ 2R2	0662057W09
R436	10 Kohm; 0.1W; +-5%	Rohm	MCR03 EZHJ 103	0662057A73
R437	4.7 Kohm; 0.1W; +-5%	Rohm	MCR03 EZHJ 472	0662057A65
R438	1 Kohm; 0.1W; +-5%	Rohm	MCR03 EZHJ 102	0662057A49
R439	330 ohm; 0.1W; +-5%	Rohm	MCR03 EZHJ 331	0662057A37
R440	22 ohm; 0.1W; +-5%	Rohm	MCR03 EZHJ 220	0662057A09
R441	330 ohm; 0.1W; +-5%	Rohm	MCR03 EZHJ 331	0662057A37
R442	0.1ohm 1W	Hokuriku	LPR1R100FE	N/A
R443	100 Kohm; 0.1W; +-1%	Rohm	MCR03 EZHF 1003	0662057P95
R444	100 Kohm; 0.1W; +-1%	Rohm	MCR03 EZHF 1003	0662057P95
R445	100 Kohm; 0.1W; +-1%	Rohm	MCR03 EZHF 1003	0662057P95
R446	100 Kohm; 0.1W; +-1%	Rohm	MCR03 EZHF 1003	0662057P95
R447	97.6 Kohm; 0.1W; +-1%	Rohm	MCR03 EZHF 9762	N/A
R448	100 Kohm; 0.1W; +-5%	Rohm	MCR03 EZHJ 104	0662057A97
R449	100 Kohm; 0.1W; +-1%	Rohm	MCR03 EZHF 1003	0662057P95
R450	10 Kohm; 0.1W; +-5%	Rohm	MCR03 EZHJ 103	0662057A73
R451	100 Kohm; 0.1W; +-5%	Rohm	MCR03 EZHJ 104	0662057A97
R452	33 Kohm; 0.1W; +-5%	Rohm	MCR03 EZHJ 333	0662057A85
R453	1 Mohm; 0.1W; +-5%	Rohm	MCR03 EZHJ 105	0662057B22

Circuit Ref	Description	Vendor	Vendor Part Number	Motorola Equivalent Part Number
R454	15 Kohm; 0.1W; +-5%	Rohm	MCR03 EZHJ 153	0662057A77
R455	100 Kohm; 0.1W; +-5%	Rohm	MCR03 EZHJ 104	0662057A97
R459	3.3 Kohm; 0.1W; +-5%	Rohm	MCR03 EZHJ 332	0662057A61
R466	1 Kohm; 0.1W; +-5%	Rohm	MCR03 EZHJ 102	0662057A49
R468	1 Kohm; 0.1W; +-5%	Rohm	MCR03 EZHJ 102	0662057A49
R469	2.2 Kohm; 0.1W; +-5%	Rohm	MCR03 EZHJ 222	0662057A57
R501	0 ohm; 0.1W; +-5%	Rohm	MCR03 EZHJ 000	0662057B47
R502	47 Kohm; 0.1W; +-5%	Rohm	MCR03 EZHJ 473	0662057A89
R503	2.7 Kohm; 0.1W; +-5%	Rohm	MCR03 EZHJ 272	0662057A59
R505	2.2 Kohm; 0.1W; +-5%	Rohm	MCR03 EZHJ 222	0662057A57
R506	3.3 Kohm; 0.1W; +-5%	Rohm	MCR03 EZHJ 332	0662057A61
R507	1 Kohm; 0.1W; +-5%	Rohm	MCR03 EZHJ 102	0662057A49
R508	10 Kohm; 0.1W; +-5%	Rohm	MCR03 EZHJ 103	0662057A73
R509	68 Kohm; 0.1W; +-5%	Rohm	MCR03 EZHJ 683	0662057A93
R510	470 Kohm; 0.1W; +-5%	Rohm	MCR03 EZHJ 474	0662057B14
R511	56 Kohm; 0.1W; +-5%	Rohm	MCR03 EZHJ 563	0662057A91
R512	47 Kohm; 0.1W; +-5%	Rohm	MCR03 EZHJ 473	0662057A89
R513	10 Kohm; 0.1W; +-5%	Rohm	MCR03 EZHJ 103	0662057A73
R514	1 Kohm; 0.1W; +-5%	Rohm	MCR03 EZHJ 102	0662057A49
R515	25.5 Kohm; 0.1W; +-1%	Rohm	MCR03 EZHF 2552	0662057T92
R516	29.4 Kohm; 0.1W; +-1%	Rohm	MCR03 EZHF 2942	0662057P29
R517	15.8 Kohm; 0.1W; +-1%	Rohm	MCR03 EZHF 1582	0662057Z03
R518	11.5 Kohm; 0.1W; +-1%	Rohm	MCR03 EZHF 1152	0662057Z35
R519	150 Kohm; 0.1W; +-1%	Rohm	MCR03 EZHF 1503	0662057P97
R520	4.22 Kohm; 0.1W; +-1%	Rohm	MCR03 EZHF 4221	N/A
R521	715 Kohm; 0.1W; +-1%	Rohm	MCR03 EZHF 7153	0662057T99
R522	NU			
R523	47 Kohm; 0.1W; +-5%	Rohm	MCR03 EZHJ 473	0662057A89
R524	2.2 Kohm; 0.1W; +-5%	Rohm	MCR03 EZHJ 222	0662057A57
R525	10 Kohm; 0.1W; +-5%	Rohm	MCR03 EZHJ 103	0662057A73
R526	0 ohm; 0.1W; +-5%	Rohm	MCR03 EZHJ 000	0662057B47
R527	10 Kohm; 0.1W; +-5%	Rohm	MCR03 EZHJ 103	0662057A73
R530	22 Kohm; 0.1W; +-5%	Rohm	MCR03 EZHJ 223	0662057A81
R531	22 Kohm; 0.1W; +-5%	Rohm	MCR03 EZHJ 223	0662057A81
R532	1.5 Mohm; 0.1W; +-5%	Rohm	MCR03 EZHJ 155	N/A
R534	330 Kohm; 0.1W; +-5%	Rohm	MCR03 EZHJ 334	0662057B10
R535	2.2 Kohm; 0.1W; +-5%	Rohm	MCR03 EZHJ 222	0662057A57
R536	1 Kohm; 0.1W; +-5%	Rohm	MCR03 EZHJ 102	0662057A49
R537	470 Kohm; 0.1W; +-5%	Rohm	MCR03 EZHJ 474	0662057B14
R538	100 Kohm; 0.1W; +-5%	Rohm	MCR03 EZHJ 104	0662057A97
R539	100 Kohm; 0.1W; +-5%	Rohm	MCR03 EZHJ 104	0662057A97
R540	22 Kohm; 0.1W; +-5%	Rohm	MCR03 EZHJ 223	0662057A81
R541	22 Kohm; 0.1W; +-5%	Rohm	MCR03 EZHJ 223	0662057A81
R542	22 Kohm; 0.1W; +-5%	Rohm	MCR03 EZHJ 223	0662057A81
R543	100 Kohm; 0.1W; +-5%	Rohm	MCR03 EZHJ 104	0662057A97
R544	100 Kohm; 0.1W; +-5%	Rohm	MCR03 EZHJ 104	0662057A97
R545	100 Kohm; 0.1W; +-5%	Rohm	MCR03 EZHJ 104	0662057A97
R546	100 Kohm; 0.1W; +-5%	Rohm	MCR03 EZHJ 104	0662057A97
R547	100 Kohm; 0.1W; +-5%	Rohm	MCR03 EZHJ 104	0662057A97
R548	10 Kohm; 0.1W; +-5%	Rohm	MCR03 EZHJ 103	0662057A73
R549	100 Kohm; 0.1W; +-5%	Rohm	MCR03 EZHJ 104	0662057A97

Circuit Ref	Description	Vendor	Vendor Part Number	Motorola Equivalent Part Number
R550	1 Kohm; 0.1W; +-5%	Rohm	MCR03 EZHJ 102	0662057A49
R551	0 ohm; 0.1W; +-5%	Rohm	MCR03 EZHJ 000	0662057B47
R560	5.6 Kohm; 0.1W; +-1%	Rohm	MCR03 EZHF 562	N/A
R561	634 Kohm; 0.1W; +-5%	Rohm	MCR03 EZHF 6343	N/A
R563	0 ohm; 0.1W; +-5%	Rohm	MCR03 EZHJ 000	0662057B47
R564	82 Kohm; 0.1W; +-1%	Rohm	MCR03 EZHF 8202	N/A
R565	18 Kohm; 0.1W; +-5%	Rohm	MCR03 EZHJ 183	0662057A79
R566	6.8 Kohm; 0.1W; +-5%	Rohm	MCR03 EZHJ 682	0662057A69
R567	10K ohm	Murata	NTH5G16P39A103K07 TH	N/A
R568	4.7 Kohm; 0.1W; +-5%	Rohm	MCR03 EZHJ 472	0662057A65
R569	1 Kohm; 0.25W; +-5%	Hokuriku	CR1/4-102J	N/A
R570	120 Kohm; 0.1W; +-5%	Rohm	MCR03 EZHJ 124	N/A
R571	220 Kohm	MURATA	NCP18WM224K03RB	N/A
R601	2.2 Mohm; 0.1W; +-5%	Rohm	MCR03 EZHJ 225	N/A
R602	6.8 Kohm; 0.1W; +-5%	Rohm	MCR03 EZHJ 682	0662057A69
R604	6.8 Kohm; 0.1W; +-5%	Rohm	MCR03 EZHJ 682	0662057A69
R605	100 Kohm; 0.1W; +-5%	Rohm	MCR03 EZHJ 104	0662057A97
R606	100 Kohm; 0.1W; +-5%	Rohm	MCR03 EZHJ 104	0662057A97
R607	100 Kohm; 0.1W; +-5%	Rohm	MCR03 EZHJ 104	0662057A97
R608	100 Kohm; 0.1W; +-5%	Rohm	MCR03 EZHJ 104	0662057A97
R609	680 Kohm; 0.1W; +-5%	Rohm	MCR03 EZHJ 684	0662057B18
R610	10 Kohm; 0.1W; +-5%	Rohm	MCR03 EZHJ 103	0662057A73
R611	50K ohm	Hokuriku	NSM3503J400J	N/A
R612	47 Kohm; 0.1W; +-5%	Rohm	MCR03 EZHJ 473	0662057A89
R615	12 Kohm; 0.1W; +-5%	Rohm	MCR03 EZHJ 123	0662057A51
R616	4.7 Kohm; 0.1W; +-5%	Rohm	MCR03 EZHJ 472	0662057A65
R617	100 Kohm; 0.1W; +-5%	Rohm	MCR03 EZHJ 104	0662057A97
R620	4.7 Kohm; 0.1W; +-5%	Rohm	MCR03 EZHJ 472	0662057A65
R621	330 Kohm; 0.1W; +-5%	Rohm	MCR03 EZHJ 334	0662057B10
R622	0 ohm; 0.1W; +-5%	Rohm	MCR03 EZHJ 000	0662057B47
R625	18 Kohm; 0.1W; +-5%	Rohm	MCR03 EZHJ 183	0662057A79
R626	18 Kohm; 0.1W; +-5%	Rohm	MCR03 EZHJ 183	0662057A79
R627	680 Kohm; 0.1W; +-5%	Rohm	MCR03 EZHJ 684	0662057B18
R628	0 ohm; 0.1W; +-5%	Rohm	MCR03 EZHJ 000	0662057B47
R629	NU			
R631	NU			
R633	18 Kohm; 0.1W; +-5%	Rohm	MCR03 EZHJ 183	0662057A79
R634	680 Kohm; 0.1W; +-5%	Rohm	MCR03 EZHJ 684	0662057B18
R635	1.5 Mohm; 0.1W; +-5%	Rohm	MCR03 EZHJ 155	N/A
R635	3.3 Mohm; 0.1W; +-5%	Rohm	MCR03 EZHJ 335	0662057B34
R636	0 ohm; 0.1W; +-5%	Rohm	MCR03 EZHJ 000	0662057B47
R637	0 ohm; 0.1W; +-5%	Rohm	MCR03 EZHJ 000	0662057B47
R638	270 Kohm; 0.1W; +-5%	Rohm	MCR03 EZHJ 274	NA
R639	270 Kohm; 0.1W; +-5%	Rohm	MCR03 EZHJ 274	NA
R640	180 Kohm; 0.1W; +-5%	Rohm	MCR03 EZHJ 184	N/A
R641	100 Kohm; 0.1W; +-5%	Rohm	MCR03 EZHJ 104	0662057A97
R642	33 Kohm; 0.1W; +-1%	Rohm	MCR03 EZHF 3302	N/A
R643	22 Kohm; 0.1W; +-1%	Rohm	MCR03 EZHF 2202	N/A
R645	1 Mohm; 0.1W; +-5%	Rohm	MCR03 EZHJ 105	0662057B22
R646	1 Kohm; 0.1W; +-5%	Rohm	MCR03 EZHJ 102	0662057A49

Circuit Ref	Description	Vendor	Vendor Part Number	Motorola Equivalent Part Number
R648	470 Kohm; 0.1W; +-5%	Rohm	MCR03 EZHJ 474	0662057B14
R649	100 Kohm; 0.1W; +-5%	Rohm	MCR03 EZHJ 104	0662057A97
R650	100 Kohm; 0.1W; +-5%	Rohm	MCR03 EZHJ 104	0662057A97
R651	100 Kohm; 0.1W; +-5%	Rohm	MCR03 EZHJ 104	0662057A97
R652	680 Kohm; 0.1W; +-5%	Rohm	MCR03 EZHJ 684	0662057B18
R655	4.7 Kohm; 0.1W; +-5%	Rohm	MCR03 EZHJ 472	0662057A65
R656	100 ohm; 0.1W; +-5%	Rohm	MCR03 EZHJ 101	0662057A25
R657	0 ohm; 0.1W; +-5%	Rohm	MCR03 EZHJ 000	0662057B47
R658	820 ohm; 0.1W; +-5%	Rohm	MCR03 EZHJ 821	0662057A47
R659	12 Kohm; 0.1W; +-5%	Rohm	MCR03 EZHJ 123	0662057A51
R660	NU			
R661	10 Kohm; 0.1W; +-5%	Rohm	MCR03 EZHJ 103	0662057A73
R663	100 Kohm; 0.1W; +-5%	Rohm	MCR03 EZHJ 104	0662057A97
R664	6.8 Kohm; 0.1W; +-5%	Rohm	MCR03 EZHJ 682	0662057A69
R665	1 Mohm; 0.1W; +-5%	Rohm	MCR03 EZHJ 105	0662057B22
R666	68 Kohm; 0.1W; +-5%	Rohm	MCR03 EZHJ 683	0662057A93
R667	680 Kohm; 0.1W; +-5%	Rohm	MCR03 EZHJ 684	0662057B18
R668	1 Kohm; 0.1W; +-5%	Rohm	MCR03 EZHJ 102	0662057A49
R669	0 ohm; 0.1W; +-5%	Rohm	MCR03 EZHJ 000	0662057B47
R701	2.2 Kohm; 0.1W; +-5%	Rohm	MCR03 EZHJ 222	0662057A57
R702	1.5 Kohm; 0.1W; +-5%	Rohm	MCR03 EZHJ 152	0662057A53
R703	330 Kohm; 0.1W; +-5%	Rohm	MCR03 EZHJ 334	0662057B10
R704	47 Kohm; 0.1W; +-5%	Rohm	MCR03 EZHJ 473	0662057A89
R705	22 ohm; 0.1W; +-5%	Rohm	MCR03 EZHJ 220	0662057A09
R706	470 ohm; 0.1W; +-5%	Rohm	MCR03 EZHJ 471	0662057A41
R707	10 Kohm; 0.1W; +-5%	Rohm	MCR03 EZHJ 103	0662057A73
R708	2.2 Kohm; 0.1W; +-5%	Rohm	MCR03 EZHJ 222	0662057A57
R709	0.27 ohm; 0.125W; +-5%	Rohm	MCR10 EZHJ R27	0662057C02
R710	100 ohm; 0.1W; +-5%	Rohm	MCR03 EZHJ 101	0662057A25
R711	2.2 Kohm; 0.1W; +-5%	Rohm	MCR03 EZHJ 222	0662057A57
R712	1 Kohm; 0.1W; +-5%	Rohm	MCR03 EZHJ 102	0662057A49
R713	2.2 Kohm; 0.1W; +-5%	Rohm	MCR03 EZHJ 222	0662057A57
R714	2.2 Kohm; 0.1W; +-5%	Rohm	MCR03 EZHJ 222	0662057A57
R715	4.7 Kohm; 0.1W; +-5%	Rohm	MCR03 EZHJ 472	0662057A65
R716	0 ohm; 0.1W; +-5%	Rohm	MCR10 EZH J 000	0662057C01
R717	0 ohm; 0.1W; +-5%	Rohm	MCR10 EZH J 000	0662057C01
R913	10 Kohm; 0.1W; +-5%	Rohm	MCR03 EZHJ 103	0662057A73
R914	150 Kohm; 0.1W; +-5%	Rohm	MCR03 EZHJ 151	N/A
R928	151 Kohm; 0.1W; +-5%	Rohm	MCR03 EZHJ 151	N/A
R929	10 Kohm; 0.1W; +-5%	Rohm	MCR03 EZHJ 103	0662057A73
R930	100 Kohm; 0.1W; +-5%	Rohm	MCR03 EZHJ 104	0662057A97
R934	1 Kohm; 0.1W; +-5%	Rohm	MCR03 EZHJ 102	0662057A49
R935	4.7 Kohm; 0.1W; +-5%	Rohm	MCR03 EZHJ 472	0662057A65
RV601	10 Kohm; 0.1W; +-5%	Rohm	MVR22 HXBR N 103	N/A
RV602	10 Kohm; 0.1W; +-5%	Rohm	MVR22 HXBR N 103	N/A
SP701	Speaker	Orient sound	K028NA	N/A
SW201	Potentiometers	Tocos	TP76N17N A10Kohm 10SK	DSVR010008

Circuit Ref	Description	Vendor	Vendor Part Number	Motorola Equivalent Part Number
X301	Crystal	Nikko Denshi	TOP-B 14.4MHz RANK-2	DSXT181002
X501	Crystal	Nikko Denshi	TOP-B 44.645MHz +- 10ppm, +-4ppm	DSXT181006

**This Page Intentionally Left Blank**

---

## Glossary of Terms

Term	Definition
Active Scan State	The state when the radio is in Scan Mode, and when the radio is rapidly moving through the Scan List Member channels looking for eligible transmission activity.
Busy Channel Lockout (BCL)	If BCL is activated, the radio will check for channel activity before transmitting. If activity is detected, transmission is prohibited. For carrier squelch mode, radio will not transmit, if it is receiving carrier. For coded squelch mode, it will not transmit, if it is receiving carrier with different PL/DPL code.
Carrier	An electromagnetic signal that is transmitted on a selected frequency for the purpose of carrying voice or data transmissions along with it. Carrier can then be received by all radios listening on that frequency.
Carrier Squelch (CSQ)	When the carrier energy exceeds the carrier energy threshold, known as the Squelch Level, the radio unmutes.
CD	Compact Disk.
Channel	A single path separated by frequency or time divisions used for transmitting and/or receiving voice and/or data.
Channel Alias	Channel Aliases are radio-user descriptions for the radio's channels. Alphabets, numbers, spaces, "+", "-", and "/" can be used. Examples: EMT-001, 500, SECURITY.
Channel Bandwidth	The channel spacing when operating on the current channel.
Channel Enabled	When selected, the channel is enabled and accessible.
Coded Squelch	When the channel receives incoming message that contains the same PL or DPL code as its Rx PL/DPL code, the radio unmutes.
Codeplug	A solid-state chip inside a radio where the radio's personality data is stored.
Communications Port (COM Port)	A serial hardware interface connection at the back of a computer used to communicate with other hardware devices, such as radios, modems, and printers. Also known as a Serial Port. COM Ports are designated by slot positions such as Port1, Port2, Port3, Port4. When programming a radio, the computer is connected to the radio with a RIB cable via the COM port. The computer's CPS Com Port settings are independent of each other and apply to the Read and Write features.
CPS	Acronym for Customer Programming Software. Licensed Motorola software used to program two-way radios with a unique set of features.
CSQ	Carrier Squelch.
CTCSS	Acronym for <i>Continuous Tone Coded Squelch System</i> . A generic term for sub-audible tone/ code used to create communications groups. Also see <i>PL</i> .

---

<b>Term</b>	<b>Definition</b>
Digital Private Line (DPL)	DPL is a digital format transmitted along with the carrier. DPL allows for more use and privacy on a frequency. DPL is transmitted at a sub-audible (not able to be heard) frequency.
DPL	Digital Private-Line™
DTMF	Dual-Tone Multi-frequency. A Signaling System protocol widely used in the telephone industry. Two tones are transmitted simultaneously at different amplitudes for each keypad key press. A sequential series of Dual Tones makes a data word.
DTMF Tx Tone Duration	DTMF Tx Tone Duration is the amount of time that a DTMF tone is transmitted for a single digit. Once this Tx Tone Duration ends, the DTMF Tx Tone Interval begins, and vice-versa.
DTMF Tx Tone Interval	DTMF Tx Tone Interval is the amount of time that the radio waits between DTMF digits. Once Tx Tone Interval ends, the DTMF Tx Tone Duration begins, and vice-versa.
EEPROM	Electronically Erasable/Programmable Read-Only Memory: used by the radio to store its personality.
Firmware	Software, or a software/hardware combination of computer programs and data, with a fixed logic configuration stores in a read-only memory. Information cannot be altered or reprogrammed.
FGU	Frequency Generation Unit.
Frequency	(a) The location of the center of a channel of operation in the radio spectrum. Measured in Megahertz (MHz). (b) A computer speed. Measured in Megahertz (MHz).
Hard Pot	Hardware potentiometer for adjustment of parameter settings.
Home Channel	The channel where scan is started.
Landed Scan State	When the radio is in Scan Mode, and once Active Scan finds an eligible Scan List Member channel/call to receive or unmute to, the radio is then in Landed Scan State. Also, once both Transmit and Receive activity has ceased, and while the Scan Hang Timer is counting down, the radio is still in Landed Scan Mode.
Latest Codeplug Version	The most recent version number of codeplug information that was loaded into the radio. This is stored in the radio's codeplug.
LCD	Liquid Crystal Display: a module used to display the radio's current operating channel info or status message.
Long Press Function	Function that is invoked if the button is pressed and released after one second.
Lower Scan Frequency	The lower limit that VFO will scan.
Maximum Frequency	The highest frequency setting at which the radio is allowed to operate. The radio's frequency range is defined as being between, or equal to, the Minimum and Maximum frequencies. This information is stored in the radio's codeplug.



<b>Term</b>	<b>Definition</b>
Minimum Frequency	The lowest frequency setting at which the radio is allowed to operate. The radio's frequency range is defined as being between, or equal to, the Minimum and Maximum frequencies. This information is stored in the radio's codeplug.
Model Number	The model number identifies the type of radio. This information is stored in the radio's codeplug.
Normal Scan	For Normal Scan, the radio assigns equal priority to all members in the Scan List selected for the current channel. When the radio is scanning a Scan List (Active Scan), all scan list members (including the Home Channel) will be allocated equal time to be scanned. For example, if the Home Channel is H1, and the Scan List Members are Nn, then the scanning sequence is: N1, N2, N3, ..., H1, N1, N2, ..., etc.
Offset Frequency	If Tx Offset is set to Positive, this frequency will be added to the VFO Rx Frequency when radio is transmitting. It will be subtracted from the VFO Rx Frequency if Tx Offset is set to Negative.
Original Codeplug Version	The first version number of codeplug information that was loaded into the radio. This is stored in the radio's codeplug.
PC Board	Printed Circuit Board.
Phone Access Code	The 16 digit Access Code for establishing connection to a telephone line and subsequent dial tone.
Phone De-access Code	The 16 digit De-access Code for disconnecting from a phone call.
Phone List	A list of phone numbers (up to nine phone numbers) that can be preprogrammed into the radios. Each phone number can contain 16 characters made up by alphabets (A, B, C, D), numbers (0-9), spaces, "#" and "*".
PL	Private-Line® tone squelch: a continuous sub-audible tone that is transmitted along with the carrier.
PLL	Phase-Locked Loop: a circuit in which an oscillator is kept in phase with a reference, usually after passing through a frequency divider.
Preamble	Selects the amount of time between PTT button press and the first digit of ID transmission. This time allows the receiving radio to stabilize before receiving data.
Priority Scan	For Priority Scan, the radio assigns the highest priority to the first member in the Scan List selected for the current channel. When the radio is scanning a Scan List (Active Scan), 50% of the scans are targeted at the Priority #1 Member channel. For example, if the Priority #1 Member is P1, and the non-priority Scan List Members are Nn, then the scanning sequence is: P1, N1, P1, N2, P1, N3, P1, N4, P1, N5, etc.

Term	Definition
Priority #1 Scan List Member	<p>The first member in the current Scan List. When the radio is scanning a Scan List (Active Scan), 50% of the scans are targeted at the Priority #1 Member channel. Example: If the Priority #1 Member is P1, and the non-priority Scan List Members are Nn, then the scanning sequence is: P1 N1, P1 N2, P1 N3, P1 N4, P1 N5, etc.</p> <p><b>Note:</b> When the radio's speaker is unmuted to a non-priority call (Landed Scan mode), the radio continues to mute at a specific time interval (the Scan Interval Time), and scan for transmission activity on the Priority #1 Member channel. If the radio discovers a valid Priority #1 transmission, it drops the current transmission, and unmutes to the Priority #1 call. Priority Scan has to be enabled (per channel) for this feature to function.</p>
Prime Channel Return Hang Time	The amount of time that the radio will stay idle in another channel before reverting back to the Prime Channel.
Private Line (PL)	A sub-audible tone/code used to create unique/private communication groups while operating in Conventional Dispatch mode. A generic term for Tone Private Line (TPL), or Digital Private Line (DPL).
Program	The transfer of CPS information from the computer's temporary memory (RAM) to the radio.
PTT	Push-To-Talk: the switch located on the left side of the radio which, when pressed, causes the radio to transmit.
PTT ID Select	If PTT ID is activated for the channel, then PTT ID will be sent following the PTT ID Transmission Type.
PTT Short Sidetone	PTT Short Sidetone causes the radio to sound one short alert tone, after the PTT button is pressed, and immediately following the ID being transmitted. The purpose is to indicate to the radio-user when voice may be initiated.
Random Access Memory (RAM)	A temporary storage space used by a computer to operate a software program currently running. Anything stored in RAM is lost when the computer is turned off.
Registers	Short-term data-storage circuits within the microcontroller.
Repeater	Remote transmit/receive facility that retransmits received signals to improve communications coverage.
RESET	Reset line: an input to the microcontroller that restarts execution.
RF PA	Radio Frequency Power Amplifier.
Radio Interface Box (RIB)	Used to connect a personal computer to a radio for the purpose of communication between the two. The RIB consists of level-shifting circuits that convert from the standard RS-232 voltage levels of the computer asynchronous serial interface (COM Port) to the single-ended voltage levels present on the Serial Bus contacts of the radio's connector. The RIB must have an appropriate RIB-to-radio and RIB-to-computer Radio Interface Cable for communication and radio programming to occur.
Receive Frequency	A designated frequency used when receiving carrier for the current channel.

<b>Term</b>	<b>Definition</b>
Reverse Burst / Turn Off Code	Causes a Tone Private Line (TPL) or Digital Private Line (DPL) code to be transmitted at the end of a transmission - once PTT is released, and while operating on the current channel. This sub-audible tone causes the receiving radio to mute its speaker before loss of a carrier is detected. Muting the speaker eliminates unwanted noise (squelch tail) during loss of carrier detection.
ROM	Read Only Memory.
RSSI	Received Signal-Strength Indicator: a dc voltage proportional to the received RF signal strength.
RPT/TA	Repeater/Talk-Around.
Rx DPL Code	The specific code accepted when receiving Digital Private Line (DPL) encoding, while operating on the current channel.
Rx DPL Invert	Setting Rx DPL Invert causes Digital Private Line (DPL) signals to be inverted when they are received by the radio, while operating on the current channel. Inverted coding allows for more traffic/usage on frequencies.
Rx TPL Frequency	A designated frequency used when receiving Tone Private Line (TPL), while operating on the current channel. This frequency can directly correlate to the Rx TPL Code field; however, non standard code frequencies may also be selected.
Scan List	The Scan List determines which channels the radio scans, when operating in the Scan Mode, on the current channel.
Scan List Member	The Scan List allows you to select the grouping of channels that make up the current Scan List Member channels. This grouping of Scan List Member channels can then be scanned for transmission activity - one at a time, when the radio is in Scan Mode. A Scan List can have a maximum of 16 Scan List Members. Scan List Member scanning priority is definable. A Scan List can be assigned to a channel. Three Scan Lists are available. A Scan List can be assigned to more than one channel.
Scan Mode	When the radio is in one of the two Scan States: Active Scan and Landed Scan. This mode is initiated when the programmable SCAN button is pressed.
Scan Type	There are two types of scanning available on the current Conventional Personality: Normal Scan or Priority Scan.
Serial Number	Each radio has its own unique serial number. This information is stored in the radio's codeplug.
Short Press Function	Function that is invoked if the button is pressed and released within one second.
Softpot	Software Potentiometer: a computer-adjustable electronic attenuator.
Software	Computer programs, procedures, rules, documentation, and data pertaining to the operation of a system.
Squelch	Muting of audio circuits when received signal levels fall below a pre-determined value.

Term	Definition
Squelch Level	The amount of carrier energy required to unmute the radio's speaker upon satisfying the selected Carrier Squelch threshold. Low level allows more transmissions with less clarity to unmute the radio's speaker. High level increases the squelch threshold causing a stronger carrier signal to be required before the radio's speaker will unmute. This helps to reduce unwanted noise.
Tone Private Line (TPL)	Transmitted when the receiving radio is to only receive calls from radios with specific TPL codes, this creates communications groups while operating in Conventional Dispatch mode. TPL allows for more use and privacy on a frequency. TPL is transmitted at a sub-audible (not able to be heard) frequency. Also known as CTCSS.
TOT	Time-Out Timer: a timer that limits the length of a transmission.
TPL	Tone Private-line.
Tx DPL Code	The Digital Private Line (DPL) code that transmits while operating on the current channel.
Tx DPL Invert	Setting Tx DPL Invert causes Digital Private Line (DPL) signals to be inverted before they are transmitted from the radio, while operating on the current channel. Inverted coding allows for more traffic/usage on frequencies.
Tx Frequency	A designated frequency used when transmitting carrier for the current channel.
Tx Offset	The offset that will be added to the VFO Rx Frequency when radio transmits in VFO mode. Available options are: None (transmits using Rx Frequency), Pos (transmits using Rx Frequency + Offset Frequency), Neg (transmits using Rx Frequency - Offset Frequency), User (transmits using the User Defined Tx Frequency).
Tx Power	The transmit power level while operating on the current channel. <b>High:</b> Used when a stronger signal is needed to extend transmission distances. <b>Low:</b> Used when communicating in close proximity, and to keep the radio from transmitting into other geographical groups operating on the same frequency. <b>Economy Low:</b> Used when communicating distance is close, e.g., within the same warehouse, stadium, etc.
Tx TPL Frequency	A designated frequency used to transmit Tone Private Line (TPL) encoding, while operating on the current channel. This frequency can directly correlate to the Tx TPL Code field; however, non standard code frequencies may also be selected.
μC	Microcontroller.
UHF	Ultra High Frequency.
Unmuting	A radio unmutes, when it opens its speaker to receive audio.
μP	Microprocessor.
Upper Scan Frequency	The upper limit that VFO will scan.

---

<b>Term</b>	<b>Definition</b>
User Defined PL Frequency	You can customize up to three non standard PL frequencies to provide more choices for PL.
VCO	Voltage-Controlled Oscillator: an oscillator whereby the frequency of oscillation can be varied by changing a control voltage.
VFO	Variable Frequency Operation. The radio user chooses frequencies instead of preprogrammed channels to operate the radio.
VFO Scan	Radio scans the preprogrammed frequency range defined by VFO Upper Scan Frequency and Lower Scan Frequency in the increment defined by Frequency Step Size.
VHF	Very High Frequency.
VSWR	Voltage Standing Wave Ratio.

**This Page Intentionally Left Blank**





Motorola, Inc.  
8000 West Sunrise Boulevard  
Ft. Lauderdale, FL 33322

MOTOROLA and the Stylized M Logo are registered in the  
U.S. Patent and Trademark Office. All other product or service  
names are the property of their respective owners.  
© Motorola, Inc. 2002.  
All rights reserved. Printed in U.S.A.



**99R85452E01-O**